

KORLOY



Außendrehhalter & Bohrstangen



Luft- und Raumfahrt



Automotive



Medizintechnik

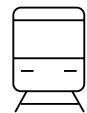

Eisenbahn



Drehen

KORLOY Drehwerkzeuge decken den gesamten ISO-Bereich ab. Sie bieten Lösungen für nahezu alle Anwendungsbereiche mit höchsten Ansprüchen an Qualität und Präzision.



INHALT

Spanbrecher

- 04 Übersicht der Wendeschneidplatten

Außendrehhalter

- 04 Codesystem (ISO)
- 05 Anweisungen zur Montage
- 06 Index
- 09 Merkmale Doppelklemmsystem /
Neues Kniehebelsystem
- 10 Doppelklemmsystem
- 16 Kniehebelsystem
- 26 Keilklemmsystem
- 27 Klemmsystem
- 31 Mehrfachklemmsystem
- 42 Schraubsystem
- 52 Halter für keramische
Wendeschneidplatten

Drehhalter mit Hochdruckkühlung

- 55 KHP Halter mit Hochdruckkühlung

Bohrstangen





- 60 Codesystem (ISO)
- 61 Anweisungen zur Montage
- 62 Index
- 64 Doppelklemmsystem
- 69 Kniehebelsystem
- 72 Klemmsystem
- 74 Mehrfachklemmsystem
- 79 Schraubsystem
- 88 Compact Mini
- 90 Bohrstange mit Hartmetallschaft



KORLOY



Sortenübersicht

Anwendung	Sorten	Spanbrecher
P Stahl	NC3215, NC3225	
M Rostfreier Stahl	NC9115, NC9125, NC9135	
K Gusseisen	NC6310, NC6315	
S HRSA	UNC805, PC8110	

P Zum Drehen von Stahl NC3215 / NC3225

- CVD beschichtete Hochleistungswendeschneidplatte zum Drehen von geschmiedetem Stahl- und Lagerstahl
- Erhöhte Produktivität durch kontrollierten Spanbruch bei verschiedenen Bearbeitungen
- Reduzierte Schnittlast ermöglicht stabile Standzeit bei hohen Geschwindigkeiten und hohen Vorschüben



Merkmale des LP Spanbrechers

Vorderes "Dots"-Paar

- Stabilere Spanleitung bei hohen Vorschüben
- Hervorragende Spankontrolle beim Kopierdrehen
- Geringere Schneidkräfte bei großen Schnitttiefen

Verschiedene Spanwinkel

- Weniger Kerbverschleiß
- Verhindert Ausbrüche der Nebenschneide

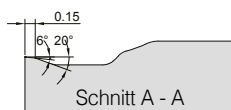
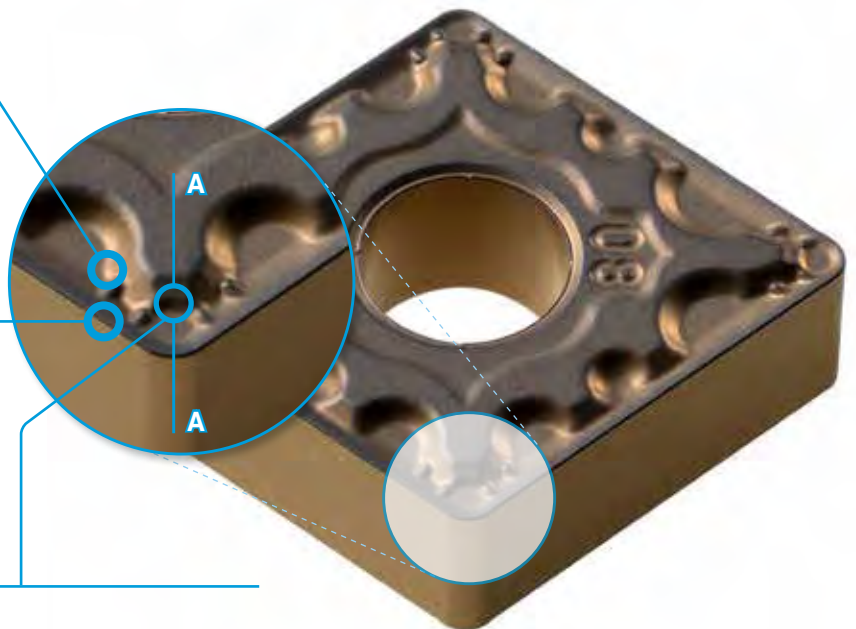

Flachbereich

- Größerer Spanleitbereich zur besseren Spanabfuhr
- Verringerte Schneidkräfte und größere Kontaktfläche zum Span



Merkmale des MP Spanbrechers

Vorderes "Dots"-Paar

- Stabilere Spanleitung bei hohen Vorschüben
- Hervorragende Spankontrolle beim Kopierdrehen
- Geringere Schneidkräfte bei großen Schnitttiefen

Verschiedene Spanwinkel

- Weniger Kerbverschleiß
- Verhindert Ausbrüche der Nebenschneide
- Höhere Beständigkeit bei hohen Schnitttiefen und unterbrochenem Schnitt

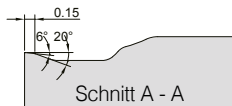
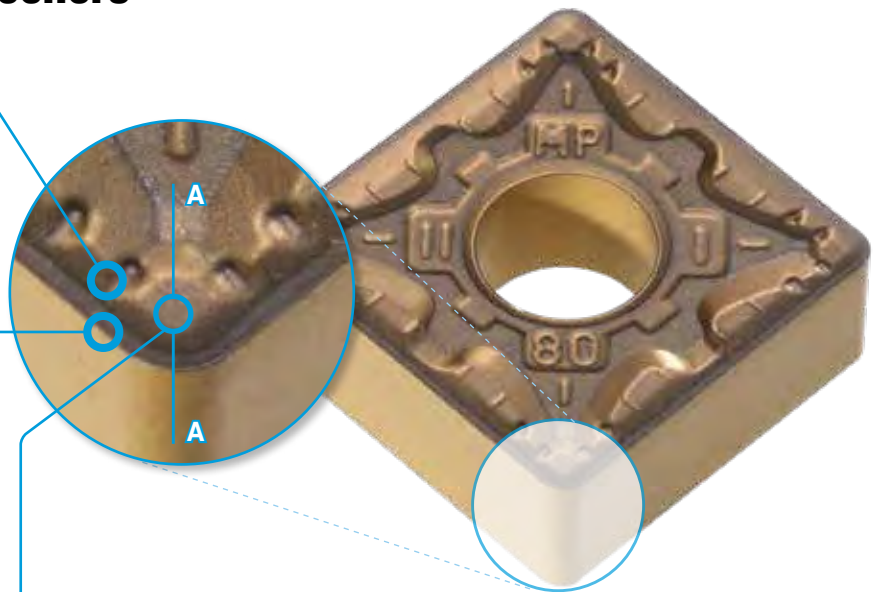

Flachbereich

- Größerer Spanleitbereich zur besseren Spanabfuhr
- Verringerte Schneidkräfte und größere Kontaktfläche zum Span

K Zum Drehen von Gusseisen NC6315

- CVD-beschichtete Wendeschneidplatten vermindern den Verschleiß an den Span- und Freiflächen
- Weniger Abschälungen und weniger Gratbildung
- Verbesserte Drehbearbeitung von Gusseisen bei hoher Schnittgeschwindigkeit, hohen Vorschüben und unterbrochenem Schnitt

Merkmale des MM Spanbrechers

Variable Fläche

- Ausgezeichnete Spankontrolle und scharfe Schneide bei geringen Schnitttiefen
- Verzögert Kolkverschleiß
- Verhindert plastische Verformung

Duale Fläche

- Ausgeglichenheit zwischen Anforderungen von scharfen und zähen Schneidkanten
- Scharfe Schneidkante für Hochgeschwindigkeitsbearbeitung
- Verhindert Abschälung bei unterbrochener Bearbeitung

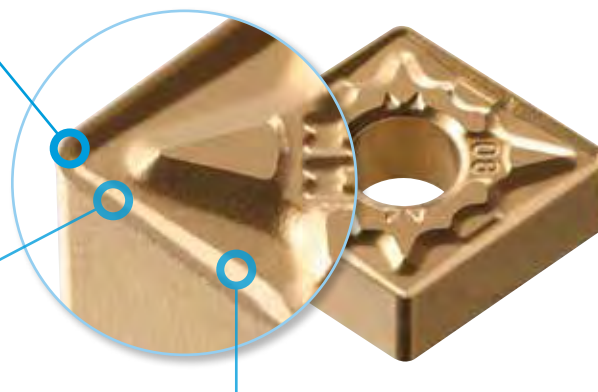

Breite Spantasche

- Stabile Spanausbringung bei hohen Geschwindigkeiten /-Vorschüben
- Verbesserte Oberflächengüte durch Reduzierung von Werkstückriefen, verursacht durch kaltverfestigte Späne bei großen Schnitttiefen
- Verhindert Aufbauschneide



Merkmale des RM Spanbrechers

Variable Fläche

- Ausgezeichnete Spankontrolle und scharfe Schneide bei geringen Schnitttiefen
- Verzögert Kolkverschleiß
- Verhindert plastische Verformung

Breite Fläche & flacher Frontwinkel

- Scharfe Schneidkanten und breite Flächen reduzieren Schnittlast
- Reduzierte Grate
- Verteilte Schnittlast ermöglicht höhere Zähigkeit

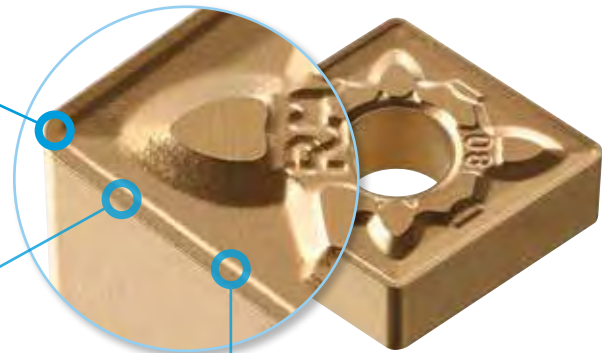

Stufenförmiges Design

- Stufenförmiges Design erleichtert die Spanausbringung
- Gute Spanausbringung verhindert plastische Verformung

M CVD Sorten zum Drehen rostfreier Stähle **NC9115 / NC9125 / NC9135**

- Verlängerte Standzeit bei hohen Geschwindigkeiten, Vorschüben und Schnitttiefen
- Eine große Sortenauswahl für die meisten Werkstückgrößen und Ausführungen, einschließlich stark unterbrochenem Schnitt
- Verhindert Aufbauschneidenbildung, Kerkverschleiß, plastische Verformung und Gratentstehung





VP2 Spanbrecher

- Für die Mittlere bis Schlichtbearbeitung
- Hoch positive Spanfläche und Seitenspanwinkel, guter Spanbruch bei verschiedenen Schnitttiefen vereinfacht die Bearbeitung
- Empfohlenen Schnittwerte: $f_n(\text{mm/U}) = 0,1 - 0,4$ / $a_p(\text{mm}) = 0,5 - 4,5$

Merkmale

Scharfe Schneide und breite Spantaschen

Produktivität erhöht, ideal für die mittlere Bearbeitung bis Schlichten.

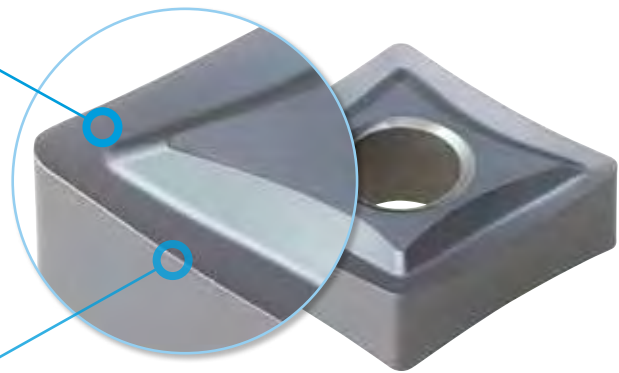
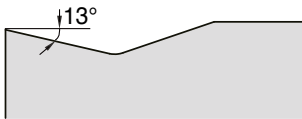

Hoch positive Spanfläche

Scharfe Schneidkante und verringern die Hitzeentwicklung bei der Bearbeitung.

VP4 Spanbrecher

- Erste Wahl für die Bearbeitung von Inconel, mit hoher Beständigkeit und bei hohen Temperaturen
- Hohe Prozesssicherheit durch verstärkte Schneiden und breite Spantaschen

Merkmale

Spanwinkel mit hochfester Schneide

Verstärkte Schneide verhindert Kerbverschleiß bei der Schruppbearbeitung.
Verhindert das Absplintern bei unterbrochenem Schnitt.

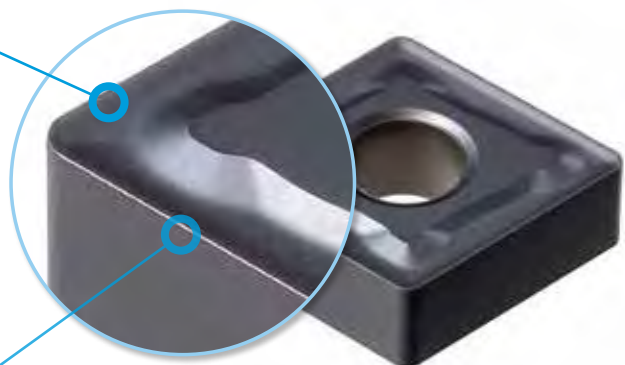
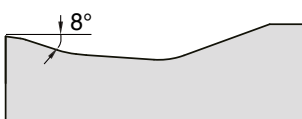

Große Spantaschen

Reduzieren die Schnittlasten und verbessern die Stabilität auch bei hoher Schrupptiefe.



Codesystem (ISO) für Außendrehhalter

P S K N R 25 25 - M 12

- 1
Spannsystem
- 2
Wendeschneidplattenform
- 3
Einstellwinkel
- 4
Freiwinkel
- 5
Werkzeugrichtung
- 6
Schafthöhe
- 7
Schafthbreite
- 8
Werkzeuglänge
- 9
Schneidkantenlänge

1 Spannsystem

P S K N R 25 25 - M 12

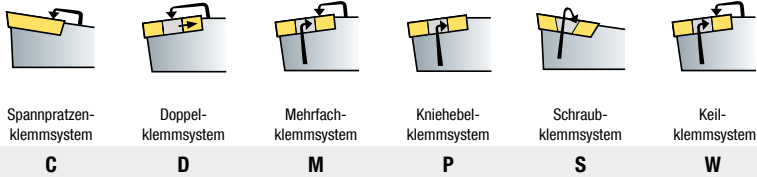

C D M P S W

2 Wendeschneidplattenform

P S K N R 25 25 - M 12

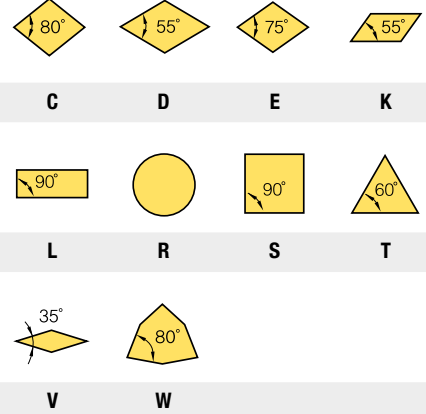

C D E K

L R S T

V W

3 Einstellwinkel

P S K N R 25 25 - M 12

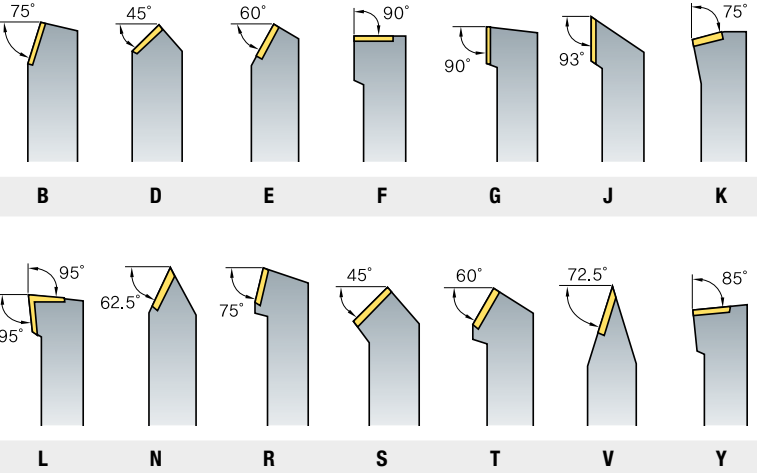

B D E F G J K

L N R S T V Y

4 Freiwinkel

P S K N R 25 25 - M 12

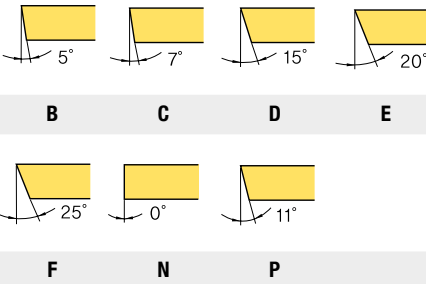

B C D E

F N P

5 Werkzeugrichtung

P S K N R 25 25 - M 12

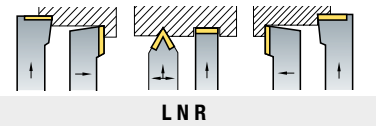

L N R

6 Schafthöhe

P S K N R 25 25 - M 12

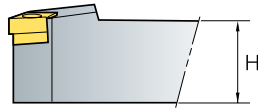

H

7 Schafthbreite

P S K N R 25 25 - M 12

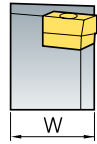

W

8 Werkzeuglänge

P S K N R 25 25 - M 12

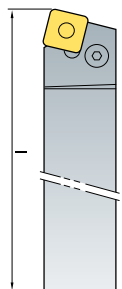

A - 32	H - 100	Q - 180	X-Spezial Artikel
B - 40	J - 110	R - 200	
C - 50	K - 125	S - 250	
D - 60	L - 140	T - 300	
E - 70	M - 150	U - 350	
F - 80	N - 160	V - 400	
G - 90	P - 170	W - 450	

9 Schneidkantenlänge

P S K N R 25 25 - M 12

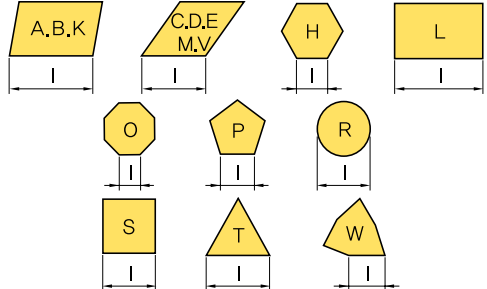



Montage von Außendrehhaltern

Doppelklemmsystem (D)

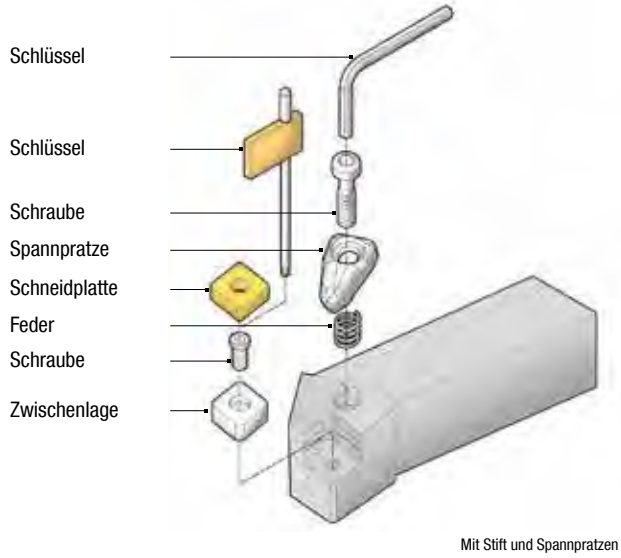

Kniehebelsystem (P)

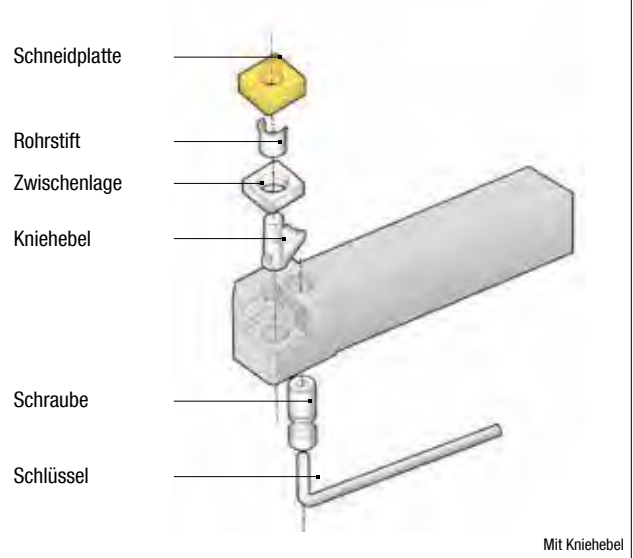

Keilklemmsystem (W)

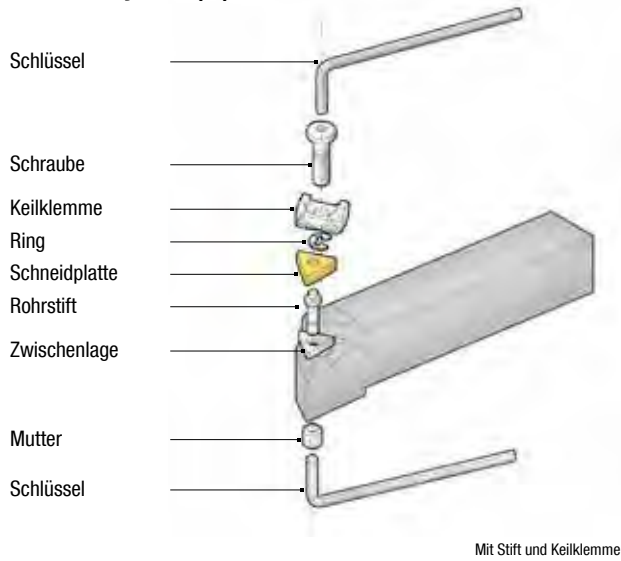

Spannpratzenklemmsystem (C)

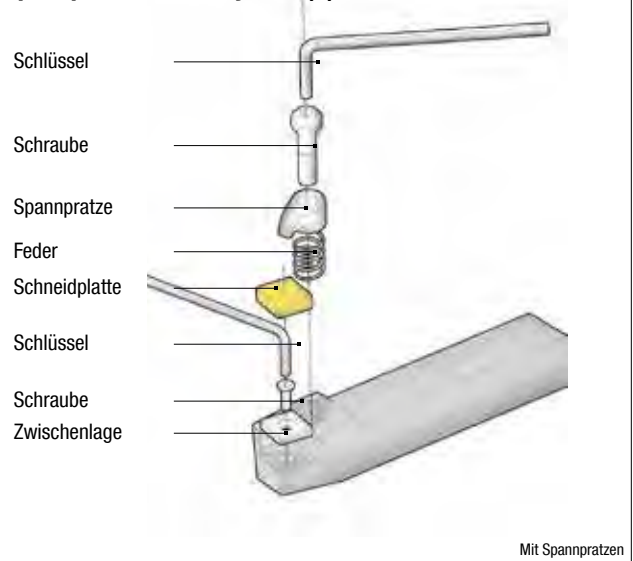

Mehrfachklemmsystem (M)

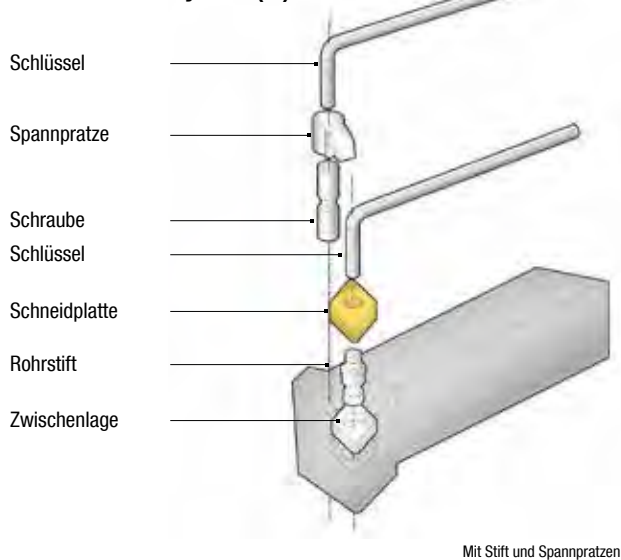

Schraubklemmsystem (S)

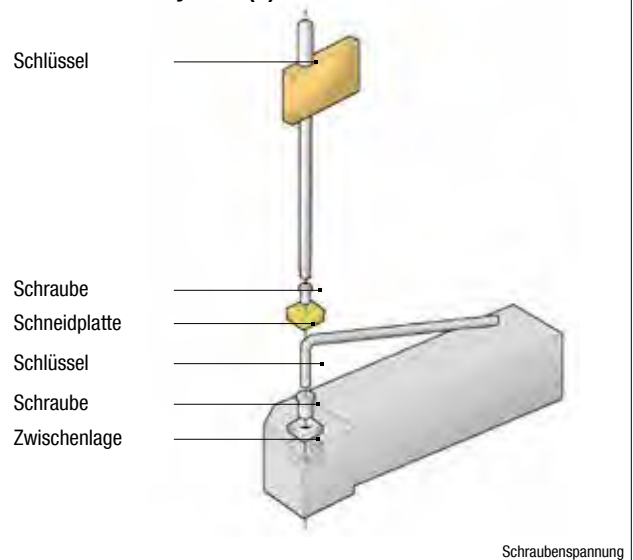



Doppelklemmsystem

Schnittform										
Bezeichnung	DCBNR/L	DCKNR/L	DCLNR/L	DDJNR/L	DSBNR/L	DSDNN	DSKNR/L	DSSNR/L	DTFNR/L	DTGNR/L
Anstellwinkel	75°	75°	95°	93°	75°	45°	75°	45°	90°	90°
Seite	9	9	10	10	11	11	12	12	13	13
Drehen	•		•	•	•	•		•		•
Kopieren				•						
Plandrehen		•	•				•	•	•	
Anfasen										
Rückwärtsdrehen			•	•						

Schnittform										
Bezeichnung	DTJNR/L	DVJNR/L	DVVNN	DWLNR/L						
Anstellwinkel	93°	93°	72,5°	95°						
Seite	13	14	14	14						
Drehen	•	•	•	•						
Kopieren		•	•	•						
Plandrehen				•						
Anfasen										
Rückwärtsdrehen		•		•						

Kniehebelsystem / Neues Kniehebelsystem

Schnittform										
Bezeichnung	PCBNR/L	PCKNR/L	PCLNR/L	PDJNR/L	PDNNR/L	PDNNN	PRDCN	PRGCR/L	PSBNR/L	PSDNN
Anstellwinkel	75°	75°	95°	93°	62,5°		-	-	75°	45°
Seite	15	15	16	17	17	18	18	18	19	20
Drehen	•	•	•	•	•		•	•	•	•
Kopieren				•	•		•	•		
Plandrehen			•							
Anfasen										
Rückwärtsdrehen		•	•							

Schnittform										
Bezeichnung	PSKNR/L	PSSNR/L	PTFNR/L	PTGNR/L	PTTNR/L	PWLNR/L				
Anstellwinkel	75°	45°	90°	90°	60°	95°				
Seite	21	22	22	23	23	24				
Drehen		•		•	•	•				
Kopieren										
Plandrehen	•	•	•			•				
Anfasen					•					
Rückwärtsdrehen						•				



Keilklemmsystem

Schnittform									
Bezeichnung	WTENN	WTJNR/L	WTXNR/L	WWLNR/L					
Anstellwinkel	60°	93°	105°	95°					
Seite	25	25	25	26					
Drehen	•	•	•	•					
Kopieren	•	•	•	•					
Plandrehen									
Anfasen									
Rückwärtsdrehen		•	•	•					

Spannpratzenklemmsystem

Schnittform									
Bezeichnung	CKJNR/L	CKNNR/L	CSDPN	CSKPR/L	CTFPR/L	CTGPR/L			
Anstellwinkel	93°	62,5°	45°	75°	90°	90°			
Seite	27	27	28	28	28	29			
Drehen	•	•	•			•			
Kopieren	•	•							
Plandrehen				•	•				
Anfasen									
Rückwärtsdrehen	•								

Mehrfachklemmsystem

Schnittform										
Bezeichnung	MCKNR/L	MCLNR/L	MCMNN	MCRNR/L	MDJNR/L	MDNNN	MDQNR/L	MSBNR/L	MSDNN	MSKNR/L
Anstellwinkel	75°	95°	50°	75°	93°	62,5°	107,5°	75°	45°	75°
Seite	30	30	31	31	32	32	33	33	34	34
Drehen		•	•	•	•	•	•	•	•	
Kopieren					•	•	•			
Plandrehen	•	•								•
Anfasen										
Rückwärtsdrehen		•			•		•			

Schnittform										
Bezeichnung	MSRRN/L	MSSNR/L	MTENN	MTFNR/L	MTGNR/L	MTJNR/L	MVJNR/L	MVQNR/L	MVVNN	MWLNR/L
Anstellwinkel	75°	45°	60°	90°	90°	93°	93°	117,5°	72,5°	95°
Seite	36	36	37	37	38	38	38	38	39	39
Drehen	•	•	•		•	•	•	•	•	•
Kopieren			•			•	•	•	•	
Plandrehen		•		•		•				•
Anfasen										
Rückwärtsdrehen						•	•	•		•



Schraubklemmsystem

Schnittform										
Bezeichnung	SCACR/L	SCLCR/L	SDACR/L	SDJCR/L	SDNCN	SRDCN	SRGCR/L	SSBCR/L	SSDCN	SSKCR/L
Anstellwinkel	90°	95°	90°	93°	62,5°	-	-	75°	45°	75°
Seite	40	40	41	41	42	42	43	43	44	44
Drehen	•	•	•	•	•	•	•	•	•	
Kopieren			•	•	•	•	•			
Plandrehen		•								•
Anfasen										
Rückwärtsdrehen		•		•						

Schnittform										
Bezeichnung	SSSCR/L	STACR/L	STFCR/L	STGCR/L	STTCR/L	SVABR/L	SVHBR/L	SVJBR/L	SVJCR/L	SVVBN
Anstellwinkel	45°	90°	90°	90°	60°	90°	107,5°	93°	93°	72,5°
Seite	44	45	45	46	46	47	47	48	48	49
Drehen	•	•		•	•	•	•	•	•	•
Kopieren						•	•	•	•	•
Plandrehen	•		•							
Anfasen										
Rückwärtsdrehen						•	•	•	•	

Schnittform										
Bezeichnung	SVVCN	SWACR/L								
Anstellwinkel	72,5°	90°								
Seite	49	50								
Drehen	•	•								
Kopieren	•									
Plandrehen										
Anfasen										
Rückwärtsdrehen										

Halter für keramische Wendeschneidplatten

Schnittform										
Bezeichnung	CCNLR/L	CRDNN	CRGCR/L	CSDNN	CSKNR/L	CTFNR/L	CTGCR/L			
Anstellwinkel	95°	-	-	45°	75°	90°	90°			
Seite	B150	B150	B150	B151	B151	B151	B152			
Drehen	•	•	•	•			•			
Kopieren			•							
Plandrehen	•				•	•				
Anfasen										
Rückwärtsdrehen	•									



Doppelklemmsystem

Stabile Klemmung mit Doppelklemmsystem

Merkmale

- Einfaches und leistungsstarkes Klemmsystem mit nur einer Klemmschraube
- Das leistungsstarke Doppelklemmsystem (oben und innen) eignet sich für den Einsatz unter sehr schweren Zerspanungsbedingungen
- Der Halter zeichnet sich dank der speziellen Konstruktion im hinteren Teil der Klemme durch eine hohe Präzision aus
- Kompaktes und optimiertes Design zur Vermeidung von Störungen durch Späne in Verbindung mit einer leistungsstarken Klemme

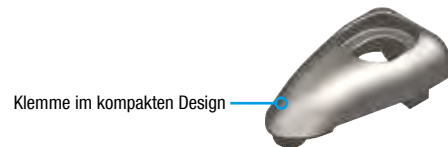
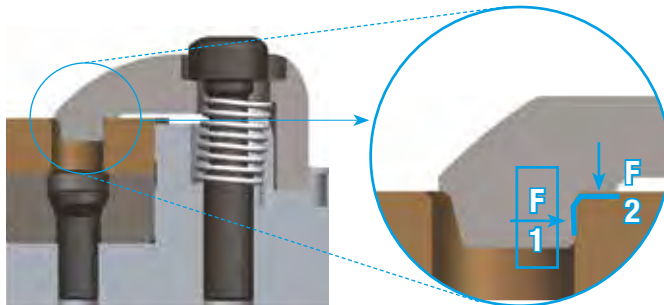
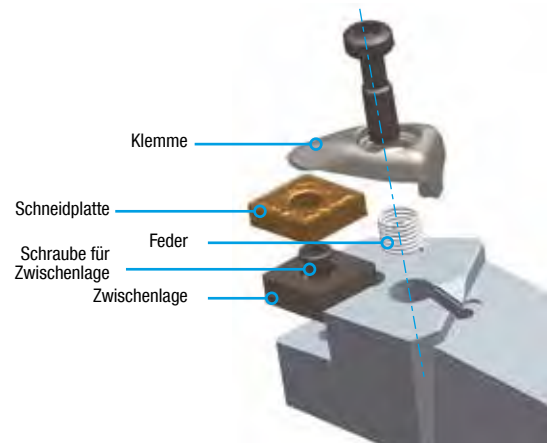

Neues Kniehebelsystem

Verbesserte Haltbarkeit und Spannkraft im Vergleich zu herkömmlichen Kniehebelsystemen

Merkmale

- Der Halter zeichnet sich dank der speziellen Konstruktion des verbesserten Hebelplattensitzes durch eine hohe Präzision aus
- Die Haltbarkeit der Teile wurde verbessert
- Überragende Standzeiten durch das leistungsstarke Klemmsystem und die optimierte Konstruktion
- Entsprechendes Zubehör auf dem Schaft des jeweiligen Halters vermerkt

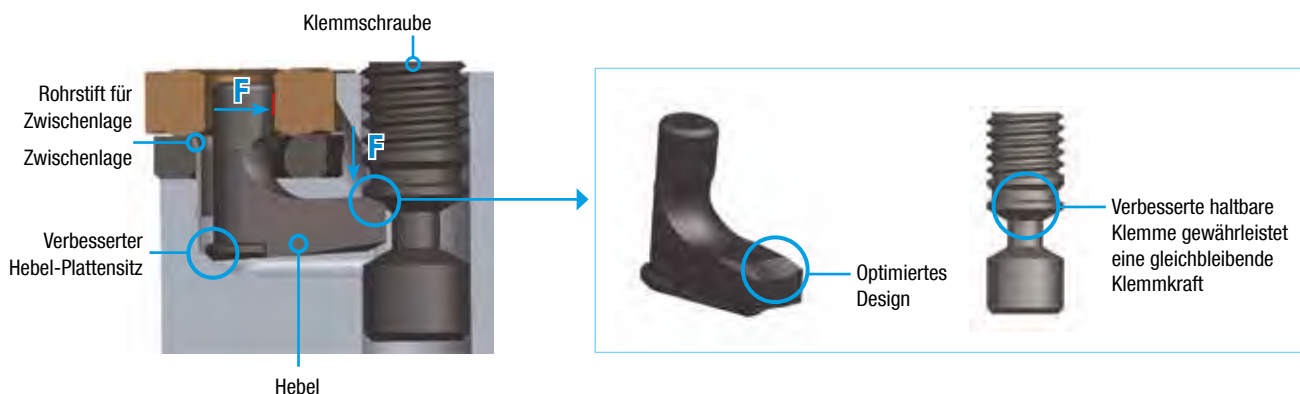



DCBNR/L

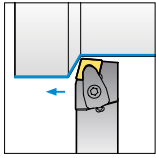

Rechtsausführung
75°

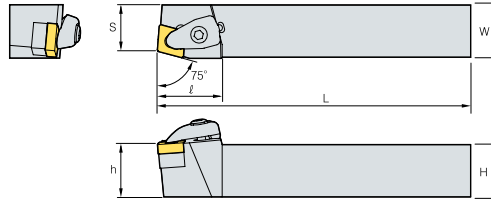

WSP



CN_

(mm)

Bezeichnung	H	W	L	S	h	ℓ	WSP	Feder	Klemme	Klemmschraube	Lagenschraube	Schlüssel	Zwischenlage	
DCBNR/L	2020-K12	20	20	125	17	20	31	CN_1204_	SPR0714	CVH4	CHX0518	FTKA0410	HW30P	SC44V
	2525-M12	25	25	150	22	25	31		SPR0714	CVH4	CHX0518	FTKA0410	HW30P	SC44V
	2525-M16	25	25	150	22	25	36	CN_1606_	SPR0811	CVH5	CHX0622	FTNA0511	HW40L	SC54V
	3225-P12	32	25	170	22	32	31	CN_1204_	SPR0714	CVH4	CHX0518	FTKA0410	HW30P	SC44V
	3232-P16	32	32	170	27	32	36	CN_1606_	SPR0811	CVH5	CHX0622	FTNA0511	HW40L	SC54V
	3232-P19	32	32	170	27	32	40	CN_1906_	SPR0811	CVH6	CHX0622	FTNA0511	HW40L	SC63V
	4040-S19	40	40	250	35	40	40		SPR0811	CVH6	CHX0622	FTNA0511	HW40L	SC63V
	4040-S25	40	40	250	35	40	47	CN_2507_	SPR1018	CVH8	CHX0835	FTKA0612	HW50L	SC83V

DCKNR/L

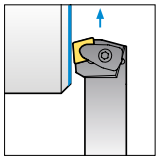

Rechtsausführung
75°

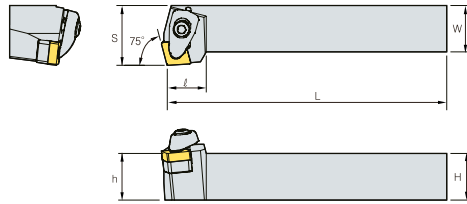

WSP



CN_

(mm)

Bezeichnung	H	W	L	S	h	ℓ	WSP	Feder	Klemme	Klemmschraube	Lagenschraube	Schlüssel	Zwischenlage	
DCKNR/L	2020-K12	20	20	125	25	20	21	CN_1204_	SPR0714	CVH4	CHX0518	FTKA0410	HW30P	SC44V
	2525-M12	25	25	150	32	25	21		SPR0714	CVH4	CHX0518	FTKA0410	HW30P	SC44V
	3225-P12	32	25	170	32	32	21		SPR0714	CVH4	CHX0518	FTKA0410	HW30P	SC44V
	3232-P16	32	32	170	40	32	26	CN_1606_	SPR0811	CVH5	CHX0622	FTNA0511	HW40L	SC54V
	4040-S16	40	40	250	50	40	26		SPR0811	CVH5	CHX0622	FTNA0511	HW40L	SC54V
	4040-S19	40	40	250	50	40	26	CN_1906_	SPR0811	CVH6	CHX0622	FTNA0511	HW40L	SC63V



DCLNR/L

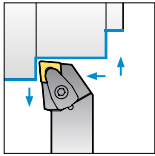

Rechtsausführung
95°

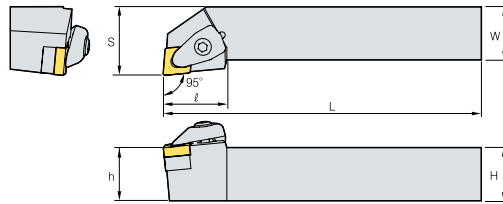

WSP



CN_

(mm)

Bezeichnung	H	W	L	S	h	ℓ	WSP	Feder	Klemme	Klemmschraube	Lagenschraube	Schlüssel	Zwischenlage
DCLNR/L 2020-K09	20	20	125	25	20	24,5	CN_0903_	SPR0510	CVH3	CHX0415	FTKA0307	HW25P	SC32V
2020-K12	20	20	125	25	20	30	CN_1204_	SPR0714	CVH4	CHX0518	FTKA0410	HW30P	SC44V
2525-M09	25	25	150	32	25	24,5	CN_0903_	SPR0510	CVH3	CHX0415	FTKA0307	HW25P	SC32V
2525-M12	25	25	150	32	25	30	CN_1204_	SPR0714	CVH4	CHX0518	FTKA0410	HW30P	SC44V
2525-M16	25	25	150	32	25	36	CN_1606_	SPR0811	CVH5	CHX0622	FTNA0511	HW40L	SC54V
2525-M19	25	25	150	32	25	40	CN_1906_	SPR0811	CVH6	CHX0622	FTNA0511	HW40L	SC63V
3225-P12	32	25	170	32	32	30	CN_1204_	SPR0714	CVH4	CHX0518	FTKA0410	HW30P	SC44V
3225-P16	32	25	170	32	32	36	CN_1606_	SPR0811	CVH5	CHX0622	FTNA0511	HW40L	SC54V
3225-P19	32	25	170	32	32	40	CN_1906_	SPR0811	CVH6	CHX0622	FTNA0511	HW40L	SC63V
3232-P12	32	32	170	40	32	30	CN_1204_	SPR0714	CVH4	CHX0518	FTKA0410	HW30P	SC44V
3232-P16	32	32	170	40	32	36	CN_1606_	SPR0811	CVH5	CHX0622	FTNA0511	HW40L	SC54V
3232-P19	32	32	170	40	32	40	CN_1906_	SPR0811	CVH6	CHX0622	FTNA0511	HW40L	SC63V
4040-S19	40	40	250	50	40	40		SPR0811	CVH6	CHX0622	FTNA0511	HW40L	SC63V
4040-S25	40	40	250	50	40	47	CN_2507_	SPR1018	CVH8	CHX0835	FTKA0612	HW50L	SC83V
5050-T25	50	50	300	60	50	47		SPR1018	CVH8	CHX0835	FTKA0612	HW50L	SC83V

DDJNR/L

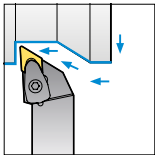

Rechtsausführung
93°

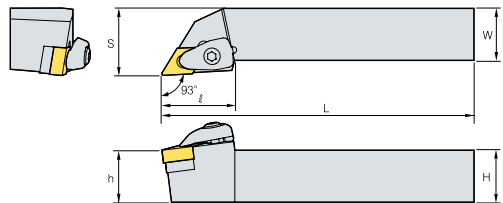

WSP



DN_

(mm)

Bezeichnung	H	W	L	S	h	ℓ	WSP	Feder	Klemme	Klemmschraube	Lagenschraube	Schlüssel	Zwischenlage
DDJNR/L 2020-K11	20	20	125	25	20	30	DN_1104_	SPR0510	CVH3	CHX0415	FTKA0307	HW25P	SD32V
2020-K15	20	20	125	25	20	35	DN_1506_	SPR0714	CVH4	CHX0518	FTKA0410	HW30P	SD43V
2020-K15-3	20	20	125	25	20	35	DN_1504_	SPR0714	CVH4	CHX0518	FTKA0410	HW30P	SD44V
2525-M11	25	25	150	32	25	30	DN_1104_	SPR0510	CVH3	CHX0415	FTKA0307	HW25P	SD32V
2525-M15	25	25	150	32	25	35	DN_1506_	SPR0714	CVH4	CHX0518	FTKA0410	HW30P	SD43V
2525-M15-3	25	25	150	32	25	35	DN_1504_	SPR0714	CVH4	CHX0518	FTKA0410	HW30P	SD44V
3225-M15	32	25	150	32	32	35	DN_1506_	SPR0714	CVH4	CHX0518	FTKA0410	HW30P	SD43V
3225-P11	32	25	170	32	32	30	DN_1104_	SPR0510	CVH3	CHX0415	FTKA0307	HW25P	SD32V
3225-P15	32	25	170	32	32	35	DN_1506_	SPR0714	CVH4	CHX0518	FTKA0410	HW30P	SD43V
3232-M15	32	32	150	40	32	35		SPR0714	CVH4	CHX0518	FTKA0410	HW30P	SD43V
3232-P11	32	32	170	40	32	30	DN_1104_	SPR0510	CVH3	CHX0415	FTKA0307	HW25P	SD32V
3232-P15	32	32	170	40	32	35	DN_1506_	SPR0714	CVH4	CHX0518	FTKA0410	HW30P	SD43V
3232-P15-3	32	32	170	40	32	35	DN_1504_	SPR0714	CVH4	CHX0518	FTKA0410	HW30P	SD44V
4040-S15	40	40	250	50	40	35	DN_1506_	SPR0714	CVH4	CHX0518	FTKA0410	HW30P	SD43V



DSBNR/L

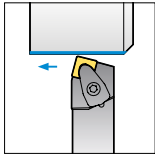

Rechtsausführung

75°

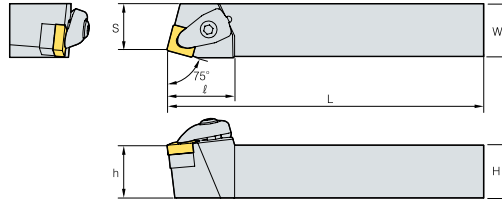

WSP



SN_

(mm)

Bezeichnung	H	W	L	S	h	ℓ	WSP	Feder	Klemme	Klemmschraube	Lagenschraube	Schlüssel	Zwischenlage	
DSBNR/L	2020-K09	20	20	125	17	20	25	SN_0903_	SPR0510	CVH3	CHX0415	FTKA0307	HW25P	SS32V
	2020-K12	20	20	125	17	20	32	SN_1204_	SPR0714	CVH4	CHX0518	FTKA0410	HW30P	SS44V
	2525-M09	25	25	150	22	25	25	SN_0903_	SPR0510	CVH3	CHX0415	FTKA0307	HW25P	SS32V
	2525-M12	25	25	150	22	25	32	SN_1204_	SPR0714	CVH4	CHX0518	FTKA0410	HW30P	SS44V
	2525-M15	25	25	150	22	25	38	SN_1506_	SPR0811	CVH5	CHX0622	FTKA0511	HW40L	SS54V
	3225-P12	32	25	170	22	32	32	SN_1204_	SPR0714	CVH4	CHX0518	FTKA0410	HW30P	SS44V
	3225-P15	32	25	170	22	32	38	SN_1506_	SPR0811	CVH5	CHX0622	FTKA0511	HW40L	SS54V
	3232-P12	32	32	170	27	32	32	SN_1204_	SPR0714	CVH4	CHX0518	FTKA0410	HW30P	SS44V
	3232-P15	32	32	170	27	32	38	SN_1506_	SPR0811	CVH5	CHX0622	FTKA0511	HW40L	SS54V
	3232-P19	32	32	170	27	32	43	SN_1906_	SPR0811	CVH6	CHX0622	FTNA0511	HW40L	SS64V
	4040-S19	40	40	250	35	40	43		SPR0811	CVH6	CHX0622	FTNA0511	HW40L	SS64V
	4040-S25	40	40	250	35	40	50	SN_2507_	SPR1018	CVH8	CHX0835	FTKA0612	HW50L	SS84V



DSDNN

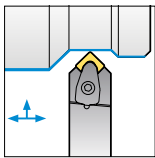

45°

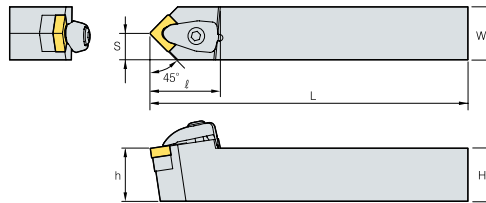

WSP



SN_

(mm)

Bezeichnung	H	W	L	S	h	ℓ	WSP	Feder	Klemme	Klemmschraube	Lagenschraube	Schlüssel	Zwischenlage	
DSDNN	2020-K09	20	20	125	10	20	26,5	SN_0903_	SPR0510	CVH3	CHX0415	FTKA0307	HW25P	SS32V
	2020-K12	20	20	125	10	20	33	SN_1204_	SPR0714	CVH4	CHX0518	FTKA0410	HW30P	SS44V
	2525-M12	25	25	150	12,5	25	33		SPR0714	CVH4	CHX0518	FTKA0410	HW30P	SS44V
	2525-M15	25	25	150	12,5	25	39,4	SN_1506_	SPR0811	CVH5	CHX0622	FTKA0511	HW40L	SS54V
	3225-P12	32	25	170	12,5	32	33	SN_1204_	SPR0714	CVH4	CHX0518	FTKA0410	HW30P	SS44V
	3232-P12	32	32	170	16	32	33		SPR0714	CVH4	CHX0518	FTKA0410	HW30P	SS44V
	3232-P15	32	32	170	16	32	38	SN_1506_	SPR0811	CVH5	CHX0622	FTKA0511	HW40L	SS54V
	3232-P19	32	32	170	16	32	43	SN_1906_	SPR0811	CVH6	CHX0622	FTNA0511	HW40L	SS64V
	4040-S19	40	40	250	20	40	45		SPR0811	CVH6	CHX0622	FTNA0511	HW40L	SS64V



DSKNR/L

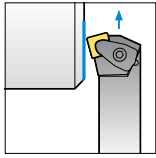

Rechtsausführung
75°

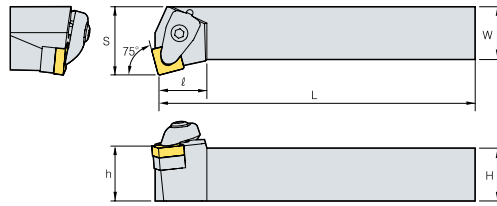

WSP



SN_

(mm)

Bezeichnung	H	W	L	S	h	ℓ	WSP	Feder	Klemme	Klemmschraube	Lagenschraube	Schlüssel	Zwischenlage
DSKNR/L	2020-K09	20	20	125	25	20	SN_0903_	SPR0510	CVH3	CHX0415	FTKA0307	HW25P	SS32V
	2020-K12	20	20	125	25	20	SN_1204_	SPR0714	CVH4	CHX0518	FTKA0410	HW30P	SS44V
	2525-M12	25	25	150	32	25		SPR0714	CVH4	CHX0518	FTKA0410	HW30P	SS44V
	3232-P12	32	32	170	40	32		SPR0714	CVH4	CHX0518	FTKA0410	HW30P	SS44V
	3232-P15	32	32	170	40	32	SN_1506_	SPR0811	CVH5	CHX0622	FTNA0511	HW40L	SS54V
	3232-P19	32	32	170	40	32		SPR0811	CVH6	CHX0622	FTNA0511	HW40L	SS64V
	4040-S19	40	40	250	50	40	SN_1906_	SPR0811	CVH6	CHX0622	FTNA0511	HW40L	SS64V

DSSNR/L

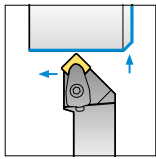

Rechtsausführung
45°

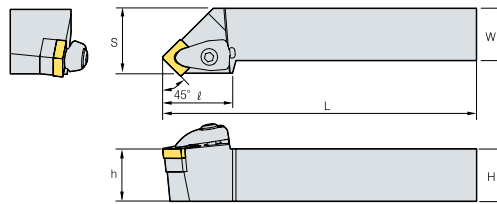

WSP



SN_

(mm)

Bezeichnung	H	W	L	S	h	ℓ	WSP	Feder	Klemme	Klemmschraube	Lagenschraube	Schlüssel	Zwischenlage
DSSNR/L	2020-K09	20	20	125	25	20	SN_0903_	SPR0510	CVH3	CHX0415	FTKA0307	HW25P	SS32V
	2020-K12	20	20	125	25	20	SN_1204_	SPR0714	CVH4	CHX0518	FTKA0410	HW30P	SS44V
	2525-M12	25	25	150	32	25		SPR0714	CVH4	CHX0518	FTKA0410	HW30P	SS44V
	2525-M15	25	25	150	32	25	SN_1506_	SPR0811	CVH5	CHX0622	FTKA0511	HW40L	SS54V
	3225-P12	32	25	170	32	32	SN_1204_	SPR0714	CVH4	CHX0518	FTKA0410	HW30P	SS44V
	3232-P12	32	32	170	40	32		SPR0714	CVH4	CHX0518	FTKA0410	HW30P	SS44V
	3232-P15	32	32	170	40	32	SN_1506_	SPR0811	CVH5	CHX0622	FTKA0511	HW40L	SS54V
	3232-P19	32	32	170	40	32	SN_1906_	SPR0811	CVH6	CHX0622	FTNA0511	HW40L	SS64V
	4040-S19	40	40	250	50	40		SPR0811	CVH6	CHX0622	FTNA0511	HW40L	SS64V



DTFNR/L

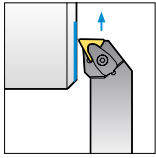

90°

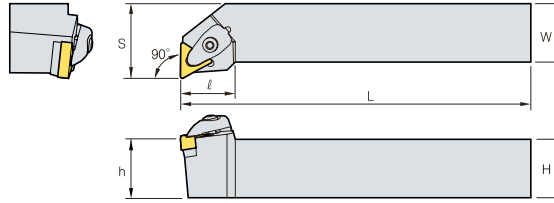

WSP



TN_

Bezeichnung	H	W	L	S	h	ℓ	WSP	Feder	Klemme	Klemmschraube	Lagenschraube	Schlüssel	Zwischenlage
DTFNR/L 2020-K16	20	20	125	25	20	24,5	TN_1604_	SPR0510	CVH3	CHX0415	FTKA0307	HW25P	ST32V
	2525-M16	25	25	150	32	25	24,5		SPR0510	CVH3	CHX0415	FTKA0307	HW25P
2525-M22	25	25	150	32	25	33	TN_2204_	SPR0714	CVH4	CHX0518	FTKA0410	HW30P	ST44V
3225-P22	32	25	170	32	32	33		SPR0714	CVH4	CHX0518	FTKA0410	HW30P	ST44V
3232-P16	32	32	170	40	32	23,5	TN_1604_	SPR0510	CVH3	CHX0415	FTKA0307	HW25P	ST32V
3232-P22	32	32	170	40	32	33	TN_2204_	SPR0714	CVH4	CHX0518	FTKA0410	HW30P	ST44V

(mm)

DTGNR/L

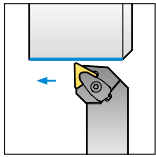

90°

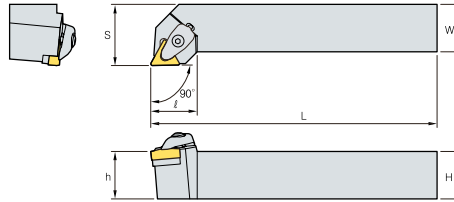

WSP



TN_

Bezeichnung	H	W	L	S	h	ℓ	WSP	Feder	Klemme	Klemmschraube	Lagenschraube	Schlüssel	Zwischenlage
DTGNR/L 2020-K16	20	20	125	25	20	24,5	TN_1604_	SPR0510	CVH3	CHX0415	FTKA0307	HW25P	ST32V
	2525-M16	25	25	150	32	25	24,5		SPR0510	CVH3	CHX0415	FTKA0307	HW25P
2525-M22	25	25	150	32	25	32,6	TN_2204_	SPR0714	CVH4	CHX0518	FTKA0410	HW30P	ST44V
3225-P22	32	25	170	32	32	32,6		SPR0714	CVH4	CHX0518	FTKA0410	HW30P	ST44V
3232-P16	32	32	170	40	32	24,5	TN_1604_	SPR0510	CVH3	CHX0415	FTKA0307	HW25P	ST32V
3232-P22	32	32	170	40	32	32,6	TN_2204_	SPR0714	CVH4	CHX0518	FTKA0410	HW30P	ST44V

(mm)

DTJNR/L

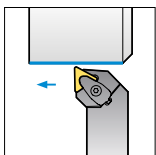

93°

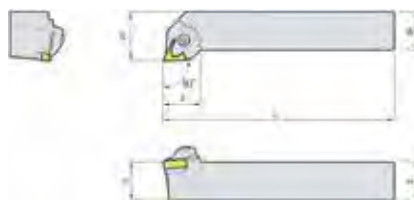

WSP



TN_

Bezeichnung	H	W	L	S	h	ℓ	WSP	Feder	Klemme	Klemmschraube	Lagenschraube	Schlüssel	Zwischenlage
DTJNR/L 2020-K16	20	20	125	25	20	24,5	TN_1604_	SPR0510	CVH3	CHX0415	FTKA0307	HW25P	ST32V
	2525-M16	25	25	150	32	25	24,5		SPR0510	CVH3	CHX0415	FTKA0307	HW25P
2525-M22	25	25	150	32	25	32,6	TN_2204_	SPR0714	CVH4	CHX0518	FTKA0410	HW30P	ST44V
3232-P16	32	32	170	40	32	24,5	TN_1604_	SPR0510	CVH3	CHX0415	FTKA0307	HW25P	ST32V
3232-P22	32	32	170	40	32	32,6	TN_2204_	SPR0714	CVH4	CHX0518	FTKA0410	HW30P	ST44V

(mm)



DVJNR/L

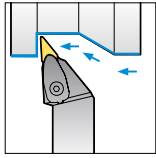

93°

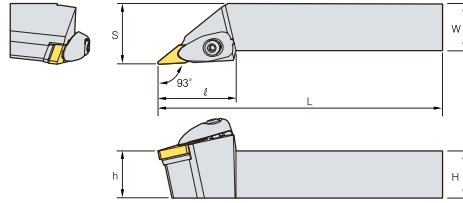

WSP



VN_

Bezeichnung		H	W	L	S	h	ℓ	WSP	Feder	Klemme	Klemmschraube	Lagenschraube	Schlüssel	Zwischenlage
DVJNR/L	2020-K16	20	20	125	25	20	41,5	VN_1604_	SPR0714	CVH3V	CHX0518	FTNA03508	HW30P	SV32V
	2525-M16	25	25	150	32	25	41,5		SPR0714	CVH3V	CHX0518	FTNA03508	HW30P	SV32V
	3232-P16	32	32	170	40	32	41,5		SPR0714	CVH3V	CHX0518	FTNA03508	HW30P	SV32V

(mm)

DVVNN

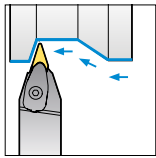

72,5°

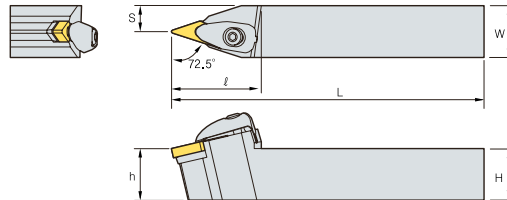

WSP



VN_

Bezeichnung		H	W	L	S	h	ℓ	WSP	Feder	Klemme	Klemmschraube	Lagenschraube	Schlüssel	Zwischenlage
DVVNN	2020-K16	20	20	125	10	20	40	VN_1604_	SPR0714	CVH3V	CHX0518	FTNA03508	HW30P	SV32V
	2525-M16	25	25	150	12,5	25	40		SPR0714	CVH3V	CHX0518	FTNA03508	HW30P	SV32V
	3232-P16	32	32	170	16	32	40		SPR0714	CVH3V	CHX0518	FTNA03508	HW30P	SV32V

(mm)

DWLNR/L

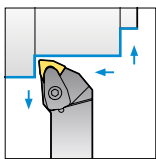

95°

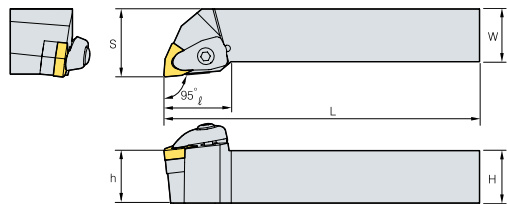

WSP



WN_

Bezeichnung		H	W	L	S	h	ℓ	WSP	Feder	Klemme	Klemmschraube	Lagenschraube	Schlüssel	Zwischenlage
DWLNR/L	2020-K06	20	20	125	25	20	26	WN_T0604_	SPR0510	CVH3	CHX0415	FTKA0307	HW25P	SW32V
	2020-K08	20	20	125	25	20	32	WN_0804_	SPR0714	CVH4	CHX0518	FTKA0410	HW30P	SW44V
	2525-M06	25	25	150	32	25	26	WN_T0604_	SPR0510	CVH3	CHX0415	FTKA0307	HW25P	SW32V
	2525-M08	25	25	150	32	25	32	WN_0804_	SPR0714	CVH4	CHX0518	FTKA0410	HW30P	SW44V

(mm)



PCBNR/L

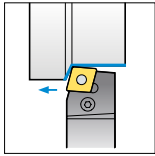

75°

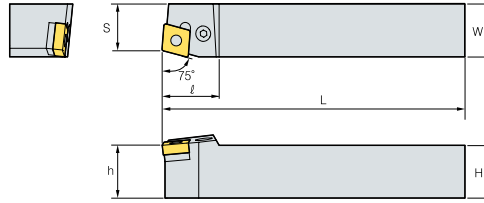

WSP



CN_

(mm)

Bezeichnung	H	W	L	S	h	ℓ	WSP	Kniehebel	Rohrstift	Rohrstift-Dorn	Schlüssel	Schraube	Zwischenlage	
PCBNR/L	2020-K09-4N	20	20	125	17	20	27	CN_0903_	LV4	SP4	LSPS8	HW30L	VHX0821	SC42
	2020-K12	20	20	125	17	20	27	CN_1204_	LV4	SP4	LSPS8	HW30L	VHX0821	SC42
	2020-K12N	20	20	125	17	20	27		LV4N	SP4N	LSPS4	HW30L	VHX0820N	SC42N
	2525-M09-4N	20	20	125	17	20	27	CN_0903_	LV4N	SP4N	LSPS4	HW30L	VHX0820N	SC42N
	2525-M12	25	25	150	22	25	27	CN_1204_	LV4	SP4	LSPS8	HW30L	VHX0821	SC42
	2525-M12N	25	25	150	22	25	27		LV4N	SP4N	LSPS4	HW30L	VHX0820N	SC42N
	2525-M16	25	25	150	22	25	33	CN_1606_	LV5	SP5	LSPS6	HW30L	VHX0825	SC53
	2525-M16N	25	25	150	22	25	33		LV5N	SP5N	LSPS5	HW30L	VHX0820AN	SC53N
	2525-M19	25	25	150	22	25		CN_1906_	LV6N	SP6N	LSPS6	HW40L	VHX1027N	SC63N
	3225-P12	32	25	170	22	32	27	CN_1204_	LV4	SP4	LSPS8	HW30L	VHX0821	SC42
	3225-P12N	32	25	170	22	32	27		LV4N	SP4N	LSPS4	HW30L	VHX0820N	SC42N
	3232-P16	32	32	170	27	32	33	CN_1606_	LV5	SP5	LSPS6	HW30L	VHX0825	SC53
	3232-P16N	32	32	170	27	32	33		LV5N	SP5N	LSPS5	HW30L	VHX0820AN	SC53N
	3232-P19	32	32	170	27	32	36	CN_1906_	LV6N	SP6N	LSPS6	HW40L	VHX1027N	SC63N
	3232-P19N	32	32	170	27	32	36		LV6N	SP6N	LSPS6	HW40L	VHX1027N	SC63N
	3232-T19	32	32	300	27	32	36		LV6N	SP6N	LSPS6	HW40L	VHX1027N	SC63N
	4040-S19	40	40	250	35	40	36		LV6N	SP6N	LSPS6	HW40L	VHX1027N	SC63N
	4040-S19N	40	40	250	35	40	36		LV6N	SP6N	LSPS6	HW40L	VHX1027N	SC63N
	4040-S25	40	40	250	35	40	47	CN_2509_	LV8N	SP8N	LSPS8	HW50L	VHX1236N	SC84N
	4040-S25-5	40	40	250	35	40	47	CN_2507_	LV8N	SP8N	LSPS8	HW50L	VHX1236N	SC84N
4040-S25-5N	40	40	250	35	40	47		LV8N	SP8N	LSPS8	HW50L	VHX1236N	SC84N	
4040-S25N	40	40	250	35	40	47	CN_2509_	LV8N	SP8N	LSPS8	HW50L	VHX1236N	SC84N	
5050-T250	50	50	300	47	50	50		LV8N	SP8N	LSPS8	HW50L	VHX1236N	SC84N	



PCKNR/L

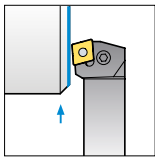

75°

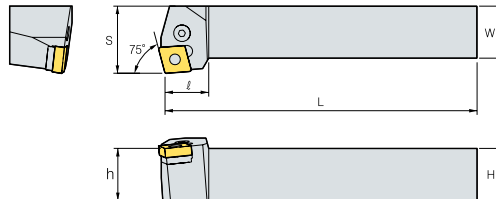

WSP



CN_

(mm)

Bezeichnung	H	W	L	S	h	ℓ	WSP	Kniehebel	Rohrstift	Rohrstift-Dorn	Schlüssel	Schraube	Zwischenlage	
PCKNR/L	2020-K12	20	20	125	25	20	27	CN_1204_	LV4	SP4	LSPS4	HW30L	VHX0821	SC42
	2020-K12N	20	20	125	25	20	27		LV4N	SP4N	LSPS4	HW30L	VHX0820N	SC42N
	2525-M12	25	25	150	32	25	27		LV4	SP4	LSPS4	HW30L	VHX0821	SC42
	2525-M12N	25	25	150	32	25	27		LV4N	SP4N	LSPS4	HW30L	VHX0820N	SC42N
	3225-P12	32	25	170	40	32	30		LV4	SP4	LSPS4	HW30L	VHX0821	SC42
	3225-P12N	32	25	170	40	32	30		LV4N	SP4N	LSPS4	HW30L	VHX0820N	SC42N
	3232-P16	32	32	170	40	32	26	CN_1606_	LV5	SP5	LSPS5	HW30L	VHX0825	SC53
	3232-P16N	32	32	170	40	32	26		LV5N	SP5N	LSPS5	HW30L	VHX0820AN	SC53N
	4040-S16	40	40	250	50	40	25		LV5	SP5	LSPS5	HW30L	VHX0825	SC53
	4040-S16N	40	40	250	50	40	25		LV5N	SP5N	LSPS5	HW30L	VHX0820AN	SC53N



PCLNR/L

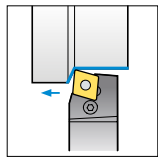

95°

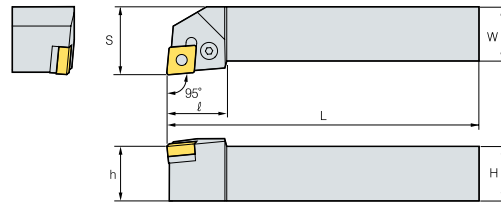

WSP



CN_

(mm)

Bezeichnung	H	W	L	S	h	ℓ	WSP	Kniehebel	Rohrstift	Rohrstift-Dorn	Schlüssel	Schraube	Zwischenlage
PCLNR/L 1616-H09	16	16	100	20	16	20	CN_0903_	LV3	SP3	LSPS3	HW25L	VHX0617	SC32
1616-H09-4N	16	16	100	20	16	20	CN_0904_	LV3N	SP3N	LSPS3	HW25L	VHX0617N	SC32N
1616-H09N	16	16	100	20	16	20	CN_0903_	LV3N	SP3N	LSPS3	HW25L	VHX0617N	SC32N
1616-H12	16	16	100	20	16	28	CN_1204_	LV4	SP4	LSPS4	HW30L	VHX0821	SC42
1616-H12N	16	16	100	20	16	28		LV4N	SP4N	LSPS4	HW30L	VHX0817N	SC42N
2020-K09	20	20	125	25	20	22	CN_0903_	LV3	SP3	LSPS3	HW25L	VHX0617	SC32
2020-K09-4N	20	20	125	25	20	22	CN_0904_	LV3N	SP3N	LSPS3	HW25L	VHX0617N	SC32N
2020-K09N	20	20	125	25	20	22	CN_0903_	LV3N	SP3N	LSPS3	HW25L	VHX0617N	SC32N
2020-K12	20	20	125	25	20	28	CN_1204_	LV4	SP4	LSPS4	HW30L	VHX0821	SC42
2020-K12N	20	20	125	25	20	28		LV4N	SP4N	LSPS4	HW30L	VHX0820N	SC42N
2525-M09	25	25	150	32	25	22	CN_0903_	LV3	SP3	LSPS3	HW25L	VHX0617	SC32
2525-K09-4N	25	25	150	32	25	22	CN_0904_	LV3N	SP3N	LSPS3	HW25L	VHX0617N	SC32N
2525-M09N	25	25	150	32	25	22	CN_0903_	LV3N	SP3N	LSPS3	HW25L	VHX0617N	SC32N
2525-M12	25	25	150	32	25	28	CN_1204_	LV4	SP4	LSPS4	HW30L	VHX0821	SC42
2525-M12N	25	25	150	32	25	28		LV4N	SP4N	LSPS4	HW30L	VHX0820N	SC42N
2525-M16	25	25	150	32	25	33	CN_1606_	LV5	SP5	LSPS5	HW30L	VHX0825	SC53
2525-M16N	25	25	150	32	25	33		LV5N	SP5N	LSPS5	HW30L	VHX0820AN	SC53N
2525-M19	25	25	150	32	25	36	CN_1906_	LV6N	SP6N	LSPS6	HW40L	VHX1027N	SC63N
2525-M19N	25	25	150	32	25	36		LV6N	SP6N	LSPS6	HW40L	VHX1027N	SC63N
3225-P12	32	25	170	32	32	28	CN_1204_	LV4	SP4	LSPS4	HW30L	VHX0821	SC42
3225-P12N	32	25	170	32	32	28		LV4N	SP4N	LSPS4	HW30L	VHX0820N	SC42N
3225-P19	32	25	170	32	32	36	CN_1906_	LV6N	SP6N	LSPS6	HW40L	VHX1027N	SC63N
3225-P19N	32	25	170	32	32	36		LV6N	SP6N	LSPS6	HW40L	VHX1027N	SC63N
3232-P12	32	32	170	40	32	28	CN_1204_	LV4	SP4	LSPS4	HW30L	VHX0821	SC42
3232-P12N	32	32	170	40	32	28		LV4N	SP4N	LSPS4	HW30L	VHX0820N	SC42N
3232-P16	32	32	170	40	32	33	CN_1606_	LV5	SP5	LSPS5	HW30L	VHX0825	SC53
3232-P16N	32	32	170	40	32	33		LV5N	SP5N	LSPS5	HW30L	VHX0820AN	SC53N
3232-P19	32	32	170	40	32	36	CN_1906_	LV6N	SP6N	LSPS6	HW40L	VHX1027N	SC63N
3232-P19N	32	32	170	40	32	36		LV6N	SP6N	LSPS6	HW40L	VHX1027N	SC63N
4040-P19	40	40	170	50	40	36		LV6N	SP6N	LSPS6	HW40L	VHX1027N	SC63N
4040-P19N	40	40	170	50	40	36		LV6N	SP6N	LSPS6	HW40L	VHX1027N	SC63N
4040-S19	40	40	250	50	40	36		LV6N	SP6N	LSPS6	HW40L	VHX1027N	SC63N
4040-S19N	40	40	250	50	40	36		LV6N	SP6N	LSPS6	HW40L	VHX1027N	SC63N
4040-S25	40	40	250	50	40	47	CN_2509_	LV8N	SP8N	LSPS8	HW50L	VHX1236N	SC84N
4040-S25-5	40	40	250	50	40	47	CN_2507_	LV8N	SP8N	LSPS8	HW50L	VHX1236N	SC84N
4040-S25-5N	40	40	250	50	40	47		LV8N	SP8N	LSPS8	HW50L	VHX1236N	SC84N
4040-S25N	40	40	250	50	40	47	CN_2509_	LV8N	SP8N	LSPS8	HW50L	VHX1236N	SC84N
5050-S25-5	50	50	300	60	50	47	CN_2507_	LV8N	SP8N	LSPS8	HW50L	VHX1236N	SC84N
5050-T25	50	50	300	60	50	47	CN_2509_	LV8N	SP8N	LSPS8	HW50L	VHX1236N	SC84N
5050-T25-5	50	50	300	60	50	47	CN_2507_	LV8N	SP8N	LSPS8	HW50L	VHX1236N	SC84N
5050-T25-5N	50	50	300	60	50	47		LV8N	SP8N	LSPS8	HW50L	VHX1236N	SC84N
5050-T25N	50	50	300	60	50	47	CN_2509_	LV8N	SP8N	LSPS8	HW50L	VHX1236N	SC84N



PDJNR/L

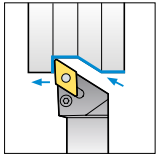

93°

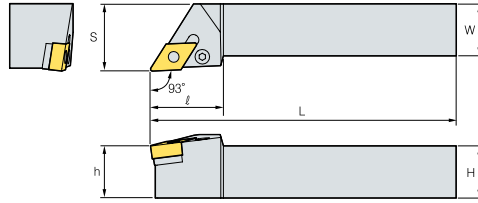

WSP



DN_

(mm)

Bezeichnung	H	W	L	S	h	ℓ	WSP	Kniehebel	Rohrstift	Rohrstift-Dorn	Schlüssel	Schraube	Zwischenlage
PDJNR/L 1616-H11	16	16	100	20	16	25	DN_1104_	LV3	SP3	LSPS3	HW25L	VHX0617	SD317
	16	16	100	20	16	25		LV3AN	SP3N-1	LSPS3	HW25L	VHX0617N	SD32N
2020-K11	20	20	125	25	20	25	DN_1105_	LV3	SP3	LSPS3	HW25L	VHX0617	SD317
2020-K11-5N	20	20	125	25	20	25		LV3AN	SP3N-1	LSPS3	HW25L	VHX0617N	SD32N
2020-K15	20	20	125	25	20	35	DN_1506_	LV4B	SP4	LSPS4	HW30L	VHX0821	SD42
2020-K15N	20	20	125	25	20	35		LV4BN	SP4N	LSPS4	HW30L	VHX0821N	SD42N
2020-K15-3	20	20	125	25	20	35	DN_1504_	LV4B	SP4	LSPS4	HW30L	VHX0821	SD42
2020-K15-3N	20	20	125	25	20	35		LV4BN	SP4N	LSPS4	HW30L	VHX0821N	SD43N
2525-M11	25	25	150	32	25	30	DN_1104_	LV3	SP3	LSPS3	HW25L	VHX0617	SD317
2525-M11-5N	25	25	150	32	25	30		LV3	SP3	LSPS3	HW25L	VHX0617	SD317
2525-M11N	25	25	150	32	25	30	DN_1506_	LV3AN	SP3N-1	LSPS3	HW25L	VHX0617N	SD32N
2525-M15	25	25	150	32	25	35		LV4B	SP4	LSPS4	HW30L	VHX0821	SD42
2525-M15N	25	25	150	32	25	35	LV4BN	SP4N	LSPS4	HW30L	VHX0821N	SD42N	
2525-M15-3	25	25	150	32	25	35	DN_1504_	LV4	SP4	LSPS4	HW30L	VHX0821	SD42
2525-M15-3N	25	25	150	32	25	35		LV4BN	SP4N	LSPS4	HW30L	VHX0821N	SD43N
3225-P15	32	25	170	32	32	35	DN_1506_	LV4B	SP4	LSPS4	HW30L	VHX0821	SD42
3225-P15N	32	25	170	32	32	35		LV4BN	SP4N	LSPS4	HW30L	VHX0821N	SD42N
3232-P15	32	32	170	40	32	35	DN_1504_	LV4B	SP4	LSPS4	HW30L	VHX0821	SD42
3232-P15N	32	32	170	40	32	35		LV4BN	SP4N	LSPS4	HW30L	VHX0821N	SD42N
3232-P15-3	32	32	170	40	32	35	DN_1504_	LV4	SP4	LSPS4	HW30L	VHX0821	SD42
3232-P15-3N	32	32	170	40	32	35		LV4BN	SP4N	LSPS4	HW30L	VHX0821N	SD43N
4040-P15	40	40	170	50	40	45	DN_1506_	LV4B	SP4	LSPS4	HW30L	VHX0821	SD42

PDNNR/L

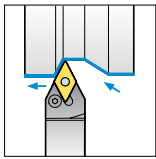

62,5°

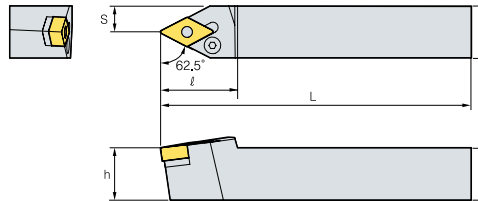

WSP



DN_

(mm)

Bezeichnung	H	W	L	S	h	ℓ	WSP	Kniehebel	Rohrstift	Rohrstift-Dorn	Schlüssel	Schraube	Zwischenlage
PDNNR/L 2020-K11-5N	20	20	125	8	20	37	DN_1105_	LV4B	SP4	LSPS4	HW30L	VHX0821	SD42
2020-K15	20	20	125	8	20	37	DN_1506_	LV4B	SP4	LSPS4	HW30L	VHX0821	SD42
2020-K15N	20	20	125	8	20	37		LV4BN	SP4N	LSPS4	HW30L	VHX0821N	SD42N
2525-M11-5N	25	25	150	12,5	25	37	DN_1105_	LV4B	SP4	LSPS4	HW30L	VHX0821	SD42
2525-M15	25	25	150	12,5	25	37	DN_1506_	LV4B	SP4	LSPS4	HW30L	VHX0821	SD42
2525-M15N	25	25	150	12,5	25	37		LV4BN	SP4N	LSPS4	HW30L	VHX0821N	SD42N
2525-M15-3	25	25	150	12,5	25	37	DN_1504_	LV4	SP4	LSPS4	HW30L	VHX0821	SD42
2525-M15-3N	25	25	150	12,5	25	37		LV4BN	SP4N	LSPS4	HW30L	VHX0821N	SD43N
3232-M15	32	32	150	16	32	37	DN_1506_	LV4B	SP4	LSPS4	HW30L	VHX0821	SD42
3232-P15	32	32	170	16	32	37		LV4B	SP4	LSPS4	HW30L	VHX0821	SD42
3232-P15N	32	32	170	16	32	37	DN_1504_	LV4BN	SP4N	LSPS4	HW30L	VHX0821N	SD42N
3232-P15-3N	32	32	170	16	32	37		LV4BN	SP4N	LSPS4	HW30L	VHX0821N	SD43N
4025-M15	40	25	150	12,5	32	37	DN_1506_	LV4B	SP4	LSPS4	HW30L	VHX0821	SD42
4025-M15-3	40	25	150	12,5	25	37	DN_1504_	LV4	SP4	LSPS4	HW30L	VHX0821	SD42



PDNNN

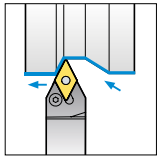

62,5°

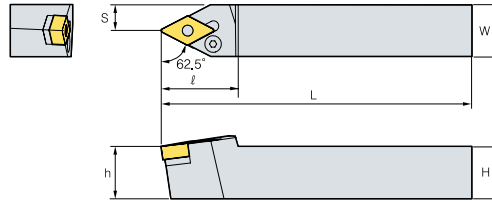

WSP



DN_

(mm)

Bezeichnung	H	W	L	S	h	ℓ	WSP	Kniehebel	Rohrstift	Rohrstift-Dorn	Schlüssel	Schraube	Zwischenlage
PDNNN 3232-S15	32	32	250	16	32	37	DN_1506_	LVB	VHX0821	SD42	SP4	HW030L	LSPS4

PRDCN

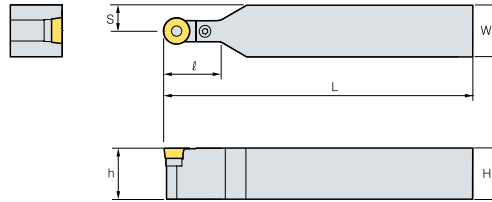
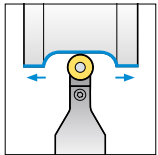

WSP



RCMX

(mm)

Bezeichnung	H	W	L	S	h	ℓ	WSP	Kniehebel	Rohrstift	Rohrstift-Dorn	Schlüssel	Schraube	Zwischenlage
PRDCN 2020-K12	20	20	125	16	20	24	RCMX1204M0	LR12	SP3	LSPS3	HW25L	VHX0617	SR12
2020-M10	20	20	150	15	20	24	RCMX1003M0	LR10	SP3	LSPS3	HW20L	VHX0514	SR10
2525-M10	25	25	150	17,5	25	24		LR10	SP3	LSPS3	HW20L	VHX0514	SR10
2525-M12	25	25	150	18,5	25	24	RCMX1204M0	LR12	SP3	LSPS3	HW25L	VHX0617	SR12
2525-Q16	25	25	180	20,5	25	30	RCMX1606M0	LR16	SP4	LSPS4	HW25L	VHX0621	SR16
3225-Q12	32	25	180	18,5	32	24	RCMX1204M0	LR12	SP3	LSPS3	HW25L	VHX0617	SR12
3225-Q16	32	25	180	20,5	32	30	RCMX1606M0	LR16	SP4	LSPS4	HW25L	VHX0621	SR16
3232-Q16	32	32	180	24	32	35		LR16	SP4	LSPS4	HW25L	VHX0621	SR16
3232-Q20	32	32	180	26	32	40	RCMX2006M0	LR20	SP5-1	LSPS5	HW30L	VHX0823	SR20
4040-S25	40	40	250	32,5	40	42	RCMX2507M0	LR25	SP6N	LSPS6	HW40L	VHX1030	SR25
4040-T25	40	40	300	32,5	40	42		LR25	SP6N	LSPS6	HW40L	VHX1030	SR25
5050-U32	50	50	350	41	50	52	RCMX3209M0	LR32	SP8N	LSPS8	HW50L	VHX1236	SR32

PRGCR/L

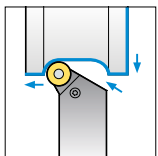

90°

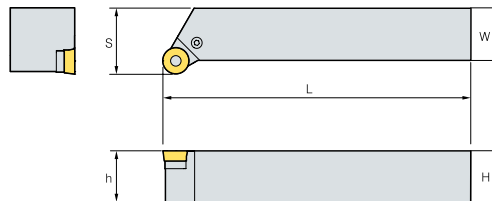

WSP



RCMX

(mm)

Bezeichnung	H	W	L	S	h	WSP	Kniehebel	Rohrstift	Rohrstift-Dorn	Schlüssel	Schraube	Zwischenlage
PRGCR/L 2020-K10	20	20	125	25	20	RCMX1003M0	LR10	SP3	LSPS3	HW20L	VHX0514	SR10
2020-K12	20	20	125	25	20	RCMX1204M0	LR12	SP3	LSPS3	HW25L	VHX0617	SR12
2525-M10	25	25	150	32	25	RCMX1003M0	LR10	SP3	LSPS3	HW20L	VHX0514	SR10
2525-M12	25	25	150	32	25	RCMX1204M0	LR12	SP3	LSPS3	HW25L	VHX0617	SR12
2525-M16	25	25	150	32	25	RCMX1606M0	LR16	SP4	LSPS4	HW25L	VHX0621	SR16
3225-P12	32	25	170	32	32	RCMX1204M0	LR12	SP3	LSPS3	HW25L	VHX0617	SR12
3225-P16	32	25	170	32	32	RCMX1606M0	LR16	SP4	LSPS4	HW25L	VHX0621	SR16
3232-P20	32	32	170	40	32	RCMX2006M0	LR20	SP5-1	LSPS5	HW30L	VHX0823	SR20
4040-S25	40	40	250	50	40	RCMX2507M0	LR25	SP6N	LSPS6	HW40L	VHX1030	SR25



PSBNR/L

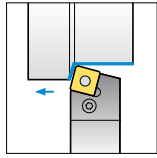

75°

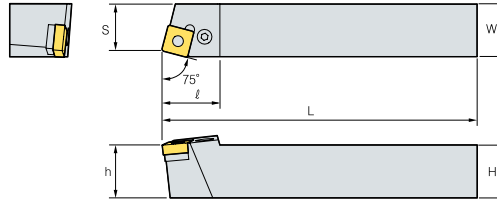

WSP



SN_

(mm)

Bezeichnung	H	W	L	S	h	ℓ	WSP	Kniehebel	Rohrstift	Rohrstift-Dorn	Schlüssel	Schraube	Zwischenlage
PSBNR/L 1616-H09	16	16	100	13	16	21	SN_0903_	LV3	SP3	LSPS3	HW25L	VHX0617	SS32
1616-H09N	16	16	100	13	16	21		LV3N	SP3N	LSPS3	HW25L	VHX0617N	SS32N
2020-K09	20	20	125	17	20	23		LV3	SP3	LSPS3	HW25L	VHX0617	SS32
2020-K09-4N	20	20	125	17	20	23	SN_0904_	LV3	SP3	LSPS3	HW25L	VHX0617	SS32
2020-K09N	20	20	125	17	20	23	SN_0903_	LV3N	SP3N	LSPS3	HW25L	VHX0617N	SS32N
2020-K12	20	20	125	17	20	28	SN_1204_	LV4	SP4	LSPS4	HW30L	VHX0821	SS42
2020-K12N	20	20	125	17	20	28		LV4N	SP4N	LSPS4	HW30L	VHX0820N	SS42N
2525-M09-4N	25	25	150	22	25	28	SN_0904_	LV4	SP4	LSPS4	HW30L	VHX0821	SS42
2525-M12	25	25	150	22	25	28	SN_1204_	LV4	SP4	LSPS4	HW30L	VHX0821	SS42
2525-M12N	25	25	150	22	25	28		LV4N	SP4N	LSPS4	HW30L	VHX0820N	SS42N
2525-M15	25	25	150	22	25	35	SN_1506_	LV5	SP5	LSPS5	HW30L	VHX0825	SS53
2525-M15N	25	25	150	22	25	35		LV5N	SP5N	LSPS5	HW30L	VHX0820AN	SS53N
3225-P12	32	32	170	22	32	28	SN_1204_	LV4	SP4	LSPS4	HW30L	VHX0821	SS42
3225-P12N	32	25	170	22	25	28		LV4N	SP4N	LSPS4	HW30L	VHX0820N	SS42N
3232-P12	32	32	170	27	32	28		LV4	SP4	LSPS4	HW30L	VHX0821	SS42
3232-P12N	32	32	170	27	32	28		LV4N	SP4N	LSPS4	HW30L	VHX0820N	SS42N
3232-P15	32	32	170	27	32	35	SN_1506_	LV5	SP5	LSPS5	HW30L	VHX0825	SS53
3232-P15N	32	32	170	27	32	35		LV5N	SP5N	LSPS5	HW30L	VHX0820AN	SS53N
3232-P19	32	32	170	27	32	40	SN_1906_	LV6N	SP6N	LSPS6	HW40L	VHX1027N	SS63N
4040-S19	40	40	250	35	40	40		LV6N	SP6N	LSPS6	HW40L	VHX1027N	SS63N
4040-S25	40	40	250	35	40	50	SN_2507_	LV8N	SP8N	LSPS8	HW50L	VHX1236N	SS84N
4040-S25-6	40	40	250	35	40	50	SN_2509_	LV8N	SP8N	LSPS8	HW50L	VHX1236N	SS84N
5050-T25	50	50	300	43	50	50	SN_2507_	LV8N	SP8N	LSPS8	HW50L	VHX1236N	SS84N
5050-T25-6	50	50	300	43	50	50	SNMG250924	LV8N	SP8N	LSPS8	HW50L	VHX1026N	SS84N



PSDNN

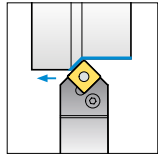

45°

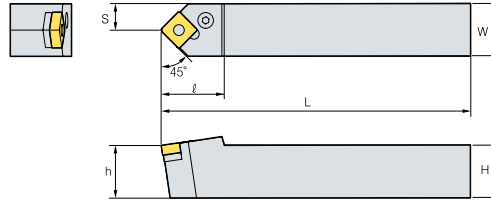

WSP



SN_

(mm)

Bezeichnung	H	W	L	S	h	ℓ	WSP	Kniehebel	Rohrstift	Rohrstift-Dorn	Schlüssel	Schraube	Zwischenlage
PSDNN 1616-H09	16	16	100	8	16	23	SN_0903_	LV3	SP3	LSPS3	HW25L	VHX0617	SS32
1616-H09N	16	16	100	8	16	23		LV3N	SP3N	LSPS3	HW25L	VHX0617N	SS32N
2020-K09-4N	20	20	100	8	16	23	SN_0904_	LV3N	SP3N	LSPS3	HW25L	VHX0617N	SS32N
2020-K12	20	20	125	10	20	30	SN_1204_	LV4	SP4	LSPS4	HW30L	VHX0821	SS42
2020-K12N	20	20	125	10	20	30		LV4N	SP4N	LSPS4	HW30L	VHX0820N	SS42N
2525-M09-4N	25	25	150	12,5	25	30	SN_0904_	LV4	SP4	LSPS4	HW30L	VHX0821	SS42
2525-M12	25	25	150	12,5	25	30	SN_1204_	LV4	SP4	LSPS4	HW30L	VHX0821	SS42
2525-M12N	25	25	150	12,5	20	30		LV4N	SP4N	LSPS4	HW30L	VHX0820N	SS42N
2525-M15	25	25	150	12,5	25	40	SN_1506_	LV5	SP5	LSPS5	HW30L	VHX0825	SS53
2525-M15N	25	25	150	12,5	25	40		LV5N	SP5N	LSPS5	HW30L	VHX0820AN	SS53N
3225-P12	32	25	170	12,5	32	30	SN_1204_	LV4	SP4	LSPS4	HW30L	VHX0821	SS42
3225-P12N	32	25	170	12,5	32	30		LV4N	SP4N	LSPS4	HW30L	VHX0820N	SS42N
3225-P19	32	25	170	12,5	32	40	SN_1906_	LV6N	SP6N	LSPS6	HW40L	VHX1027N	SS63N
3232-P12	32	32	170	16	32	40	SN_1204_	LV4	SP4	LSPS4	HW30L	VHX0821	SS42
3232-P12N	32	32	170	16	32	40		LV4N	SP4N	LSPS4	HW30L	VHX0820N	SS42N
3232-P15	32	32	170	16	32	40	SN_1506_	LV5	SP5	LSPS5	HW30L	VHX0825	SS53
3232-P15N	32	32	170	16	32	40		LV5N	SP5N	LSPS5	HW30L	VHX0820AN	SS53N
3232-P19	32	32	170	16	32	40	SN_1906_	LV6N	SP6N	LSPS6	HW40L	VHX1027N	SS63N
4040-S19	40	40	250	20	40	40		LV6N	SP6N	LSPS6	HW40L	VHX1027N	SS63N
4040-S25	40	40	250	20	40	50	SN_2507_	LV8N	SP8N	LSPS8	HW50L	VHX1236N	SS84N
4040-S25-6	40	40	250	20	40	50	SN_2509_	LV8N	SP8N	LSPS8	HW50L	VHX1236N	SS84N
5050-T25	50	50	300	25	50	50	SN_2507_	LV8N	SP8N	LSPS8	HW50L	VHX1236N	SS84N
5050-T25-6	50	50	300	25	50	50	SN_2509_	LV8N	SP8N	LSPS8	HW50L	VHX1236N	SS84N



PSKNR/L

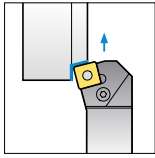

75°

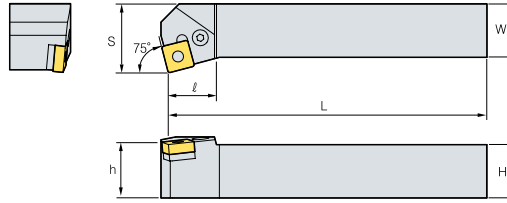

WSP



SN_

(mm)

Bezeichnung	H	W	L	S	h	ℓ	WSP	Kniehebel	Rohrstift	Rohrstift-Dorn	Schlüssel	Schraube	Zwischenlage
PSKNR/L 1616-H09	16	16	100	20	16	17	SN_0903_	LV3	SP3	LSPS3	HW25L	VHX0617	SS32
	16	16	100	20	16	17		LV3N	SP3N	LSPS3	HW25L	VHX0617N	SS32N
2020-K09	20	20	125	25	20	20		LV3	SP3	LSPS3	HW25L	VHX0617	SS32
2020-K09-4N	20	20	125	25	20	20	SN_0904_	LV3	SP3	LSPS3	HW25L	VHX0617	SS32
2020-K09N	20	20	125	25	20	20	SN_0903_	LV3N	SP3N	LSPS3	HW25L	VHX0617N	SS32N
2020-K12	20	20	125	25	20	23	SN_1204_	LV4	SP4	LSPS4	HW30L	VHX0821	SS42
2020-K12N	20	20	125	25	20	26		LV4N	SP4N	LSPS4	HW30L	VHX0820N	SS42N
2525-M09-4N	25	25	150	32	25	23	SN_0904_	LV4	SP4	LSPS4	HW30L	VHX0821	SS42
2525-M12	25	25	150	32	25	23	SN_1204_	LV4	SP4	LSPS4	HW30L	VHX0821	SS42
2525-M12N	25	25	150	32	25	26		LV4N	SP4N	LSPS4	HW30L	VHX0820N	SS42N
2525-M15	25	25	150	32	25	28	SN_1506_	LV5	SP5	LSPS5	HW30L	VHX0825	SS53
2525-M15N	25	25	150	32	25	32		LV5N	SP5N	LSPS5	HW30L	VHX0820AN	SS53N
3232-P12	32	32	170	40	32	23	SN_1204_	LV4	SP4	LSPS4	HW30L	VHX0821	SS42
3232-P12N	32	32	170	40	32	26		LV4N	SP4N	LSPS4	HW30L	VHX0820N	SS42N
3232-P15	32	32	170	40	32	28	SN_1506_	LV5	SP5	LSPS5	HW30L	VHX0825	SS53
3232-P15N	32	32	170	40	32	32		LV5N	SP5N	LSPS5	HW30L	VHX0820AN	SS53N
3232-P19	32	32	170	40	32	41,5	SN_1906_	LV6N	SP6N	LSPS6	HW40L	VHX1027N	SS63N
4040-S19	40	40	250	50	40	41,5		LV6N	SP6N	LSPS6	HW40L	VHX1027N	SS63N
4040-S25	40	40	250	50	40	46	SN_2507_	LV8N	SP8N	LSPS8	HW50L	VHX1236N	SS84N
4040-S25-6	40	40	250	50	40	46	SN_2509_	LV8N	SP8N	LSPS8	HW50L	VHX1236N	SS84N
5050-T25-6	50	50	300	60	50	37,5		LV8N	SP8N	LSPS8	HW50L	VHX1236N	SS84N



PSSNR/L

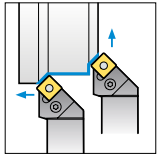

45°

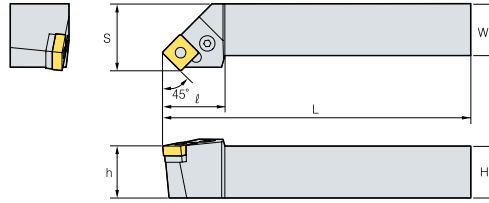

WSP



SN_

Bezeichnung		H	W	L	S	h	ℓ	WSP	Kniehebel	Rohrstift	Rohrstift-Dorn	Schlüssel	Schraube	Zwischenlage
PSSNR/L	1616-H09	16	16	100	20	16	25	SN_0903_	LV3	SP3	LSPS3	HW25L	VHX0617	SS32
	1616-H09N	16	16	100	20	16	25		LV3N	SP3	LSPS3	HW25L	VHX0617N	SS32N
	2020-K09-4N	20	20	125	25	20	30	SN_0904_	LV4	SP4	LSPS4	HW30L	VHX0821	SS42
	2020-K12	20	20	125	25	20	30	SN_1204_	LV4	SP4	LSPS4	HW30L	VHX0821	SS42
	2020-K12N	20	20	125	25	20	30		LV4N	SP4	LSPS4	HW30L	VHX0821N	SS42N
	2525-M09-4N	25	25	150	32	25	36	SN_0904_	LV4	SP4	LSPS4	HW30L	VHX0821	SS42
	2525-M12	25	25	150	32	25	36	SN_1204_	LV4	SP4	LSPS4	HW30L	VHX0821	SS42
	2525-M12N	25	25	150	32	25	36		LV4N	SP4	LSPS4	HW30L	VHX0821N	SS42N
	2525-M15	25	25	150	32	25	36	SN_1506_	LV5	SP5	LSPS5	HW30L	VHX0825	SS53
	2525-M15N	25	25	150	32	25	36		LV5N	SP5	LSPS5	HW30L	VHX08209N	SS53N
	3225-P12	32	25	170	40	32	35	SN_1204_	LV4	SP4	LSPS4	HW30L	VHX0821	SS42
	3225-P12N	32	25	170	32	32	45		LV4N	SP4	LSPS4	HW30L	VHX0821N	SS42N
	3232-P12	32	32	170	40	32	40		LV4	SP4	LSPS4	HW30L	VHX0821	SS42
	3232-P12N	32	32	170	40	32	40		LV4N	SP4	LSPS4	HW30L	VHX0821N	SS42N
	3232-P15	32	32	170	40	32	45	SN_1506_	LV5	SP5	LSPS5	HW30L	VHX0825	SS53
	3232-P15N	32	32	170	40	32	45		LV5N	SP5	LSPS5	HW30L	VHX08209N	SS53N
	3232-P19	32	32	170	40	32	41,5	SN_1906_	LV6N	SP6N	LSPS6	HW40L	VHX1027N	SS63N
	4040-P25	40	40	170	50	40	48	SN_2507_	LV8N	SP8N	LSPS8	HW50L	VHX1236N	SS84N
	4040-R19	40	40	200	50	40	41,5	SN_1906_	LV6N	SP6N	LSPS6	HW40L	VHX1027N	SS63N
	4040-S19	40	40	250	50	40	41,5		LV6N	SP6N	LSPS6	HW40L	VHX1027N	SS63N
4040-S25	40	40	250	50	40	48	SN_2507_	LV8N	SP8N	LSPS8	HW50L	VHX1236N	SS84N	
4040-S25-6	40	40	250	50	40	48	SN_2509_	LV8N	SP8N	LSPS8	HW50L	VHX1236N	SS84N	

(mm)

PTFNR/L

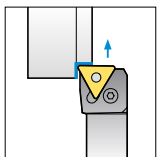

90°

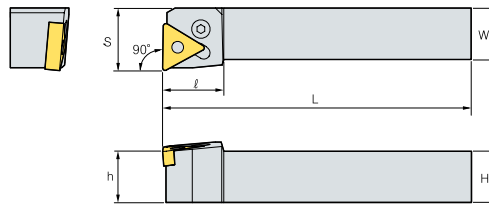

WSP



TN_

Bezeichnung		H	W	L	S	h	ℓ	WSP	Kniehebel	Rohrstift	Rohrstift-Dorn	Schlüssel	Schraube	Zwischenlage
PTFNR/L	1616-H16	16	16	100	20	16	20	TN_1604_	LV3	SP3	LSPS3	HW25L	VHX0617	ST317
	1616-H16N	16	16	100	20	16	20		LV3N	SP3N	LSPS3	HW25L	VHX0617N	ST317N
	2020-K16	20	20	125	25	20	20		LV3	SP3	LSPS3	HW25L	VHX0617	ST317
	2020-K16N	20	20	125	25	20	20		LV3N	SP3N	LSPS3	HW25L	VHX0617N	ST317N
	2525-M16	25	25	150	32	25	20		LV3	SP3	LSPS3	HW25L	VHX0617	ST317
	2525-M16N	25	25	150	32	25	20		LV3N	SP3N	LSPS3	HW25L	VHX0617N	ST317N
	2525-M22	25	25	150	32	25	25	TN_2204_	LV4	SP4	LSPS4	HW30L	VHX0821	ST42
	2525-M22N	25	25	150	32	25	25		LV4N	SP4N	LSPS4	HW30L	VHX0820N	ST42N
	3232-P22	32	32	170	40	32	25		LV4	SP4	LSPS4	HW30L	VHX0821	ST42
	3232-P22N	32	32	170	40	32	25		LV4N	SP4N	LSPS4	HW30L	VHX0820N	ST42N
	3232-P27	32	32	170	40	32	34	TN_2706_	LV5	SP5	LSPS5	HW30L	VHX0825	ST53
	3232-P27N	32	32	170	40	32	34		LV5AN	SP5N	LSPS5	HW30L	VHX0823N	ST53N
	4040-S27	40	40	250	50	40	34		LV5	SP5	LSPS5	HW30L	VHX0825	ST53
	4040-S27N	40	40	250	50	40	34		LV5AN	SP5N	LSPS5	HW30L	VHX0823N	ST53N

(mm)



PTGNR/L

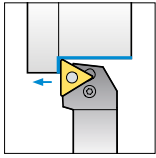

90°

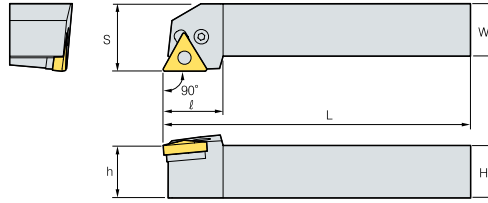

WSP



TN_

(mm)

Bezeichnung	H	W	L	S	h	ℓ	WSP	Kniehebel	Rohrstift	Rohrstift-Dorn	Schlüssel	Schraube	Zwischenlage
PTGNR/L 1212-F11	12	12	80	16	12	16	TN_1103_	LV2			HW20L	VHX0509B	
1616-H11	16	16	100	20	16	18		LV2			HW20L	VHX0509B	
1616-H16	16	16	100	20	16	20	TN_1604_	LV3	SP3	LSPS3	HW25L	VHX0617	ST317
1616-H16N	16	16	100	20	16	20		LV3N	SP3N	LSPS3	HW25L	VHX0617N	ST317N
2020-K11	20	20	125	25	20	19	TN_1103_	LV2			HW20L	VHX0509B	
2020-K16	20	20	125	25	20	20	TN_1604_	LV3	SP3	LSPS3	HW25L	VHX0617	ST317
2020-K16N	20	20	125	25	20	20		LV3N	SP3N	LSPS3	HW25L	VHX0617N	ST317N
2525-M11	25	25	150	32	25	20	TN_1103_	LV2			HW20L	VHX0509B	
2525-M16	25	25	150	32	25	20	TN_1604_	LV3	SP3	LSPS3	HW25L	VHX0617	ST317
2525-M16N	25	25	150	32	25	20		LV3N	SP3N	LSPS3	HW25L	VHX0617N	ST317N
2525-M22	25	25	150	32	25	28	TN_2204_	LV4	SP4	LSPS4	HW30L	VHX0821	ST42
2525-M22N	25	25	150	32	25	28		LV4N	SP4N	LSPS4	HW30L	VHX0820N	ST42N
2525-R22	25	25	200	32	25	28		LV4	SP4	LSPS4	HW30L	VHX0821	ST42
3232-P16	32	32	170	40	32	20	TN_1604_	LV3	SP3	LSPS3	HW25L	VHX0617	ST317
3232-P16N	32	32	170	40	32	20		LV3N	SP3N	LSPS3	HW25L	VHX0617N	ST317N
3232-P22	32	32	170	40	32	28	TN_2204_	LV4	SP4	LSPS4	HW30L	VHX0821	ST42
3232-P22N	32	32	170	40	32	28		LV4N	SP4N	LSPS4	HW30L	VHX0820N	ST42N
3232-P27	32	32	170	40	32	33	TN_2706_	LV5	SP5	LSPS5	HW30L	VHX0825	T53
3232-P27N	32	32	170	40	32	33		LV5AN	SP5N	LSPS5	HW30L	VHX0823N	ST53N
4040-S27	40	40	250	50	40	33		LV5	SP5	LSPS5	HW30L	VHX0825	T53
4040-S27N	40	40	250	50	40	33		LV5AN	SP5N	LSPS5	HW30L	VHX0823N	ST53N

PTTNR/L

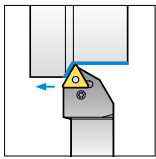

60°

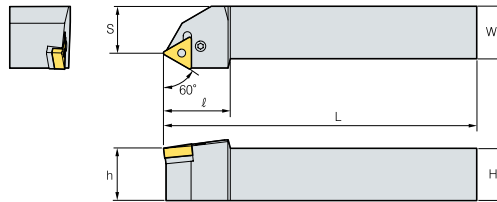

WSP



TN_

(mm)

Bezeichnung	H	W	L	S	h	ℓ	WSP	Kniehebel	Rohrstift	Rohrstift-Dorn	Schlüssel	Schraube	Zwischenlage
PTTNR/L 1616-H16	16	16	100	13	16	25	TN_1604_	LV3	SP3	LSPS3	HW25L	VHX0617	ST317
1616-H16N	16	16	100	13	16	25		LV3N	SP3N	LSPS3	HW25L	VHX0617N	ST317N
2020-K16	20	20	125	17	20	25		LV3	SP3	LSPS3	HW25L	VHX0617	ST317
2020-K16N	20	20	125	17	20	25		LV3N	SP3N	LSPS3	HW25L	VHX0617N	ST317N
2525-K16	25	25	125	22	25	32		LV3	SP3	LSPS3	HW25L	VHX0617	ST317
2525-M16	25	25	150	22	25	32		LV3	SP3	LSPS3	HW25L	VHX0617	ST317
2525-M16N	25	25	150	22	25	32		LV3N	SP3N	LSPS3	HW25L	VHX0617N	ST317N
2525-M22	25	25	150	22	25	32	TN_2204_	LV4	SP4	LSPS4	HW30L	VHX0821	ST42
2525-M22N	25	25	150	22	25	32		LV4N	SP4N	LSPS4	HW30L	VHX0820N	ST42N



PWLNR/L

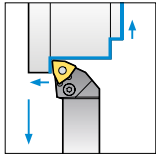

95°

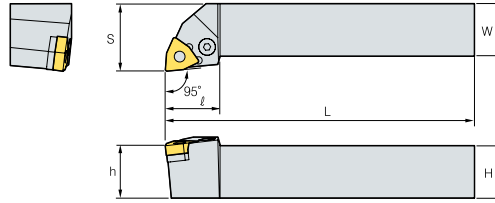

WSP



WN_

(mm)

Bezeichnung	H	W	L	S	h	ℓ	WSP	Kniehebel	Rohrstift	Rohrstift-Dorn	Schlüssel	Schraube	Zwischenlage
PWLNR/L 1616-H06	16	16	100	20	16	20	WN_0604_	LV3	SP3	LSPS3	HW25L	VHX0617	SW317
1616-H06N	16	16	100	20	16	20		LV3N	SP3N	LSPS3	HW25L	VHX0617N	SW317N
2020-K06	20	20	125	25	20	20		LV3	SP3	LSPS3	HW25L	VHX0617	SW317
2020-K06N	20	20	125	25	20	20		LV3N	SP3N	LSPS3	HW25L	VHX0617N	SW317N
2020-K08	20	20	125	25	20	26	WN_0804_	LV4	SP4	LSPS4	HW30L	VHX0821	SW42
2020-K08N	20	20	125	25	20	26		LV4N	SP4N	LSPS4	HW30L	VHX0820N	SW42N
2525-M06	25	25	150	32	25	20	WN_0604_	LV3	SP3	LSPS3	HW25L	VHX0617	SW317
2525-M06N	25	25	150	32	25	20		LV3N	SP3N	LSPS3	HW25L	VHX0617N	SW317N
2525-M08	25	25	150	32	25	26	WN_0804_	LV4	SP4	LSPS4	HW30L	VHX0821	SW42
2525-M08N	25	25	150	32	25	26		LV4N	SP4N	LSPS4	HW30L	VHX0820N	SW42N
3232-M08	32	32	150	40	32	33		LV4	SP4	LSPS4	HW30L	VHX0821	SW42
3232-P08	32	32	170	40	32	33		LV4	SP4	LSPS4	HW30L	VHX0821	SW42



WTENN

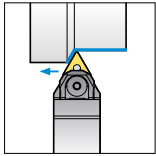

60°

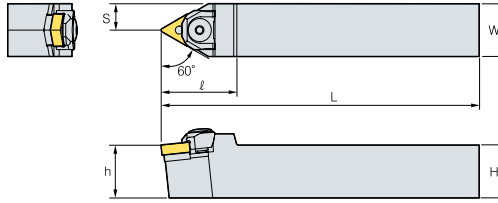

WSP



TN_

(mm)

Bezeichnung	H	W	L	S	h	ℓ	WSP	Keilklemme	Mutter	Rohrstift	Schlüssel	Schraube	Sicherungsring	Zwischenlage	
WTENN	2020-K16	20	20	125	10	20	36	TN_1604_	CMH6R6	N0407	SP3M-1	HW30L	MHX0626	ER04	ST32M
	2525-M16	25	25	150	12,5	25	36		CMH6R6	N0407	SP3M	HW30L	MHX0626	ER04	ST32M
	2525-M22	25	25	150	12,5	25	42	TN_2204_	CMH6R1	N0508	SP4M	HW30L	MHX0626	ER04	ST43M
	3232-P22	32	32	170	16	32	42		CMH6R1	N0508	SP4M	HW30L	MHX0626	ER04	ST43M

WTJNR/L

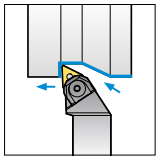

93°

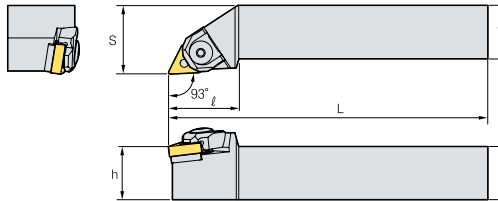

WSP



TN_

(mm)

Bezeichnung	H	W	L	S	h	ℓ	WSP	Keilklemme	Mutter	Rohrstift	Schlüssel	Schraube	Sicherungsring	Zwischenlage	
WTJNR/L	2020-K16	20	20	125	25	20	33	TN_1604_	CMH6R6	N0407	SP3M-1	HW30L	MHX0626	ER04	ST32M
	2020-M16	20	20	150	25	20	33		CMH6R6	N0407	SP3M	HW30L	MHX0626	ER04	ST32M
	2525-M16	25	25	150	32	25	33		CMH6R6	N0407	SP3M	HW30L	MHX0626	ER04	ST32M
	2525-M22	25	25	150	32	25	35	TN_2204_	CMH6R1	N0508	SP4M	HW30L	MHX0626	ER04	ST43M
	2525-P22	25	25	170	32	25	35		CMH6R1	N0508	SP4M	HW30L	MHX0626	ER04	ST43M
	3225-P16	32	25	170	40	32	33	TN_1604_	CMH6R6	N0407	SP3M	HW30L	MHX0626	ER04	ST32M
	3232-P16	32	32	170	40	32	33		CMH6R6	N0407	SP3M	HW30L	MHX0626	ER04	ST32M
	3232-P22	32	32	170	40	32	35	TN_2204_	CMH6R1	N0508	SP4M	HW30L	MHX0626	ER04	ST43M

WTXNR/L

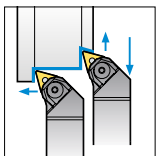

105°

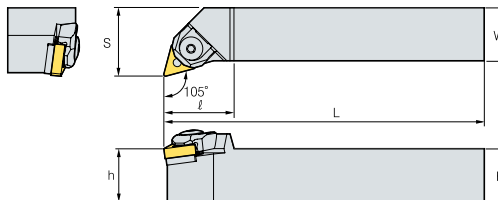

WSP



TN_

(mm)

Bezeichnung	H	W	L	S	h	ℓ	WSP	Keilklemme	Mutter	Rohrstift	Schlüssel	Schraube	Sicherungsring	Zwischenlage	
WTXNR/L	2020-K16	20	20	125	25	20	30	TN_1604_	CMH6R6	N0407	SP3M-1	HW25L HW30L	MHX0626	ER04	ST32M
	2525-M16	25	25	150	32	25	33		CMH6R6	N0407	SP3M	HW25L HW30L	MHX0626	ER04	ST32M
	3232-P16	32	32	170	40	32	33		CMH6R6	N0407	SP3M	HW25L HW30L	MHX0626	ER04	ST32M



WWLNR/L

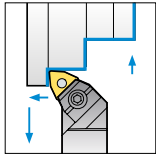

95°

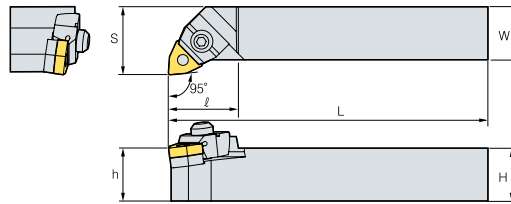

WSP



WN_

(mm)

Bezeichnung	H	W	L	S	h	ℓ	WSP	C-Ring	Keilklemme	Mutter	Rohrstift	Schlüssel	Schraube	Zwischenlage
WWLNR/L 2020-K08	20	20	125	25	20	32	WN_0804_							
2525-M08	25	25	150	32	25	33		CR05	CMH6R/L3	N0508	SP2M	HW30L HW40L	MHX0630	SW43M
3225-M08	32	25	150	40	32	33		CR05	CMH6R2	N0508	SP4M	HW30L HW40L	MHX0630	SW43M
3232-P08	32	32	170	40	32	33		CR05	CMH6R2	N0508	SP4M	HW30L HW40L	MHX0630	SW43M



CKJNR/L

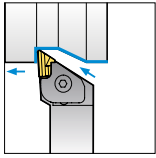

93°

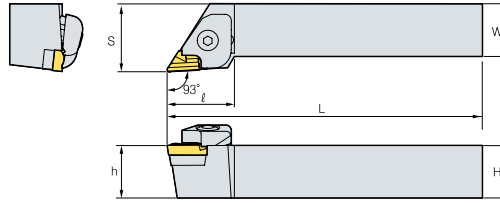

WSP



KN_

(mm)

Bezeichnung	H	W	L	S	h	ℓ	WSP	Feder	Klemme	Klemmschraube	Lagenschraube	Schlüssel	Stift	Zwischenlage
CKJNL 2020-K16	20	20	125	25	20	32	KN_1604_L	SR3 SR4	CTH6L1	CHX0625	SHX0310	HW20L HW40L	PN0515	SK33CL
	25	25	150	32	25	32		SR3 SR4	CTH6L1	CHX0625	SHX0310	HW20L HW40L	PN0515	SK33CL
	32	32	170	40	32	32		SR3 SR4	CTH6L1	CHX0625	SHX0310	HW20L HW40L	PN0515	SK33CL
	40	40	200	50	40	32		SR3 SR4	CTH6L1	CHX0625	SHX0310	HW20L HW40L	PN0515	SK33CL
CKJNR 2020-K16	20	20	125	25	20	32	KN_1604_R	SR3 SR4	CTH6R1	CHX0625	SHX0310	HW20L HW40L	PN0515	SK33C
	25	25	150	32	25	32		SR3 SR4	CTH6R1	CHX0625	SHX0310	HW20L HW40L	PN0515	SK33C
	32	25	150	32	32	32		SR3 SR4	CTH6R1	CHX0625	SHX0310	HW20L HW40L	PN0515	SK33C
	32	25	170	32	32	32		SR3 SR4	CTH6R1	CHX0625	SHX0310	HW20L HW40L	PN0515	SK33C
	32	32	170	40	32	32		SR3 SR4	CTH6R1	CHX0625	SHX0310	HW20L HW40L	PN0515	SK33C
	40	40	200	50	40	32		SR3 SR4	CTH6R1	CHX0625	SHX0310	HW20L HW40L	PN0515	SK33C



CKNNR/L

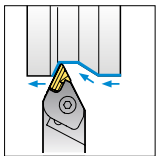

62,5°

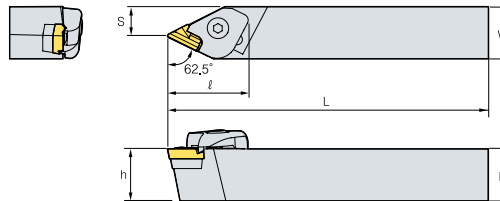

WSP



KN_

(mm)

Bezeichnung	H	W	L	S	h	ℓ	WSP	Feder	Klemme	Klemmschraube	Lagenschraube	Schlüssel	Stift	Zwischenlage
CKNNL 2525-M16	25	25	150	14,3	25	37	KN_1604_L	SR3 SR4	CTH6L1	CHX0625	SHX0310	HW20L HW40L	PN0515	SK33CL
	32	32	170	16,8	32	37		SR3 SR4	CTH6L1	CHX0625	SHX0310	HW20L HW40L	PN0515	SK33CL
CKNNR 2525-M16	25	25	150	14,3	25	37	KN_1604_R	SR3 SR4	CTH6R1	CHX0625	SHX0310	HW20L HW40L	PN0515	SK33C
	32	32	170	16,8	32	37		SR3 SR4	CTH6R1	CHX0625	SHX0310	HW20L HW40L	PN0515	SK33C



CSDPN

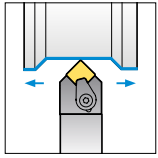

45°

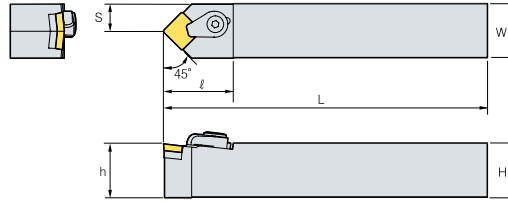

WSP

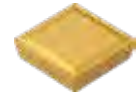

SP_R

Bezeichnung		H	W	L	S	h	ℓ	WSP	C-Ring	Klemme	Klemmschraube	Rohrstift	Schlüssel	Zwischenlage
CSDPN	1616-H09	16	16	100	8	16	30	SP_R0903_	CR03C	CH53R1	CH0515C	SP3C	HW25L	SS32C
	2525-M12	25	25	150	12,5	25	35	SP_R1203_	CR04C	CH6R5	CHX0622C	SP3C	HW25L	SS42C

(mm)

CSKPR/L

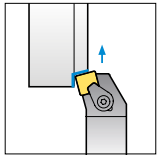

75°

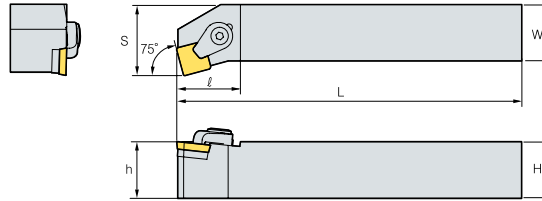

WSP

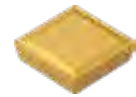

SP_R

Bezeichnung		H	W	L	S	h	ℓ	WSP	C-Ring	Klemme	Klemmschraube	Rohrstift	Schlüssel	Zwischenlage
CSKPR/L	2525-M12	25	25	150	32	20	32	SP_R1203_	CR04C	CH6R5	CHX0622C	SP3C	HW30L	SS42C

(mm)

CTFPR/L

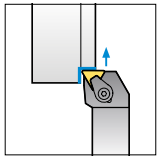

90°

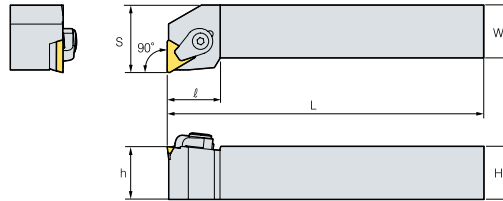

WSP



TP_R

Bezeichnung		H	W	L	S	h	ℓ	WSP	C-Ring	Klemme	Klemmschraube	Rohrstift	Schlüssel	Zwischenlage
CTFPR/L	2020-K16	20	20	125	25	20	32	TP_R1603_	CR04C	CH6R5	CHX0622C	SP3C	HW30L	ST32C
	2525-M16	25	25	150	32	25	32		CR04C	CH6R5	CHX0622C	SP3C	HW30L	ST32C

(mm)



CTGPR/L

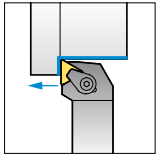

90°

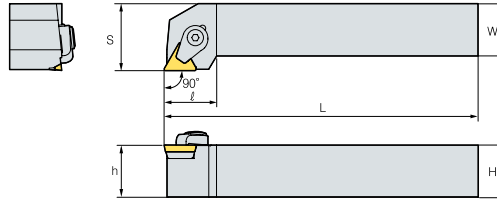

WSP



TP_R

(mm)

Bezeichnung		H	W	L	S	h	ℓ	WSP	C-Ring	Klemme	Klemmschraube	Rohrstift	Schlüssel	Zwischenlage
CTGPR/L	1212-F11	12	12	80	16	12	20	TP_R1103						
	1616-H11	16	16	100	20	16	20							
	2020-K11	20	20	125	25	20	20							
	2020-K16	20	20	125	25	20	25	TP_R1603						
	2525-M16	25	25	150	32	25	25							
	2525-M22	25	25	150	32	25	32	TP_R2204						
	3232-P22	32	32	170	40	32	32							



MCKNR/L

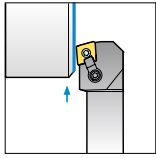

75°

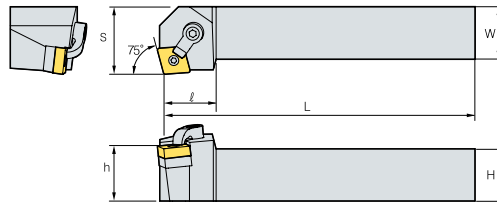

WSP



CN_

Bezeichnung		H	W	L	S	h	ℓ	WSP	Klemme	Klemmschraube	Rohrstift	Schlüssel	Zwischenlage
MCKNR/L	2020-K12	20	20	125	25	20	32	CN_1204_	CDH6N	DHA1/4-25	SP4D	HW23.8L HW31.8L	SC43D
	2525-M12	25	25	150	32	25	32		CDH6N	DHA1/4-25	SP4D	HW23.8L HW31.8L	SC43D
	3232-P12	32	32	170	40	32	32		CDH6N	DHA1/4-25	SP4D	HW23.8L HW31.8L	SC43D

(mm)

MCLNR/L

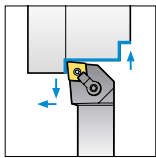

95°

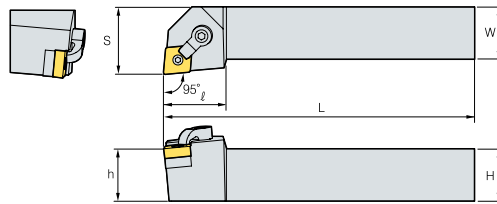

WSP



CN_

Bezeichnung		H	W	L	S	h	ℓ	WSP	Klemme	Klemmschraube	Rohrstift	Schlüssel	Zwischenlage
MCLNR/L	1616-H09	16	16	100	20	16	25	CN_0903_	CDH7N	DHA10-32-19	SP3DS	HW19.8L HW23.8L	SC32D
	2020-K09	20	20	125	25	20	25		CDH7N	DHA10-32-19	SP3DS	HW19.8L HW23.8L	SC32D
	2020-K12	20	20	125	25	20	32	CN_1204_	CDH6N	DHA1/4-25	SP4D	HW23.8L HW31.8L	SC43D
	2525-M09	25	25	150	32	25	25	CN_0903_	CDH7N	DHA10-32-19	SP3DS	HW19.8L HW23.8L	SC32D
	2525-M12	25	25	150	32	25	32	CN_1204_	CDH6N	DHA1/4-25	SP4D	HW23.8L HW31.8L	SC43D
	2525-M16	25	25	150	32	25	33	CN_1606_	CDH8N	DHA5/16-32	SP5D	HW31.8L HW39.7L	SC53D
	2525-M19	25	25	150	32	25	38	CN_1906_	CDH8N	DHA5/16-32	SP6D	HW35.7L HW39.7L	SC63D
	3225-P12	32	25	170	32	32	32	CN_1204_	CDH6N	DHA1/4-25	SP4D	HW23.8L HW31.8L	SC43D
	3232-P12	32	32	170	40	32	32		CDH6N	DHA1/4-25	SP4D	HW23.8L HW31.8L	SC43D
	3232-P16	32	32	170	40	32	33	CN_1606_	CDH8N	DHA5/16-32	SP5D	HW31.8L HW39.7L	SC53D
	3232-P19	32	32	170	40	32	38	CN_1906_	CDH8N	DHA5/16-32	SP6D	HW35.7L HW39.7L	SC63D
	4040-S16	40	40	250	50	40	33	CN_1606_	CDH8N	DHA5/16-32	SP5D	HW31.8L HW39.7L	SC53D
	4040-S19	40	40	250	50	40	38	CN_1906_	CDH8N	DHA5/16-32	SP6D	HW35.7L HW39.7L	SC63D
	4040-S25	40	40	250	50	40	38	CN_2507_	CDH8N3	DHA3/8-35	SP8D	HW39.7L HW47.6L	SC84D

(mm)



MCMNN

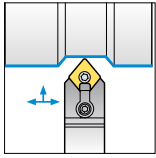

50°

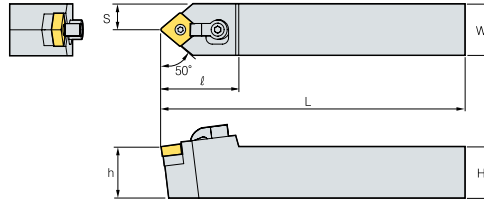

WSP



CN_

Bezeichnung		H	W	L	S	h	ℓ	WSP	Klemme	Klemmschraube	Rohrstift	Schlüssel	Zwischenlage
MCMNN	2020-K12	20	20	125	10	20	32	CN_1204_	CDH6N	DHA1/4-25	SP4D	HW23.8L HW31.8L	SC43D
	2525-M12	25	25	150	12,5	25	32		CDH6N	DHA1/4-25	SP4D	HW23.8L HW31.8L	SC43D
	2525-M16	25	25	150	12,5	25	40	CN_1606_	CDH8N	DHA5/16-32	SP5D	HW31.8L HW39.7L	SC53S
	3232-P12	32	32	170	16	32	32	CN_1204_	CDH6N	DHA1/4-25	SP4D	HW23.8L HW31.8L	SC43D
	3232-P16	32	32	170	16	32	40	CN_1606_	CDH8N	DHA5/16-32	SP5D	HW31.8L HW39.7L	SC53S
	3232-P19	32	32	170	16	32	40	CN_1906_	CDH8N	DHA5/16-32	SP6D	HW35.7L HW39.7L	SD63D
	4040-S19	40	40	250	20	40	32		CDH8N	DHA5/16-32	SP6D	HW35.7L HW39.7L	SD63D

(mm)

MCRNR/L

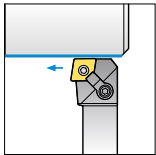

75°

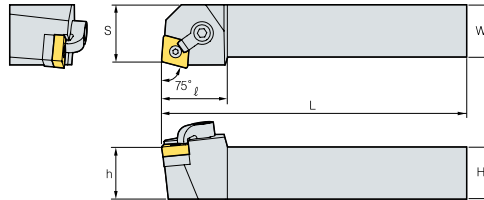

WSP



CN_

Bezeichnung		H	W	L	S	h	ℓ	WSP	Klemme	Klemmschraube	Rohrstift	Schlüssel	Zwischenlage
MCRNR/L	2020-K12	20	20	125	22	20	32	CN_1204_	CDH8N1	DHA5/16-32	SP4D	HW23.8L HW39.7L	SC43D
	2525-M12	25	25	150	27	25	32		CDH8N1	DHA5/16-32	SP4D	HW23.8L HW39.7L	SC43D
	2525-M16	25	25	150	27	25	33	CN_1606_	CDH8N1	DHA5/16-32	SP5D	HW31.8L HW39.7L	SC53D
	3232-P16	32	32	170	35	32	33	CN_1906_	CDH8N1	DHA5/16-32	SP5D	HW31.8L HW39.7L	SC53D
	3232-P19	32	32	170	35	32	38		CDH8N1	DHA5/16-32	SP6D	HW35.7L HW39.7L	SC63D
	3232-R19	32	32	200	35	32	38	CDH8N1	DHA5/16-32	SP6D	HW39.7L	SC63D	
	4040-S19	40	40	250	43	40	38	CDH8N1	DHA5/16-32	SP6D	HW35.7L HW39.7L	SC63D	

(mm)



MDJNR/L

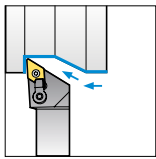

93°

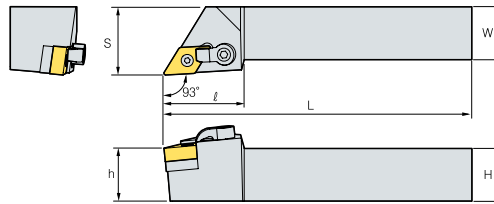

WSP



DN_

Bezeichnung		H	W	L	S	h	ℓ	WSP	Klemme	Klemmschraube	Rohrstift	Schlüssel	Zwischenlage
MDJNR/L	2020-K11	20	20	125	25	20	32	DN_1104_	CDH6N	DHA1/4-19	SP3D	HW19.8L HW31.8L	SD32D
	2020-K15	20	20	125	25	20	36	DN_1506_	CDH6N	DHA1/4-25	SP4DL	HW23.8L HW31.8L	SD43D
	2020-K15-3	20	20	125	25	20	36	DN_1504_	CDH6N	DHA1/4-25	SP4D	HW23.8L HW31.8L	SD43D
	2525-M11	25	25	150	32	25	32	DN_1104_	CDH6N	DHA1/4-19	SP3D	HW19.8L HW31.8L	SD32D
	2525-M15	25	25	150	32	25	36	DN_1506_	CDH6N	DHA1/4-25	SP4DL	HW23.8L HW31.8L	SD43D
	2525-M15-3	25	25	150	32	25	36	DN_1504_	CDH6N	DHA1/4-25	SP4D	HW23.8L HW31.8L	SD43D
	3232-P15	32	32	170	40	32	36	DN_1506_	CDH6N	DHA1/4-25	SP4DL	HW23.8L HW31.8L	SD43D
	3232-P15-3	32	32	170	40	32	36	DN_1504_	CDH6N	DHA1/4-25	SP4D	HW23.8L HW31.8L	SD43D

(mm)

MDNNN

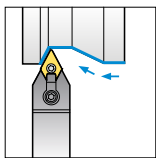

62,5°

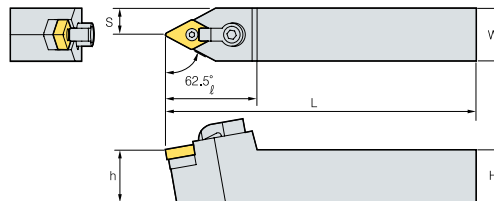

WSP



DN_

Bezeichnung		H	W	L	S	h	ℓ	WSP	Klemme	Klemmschraube	Rohrstift	Schlüssel	Zwischenlage
MDNNN	2525-M15	25	25	150	12,5	25	41	DN_1506_	CDH8N	DHA5/16-32	SP4DL	HW23.8L HW39.7L	SD43D
	2525-M15-3	25	25	150	12,5	25	41	DN_1504_	CDH8N	DHA5/16-32	SP4D	HW23.8L HW39.7L	SD43D

(mm)



MDQNR/L

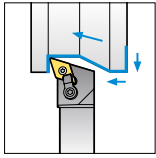

107,5°

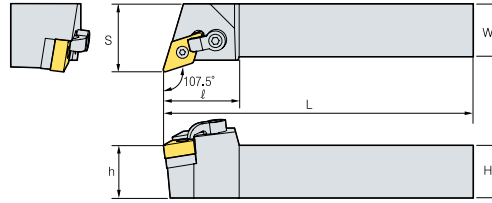

WSP



DN_

Bezeichnung		H	W	L	S	h	ℓ	WSP	Klemme	Klemmschraube	Rohrstift	Schlüssel	Zwischenlage
MDQNR/L	2525-M15	25	25	150	32	25	36	DN_1506_	CDH6N	DHA1/4-25	SP4DL	HW23.8L HW31.8L	SD43D
	2525-M15-3	25	25	150	32	25	36	DN_1504_	CDH6N	DHA1/4-25	SP4D	HW23.8L HW31.8L	SD43D
	3232-M15	32	32	170	40	32	36	DN_1506_	CDH6N	DHA1/4-25	SP4DL	HW23.8L HW31.8L	SD43D
	3232-P15	32	32	170	40	32	36		CDH6N	DHA1/4-25	SP4DL	HW23.8L HW31.8L	SD43D
	3232-P15-3	32	32	170	40	32	36	DN_1504_	CDH6N	DHA1/4-25	SP4D	HW23.8L HW31.8L	SD43D

(mm)

MSBNR/L

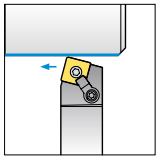

75°

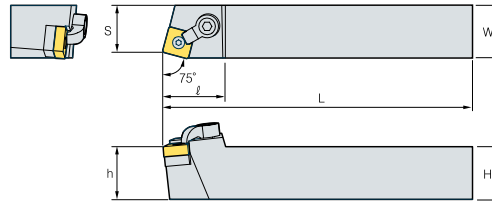

WSP



SN_

Bezeichnung		H	W	L	S	h	ℓ	WSP	Klemme	Klemmschraube	Rohrstift	Schlüssel	Zwischenlage
MSBNR/L	2020-K12	20	20	125	17	20	32	SN_1204_	CDH8N1	DHA5/16-32	SP4D	HW23.8L HW39.7L	SS43D
	2525-M12	25	25	150	22	25	32		CDH8N1	DHA5/16-32	SP4D	HW23.8L HW39.7L	SS43D
	2525-M15	25	25	150	22	25	35	SN_1506_	CDH8N	DHA5/16-32	SP5D	HW31.8L HW39.7L	SS53D
	3232-P15	32	32	170	22	32	35		CDH8N	DHA5/16-32	SP5D	HW31.8L HW39.7L	SS53D
	3232-P19	32	32	170	27	32	40	SN_1906_	CDH8N	DHA5/16-32	SP6D	HW35.7L HW39.7L	SS63D
	4040-S19	40	40	250	35	40	40		CDH8N	DHA5/16-32	SP6D	HW35.7L HW39.7L	SS63D

(mm)



MSDNN

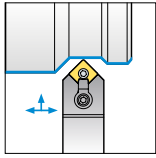

45°

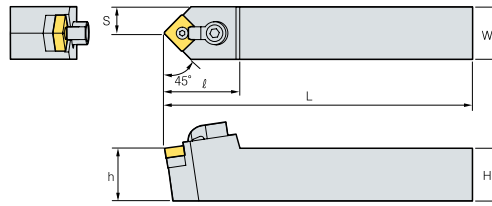

WSP



SN_

(mm)

Bezeichnung		H	W	L	S	h	ℓ	WSP	Klemme	Klemmschraube	Rohrstift	Schlüssel	Zwischenlage
MSDNN	1616-H09	16	16	100	8	16	28	SN_0903_	CDH7N	DHA10-32-19	SP3DS	HW19.8L HW23.8L	SS32D
	2020-K09	20	20	125	10	20	28		CDH7N	DHA10-32-19	SP3DS	HW19.8L HW23.8L	SS32D
	2020-K12	20	20	125	10	20	32	SN_1204_	CDH8N1	DHA5/16-32	SP4D	HW23.8L HW39.7L	SS43D
	2525-M12	25	25	150	12,5	25	32		CDH8N1	DHA5/16-32	SP4D	HW23.8L HW39.7L	SS43D
	2525-M15	25	25	150	12,5	25	35	SN_1506_	CDH8N	DHA5/16-32	SP5D	HW31.8L HW39.7L	SS53D
	3225-P12	32	25	170	12,5	32	32	SN_1204_	CDH8N1	DHA5/16-32	SP4D	HW23.8L HW39.7L	SS43D
	3225-P15	32	25	170	12,5	32	35	SN_1506_	CDH8N	DHA5/16-32	SP5D	HW31.8L HW39.7L	SS53D
	3232-P15	32	32	170	16	32	35		CDH8N	DHA5/16-32	SP5D	HW31.8L HW39.7L	SS53D
	3232-P19	32	32	170	16	32	42	SN_1906_	CDH8N	DHA5/16-32	SP6D	HW35.7L HW39.7L	SS63D
	4040-S15	40	40	250	20	40	35	SN_1506_	CDH8N	DHA5/16-32	SP5D	HW31.8L HW39.7L	SS53D
4040-S19	40	40	250	20	40	42	SN_1906_	CDH8N	DHA5/16-32	SP6D	HW35.7L HW39.7L	SS63D	

MSKNR/L

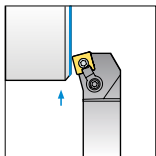

75°

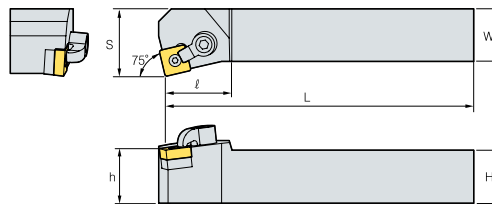

WSP



SN_

(mm)

Bezeichnung		H	W	L	S	h	ℓ	WSP	Klemme	Klemmschraube	Rohrstift	Schlüssel	Zwischenlage
MSKNR/L	1616-H09	16	16	100	20	16	28	SN_0903_	CDH7N	DHA10-32-19	SP3DS	HW19.8L HW23.8L	SS32D
	2020-K09	20	20	125	22	20	28		CDH7N	DHA10-32-19	SP3DS	HW19.8L HW23.8L	SS32D
	2020-K12	20	20	125	25	20	32	SN_1204_	CDH8N1	DHA5/16-32	SP4D	HW23.8L HW39.7L	SS43D
	2525-M12	25	25	150	32	25	32		CDH8N1	DHA5/16-32	SP4D	HW23.8L HW39.7L	SS43D
	2525-M15	25	25	150	32	25	35	SN_1506_	CDH8N	DHA5/16-32	SP5D	HW31.8L HW39.7L	SS53D
	3225-P12	32	25	170	32	32	32	SN_1204_	CDH8N1	DHA5/16-32	SP4D	HW23.8L HW39.7L	SS43D
	3232-P15	32	32	170	40	32	35	SN_1506_	CDH8N	DHA5/16-32	SP5D	HW31.8L HW39.7L	SS53D
	3232-P19	32	32	170	40	32	40	SN_1906_	CDH8N	DHA5/16-32	SP6D	HW35.7L HW39.7L	SS63D
	4040-S19	40	40	250	50	40	40		CDH8N	DHA5/16-32	SP6D	HW35.7L HW39.7L	SS63D
	4040-S25	40	40	250	50	40	47	SN_2507_	CDH8N3	DHA3/8-35	SP8D	HW39.7L HW47.6L	SS84D



MSRNR/L

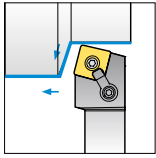

75°

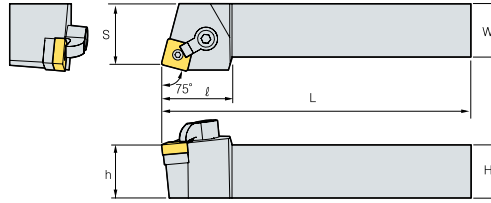

WSP



SN_

Bezeichnung		H	W	L	S	h	ℓ	WSP	Klemme	Klemmschraube	Rohrstift	Schlüssel	Zwischenlage
MSRNR/L	1616-H09	16	16	100	17	16	28	SN_0903_	CDH7N	DHA10-32-19	SP3DS	HW19.8L HW23.8L	SS32D
	2020-K09	20	20	125	22	20	28		CDH7N	DHA10-32-19	SP3DS	HW19.8L HW23.8L	SS32D
	2020-K12	20	20	125	22	20	32	SN_1204_	CDH8N1	DHA5/16-32	SP4D	HW23.8L HW39.7L	SS43D
	2525-M12	25	25	150	27	25	32		CDH8N1	DHA5/16-32	SP4D	HW23.8L HW39.7L	SS43D
	2525-M15	25	25	150	27	25	35	SN_1506_	CDH8N	DHA5/16-32	SP5D	HW31.8L HW39.7L	SS53D
	3225-P19	32	25	170	27	32	40	SN_1906_	CDH8N	DHA5/16-32	SP5D	HW31.8L HW39.7L	SS53D
	3232-P15	32	32	170	35	32	35	SN_1506_	CDH8N	DHA5/16-32	SP5D	HW31.8L HW39.7L	SS53D
	3232-P19	32	32	170	35	32	40	SN_1906_	CDH8N	DHA5/16-32	SP6D	HW35.7L HW39.7L	SS63D
	4040-S19	40	40	250	43	40	40		CDH8N	DHA5/16-32	SP6D	HW35.7L HW39.7L	SS63D
	4040-S25	40	40	250	43	40	40	SN_2507_	CDH8N3	DHA3/8-35	SP8D	HW39.7L HW47.6L	SS84D

(mm)



MSSNR/L

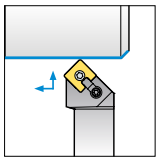

45°

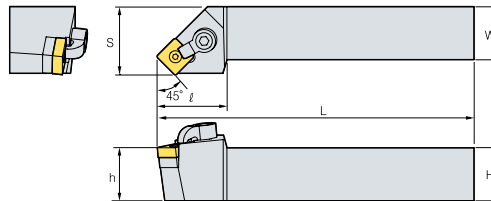

WSP



SN_

Bezeichnung		H	W	L	S	h	ℓ	WSP	Klemme	Klemmschraube	Rohrstift	Schlüssel	Zwischenlage
MSSNR/L	1616-H09	16	16	100	20	16	28	SN_0903_	CDH7N	DHA10-32-19	SP3DS	HW19.8L HW23.8L	SS32D
	2020-K09	20	20	125	25	20	28		CDH7N	DHA10-32-19	SP3DS	HW19.8L HW23.8L	SS32D
	2020-K12	20	20	125	25	20	32	SN_1204_	CDH8N1	DHA5/16-32	SP4D	HW23.8L HW39.7L	SS43D
	2525-M12	25	25	150	32	25	32		CDH8N1	DHA5/16-32	SP4D	HW23.8L HW39.7L	SS43D
	2525-M15	25	25	150	32	25	35	SN_1506_	CDH8N1	DHA5/16-32	SP5D	HW31.8L HW39.7L	SS53D
	3232-P15	32	32	170	40	32	35	SN_1906_	CDH8N1	DHA5/16-32	SP5D	HW31.8L HW39.7L	SS53D
	3232-P19	32	32	170	40	32	40		CDH8N1	DHA5/16-32	SP6D	HW35.7L HW39.7L	SS63D
	4040-S19	40	40	250	50	40	40	SN_1906_	CDH8N1	DHA5/16-32	SP6D	HW35.7L HW39.7L	SS63D
	4040-S25	40	40	250	50	40	48		SN_2507_	CDH8N3	DHA3/8-35	SP8D	HW39.7L HW47.6L

(mm)



MTENN

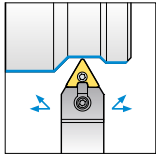

60°

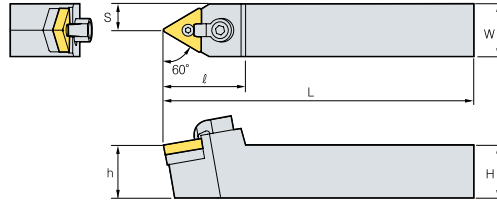

WSP



TN_

Bezeichnung		H	W	L	S	h	ℓ	WSP	Klemme	Klemmschraube	Rohrstift	Schlüssel	Zwischenlage
MTENN	2020-K16	20	20	125	10	20	32	TN_1604_	CDH7N	DHA10-32-19	SP3D	HW19.8L HW23.8L	ST32D
	2525-M16	25	25	150	12,5	25	32	TN_2204_	CDH7N	DHA10-32-19	SP3D	HW19.8L HW23.8L	ST32D
	2525-M22	25	25	150	12,5	25	35		CDH8N1	DHA5/16-32	SP4D	HW23.8L HW39.7L	ST43D
	3232-P27	32	32	170	16	32	35	TN_2706_	CDH8N1	DHA5/16-32	SP5D	HW31.8L HW39.7L	ST53D
	4040-S33	40	40	250	20	40	40	TN_3307_	CDH8N	DHA5/16-32	SP6DL	HW35.7L HW39.7L	ST63D

(mm)

MTFNR/L

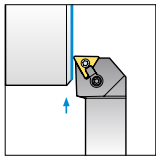

90°

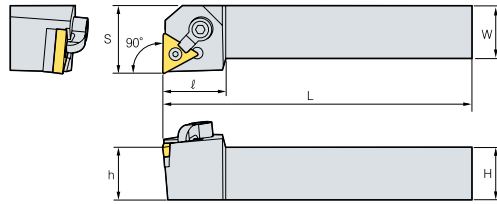

WSP



TN_

Bezeichnung		H	W	L	S	h	ℓ	WSP	Klemme	Klemmschraube	Rohrstift	Schlüssel	Zwischenlage
MTFNR/L	1616-H16	16	16	100	20	16	32	TN_1604_	CDH7N	DHA10-32-19	SP3D	HW19.8L HW23.8L	ST32D
	2020-K16	20	20	125	25	20	32		CDH7N	DHA10-32-19	SP3D	HW19.8L HW23.8L	ST32D
	2525-M16	25	25	150	32	25	32		CDH7N	DHA10-32-19	SP3D	HW19.8L HW23.8L	ST32D
	2525-M22	25	25	150	32	25	32	TN_2204_	CDH8N1	DHA5/16-32	SP4D	HW23.8L HW39.7L	ST43D
	3232-P22	32	32	170	40	32	32		CDH8N1	DHA5/16-32	SP4D	HW23.8L HW39.7L	ST43D
	3232-P27	32	32	170	40	32	35	TN_2706_	CDH8N1	DHA5/16-32	SP5D	HW31.8L HW39.7L	ST53D
	4040-S22	40	40	250	50	40	32	TN_2204_	CDH8N1	DHA5/16-32	SP4D	HW23.8L HW39.7L	ST43D
	4040-S27	40	40	250	50	40	35	TN_2706_	CDH8N1	DHA5/16-32	SP5D	HW31.8L HW39.7L	ST53D
	4040-S33	40	40	250	50	40	40	TN_3307_	CDH8N	DHA5/16-32	SP6DL	HW35.7L HW39.7L	ST63D

(mm)



MTGNR/L

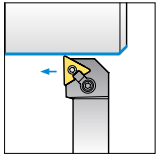

90°

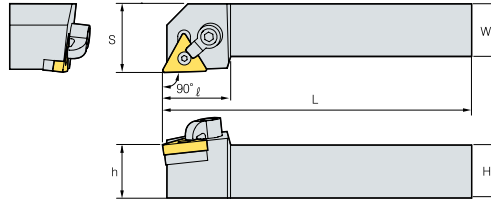

WSP



TN_

Bezeichnung		H	W	L	S	h	ℓ	WSP	Klemme	Klemmschraube	Rohrstift	Schlüssel	Zwischenlage
MTGNR/L	1616-H16	16	16	100	20	16	32	TN_1604_	CDH7N	DHA10-32-19	SP3D	HW19.8L HW23.8L	ST32D
	2020-K16	20	20	125	25	20	32		CDH7N	DHA10-32-19	SP3D	HW19.8L HW23.8L	ST32D
	2525-M16	25	25	150	32	25	32		CDH7N	DHA10-32-19	SP3D	HW19.8L HW23.8L	ST32D
	2525-M22	25	25	150	32	25	32	TN_2204_	CDH8N1	DHA5/16-32	SP4D	HW23.8L HW39.7L	ST43D
	3232-P22	32	32	170	40	32	32		CDH8N1	DHA5/16-32	SP4D	HW23.8L HW39.7L	ST43D
	3232-P27	32	32	170	40	32	35	TN_2706_	CDH8N1	DHA5/16-32	SP5D	HW31.8L HW39.7L	ST53D
	4040-S27	40	40	250	50	40	35		CDH8N1	DHA5/16-32	SP5D	HW31.8L HW39.7L	ST53D
	4040-S33	40	40	250	50	40	40	TN_3307_	CDH8N	DHA5/16-32	SP6DL	HW35.7L HW39.7L	ST63D

(mm)

MTJNR/L

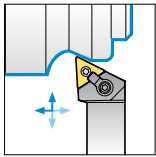

93°

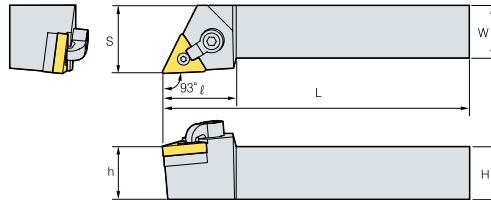

WSP



TN_

Bezeichnung		H	W	L	S	h	ℓ	WSP	Klemme	Klemmschraube	Rohrstift	Schlüssel	Zwischenlage
MTJNR/L	2020-K16	20	20	125	25	20	32	TN_1604_	CDH7N	DHA10-32-19	SP3D	HW19.8L HW23.8L	ST32D
	2525-M16	25	25	150	32	25	32		CDH7N	DHA10-32-19	SP3D	HW19.8L HW23.8L	ST32D
	2525-M22	25	25	150	32	25	32	TN_2204_	CDH8N1	DHA5/16-32	SP4D	HW23.8L HW39.7L	ST43D
	3232-P22	32	32	170	40	32	32		CDH8N1	DHA5/16-32	SP4D	HW23.8L HW39.7L	ST43D
	3232-P27	32	32	170	40	32	35	TN_2706_	CDH8N1	DHA5/16-32	SP5D	HW31.8L HW39.7L	ST53D
	4040-S27	40	40	250	50	40	35		CDH8N1	DHA5/16-32	SP5D	HW31.8L HW39.7L	ST53D
	4040-S33	40	40	250	50	40	40	TN_3307_	CDH8N	DHA5/16-32	SP6DL	HW35.7L HW39.7L	ST63D

(mm)



MVJNR/L

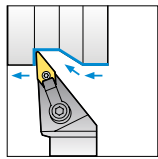

93°

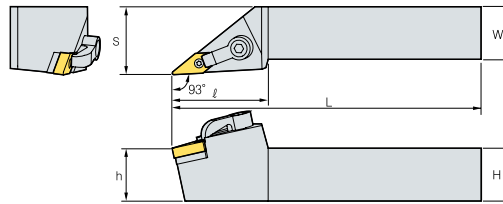

WSP



VN_

Bezeichnung		H	W	L	S	h	ℓ	WSP	Klemme	Klemmschraube	Rohrstift	Schlüssel	Zwischenlage
MVJNR/L	2020-K16	20	20	125	25	20	37	VN_1604_	CDH8N2	DHA5/16-32	SP3D	HW19.8L HW39.7L	SV32D
	2525-M16	25	25	150	32	25	37		CDH8N2	DHA5/16-32	SP3D	HW19.8L HW39.7L	SV32D
	2525-M22	25	25	150	32	25	50	VN_2204_	CDH8N2	DHA5/16-32	SP4D	HW23.8L HW39.7L	SV43D
	3232-P16	32	32	170	40	32	37	VN_1604_	CDH8N2	DHA5/16-32	SP3D	HW19.8L HW39.7L	SV32D
	3232-P22	32	32	170	40	32	50	VN_2204_	CDH8N2	DHA5/16-32	SP4D	HW23.8L HW39.7L	SV43D
	4040-S22	40	40	250	50	40	50		CDH8N2	DHA5/16-32	SP4D	HW23.8L HW39.7L	SV43D

(mm)

MVQNR/L

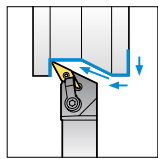

117,5°

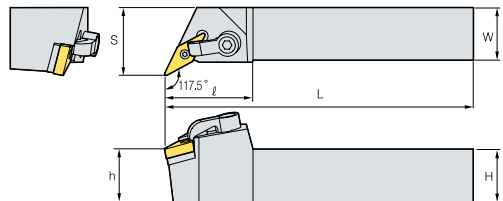

WSP



VN_

Bezeichnung		H	W	L	S	h	ℓ	WSP	Klemme	Klemmschraube	Rohrstift	Schlüssel	Zwischenlage
MVQNR/L	2020-K16	20	20	125	25	20	42	VN_1604_	CDH8N2	DHA5/16-32	SP3D	HW19.8L HW39.7L	SV32D
	2525-M16	25	25	150	32	25	42		CDH8N2	DHA5/16-32	SP3D	HW19.8L HW39.7L	SV32D
	3232-P16	32	32	170	40	32	37		CDH8N2	DHA5/16-32	SP3D	HW19.8L HW39.7L	SV32D

(mm)



MVVNN

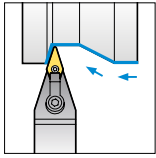

72,5°

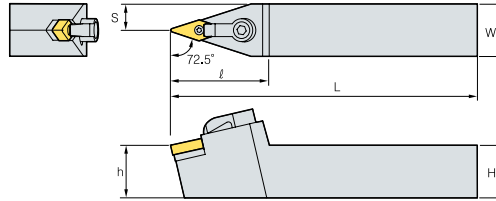

WSP



VN_

(mm)

Bezeichnung		H	W	L	S	h	ℓ	WSP	Klemme	Klemmschraube	Rohrstift	Schlüssel	Zwischenlage
MVVNN	2020-K16	20	20	125	25	20	42	VN_1604_	CDH8N2	DHA5/16-32	SP3D	HW19.8L HW39.7L	SV32D
	2525-M16	25	25	150	32	25	42		CDH8N2	DHA5/16-32	SP3D	HW19.8L HW39.7L	SV32D

MWLNR/L

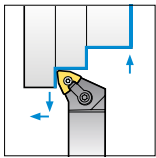

95°

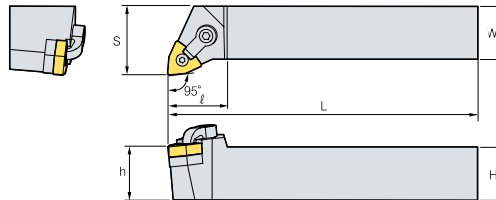

WSP



WN_

(mm)

Bezeichnung		H	W	L	S	h	ℓ	WSP	Klemme	Klemmschraube	Rohrstift	Schlüssel	Zwischenlage
MWLNR/L	2020-K06	20	20	125	25	20	32	WN_0604_	CDH7N	DHA10-32-19	SP3D	HW19.8L HW23.8L	SW32D
	2020-K08	20	20	125	25	20	32	WN_0804_	CDH6N	DHA1/4-21	SP4D	HW23.8L HW31.8L	SW43D
	2525-M06	25	25	150	32	25	32	WN_0604_	CDH7N	DHA10-32-19	SP3D	HW19.8L HW23.8L	SW32D
	2525-M08	25	25	150	32	25	32	WN_0804_	CDH6N	DHA1/4-21	SP4D	HW23.8L HW31.8L	SW43D
	3232-P06	32	32	170	40	32	32	WN_0604_	CDH7N	DHA10-32-19	SP3D	HW19.8L HW23.8L	SW32D
	3232-P08	32	32	170	40	32	32	WN_0804_	CDH6N	DHA1/4-21	SP4D	HW23.8L HW31.8L	SW43D
	3232-P13	32	32	170		32		WN_1306_	CDH8N	DHA5/16-32	SP6D	HW35.7L HW39.7L	SW63D
	4040-P13	40	40	170		40			CDH8N	DHA5/16-32	SP6D	HW35.7L HW39.7L	SW63D



SCACR/L

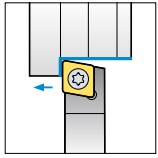

90°

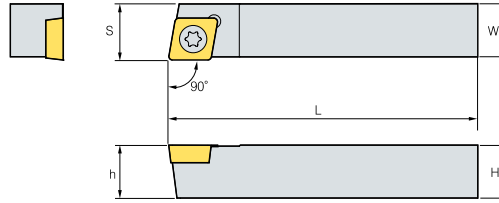

WSP



CC_

Bezeichnung		H	W	L	S	h	WSP	Schlüssel	Schraube
SCACR/L	1010-E06	10	10	70	10,5	10	CC__0602__	TW07P	FTKA02565
	1212-F09	12	12	80	12,5	12	CC__09T3__	TW15P	FTKA03508

(mm)

SCLCR/L

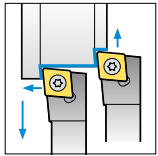

95°

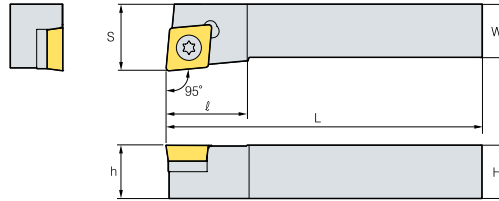

WSP



CC_

Bezeichnung		H	W	L	S	h	ℓ	WSP	Lagenschraube	Schlüssel	Schraube	Zwischenlage
SCLCR/L	0808-D06	8	8	60	10	8	10	CC__0602__	-	TW07P	FTKA02565	-
	1010-E06	10	10	70	16	10	10	CC__0602__	-	TW07P	FTKA02565	-
	1212-F09	12	12	80	20	12	16	CC__09T3__	-	TW15P	FTGA03508	-
	1616-H09	16	16	100	20	16	16	CC__09T3__	-	TW15P	FTGA03508	-
	2020-H09	20	20	100	25	20	16	CC__09T3__	-	TW15P	FTGA03508	-
	2020-K09	20	20	125	25	20	16	CC__09T3__	-	TW15P	FTGA03508	-
	2020-K12	20	20	125	25	20	25	CC__1204__	SHXN0610F	TW15P HW40L	FTGA0411F	SC42S
	2525-M09	25	25	150	32	25	26	CC__09T3__	-	TW15P	FTGA03508	-
	2525-M12	25	25	150	32	25	26	CC__1204__	SHXN0610F	TW15P HW40L	FTGA0411F	SC42S

(mm)



SDACR/L

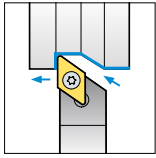

90°

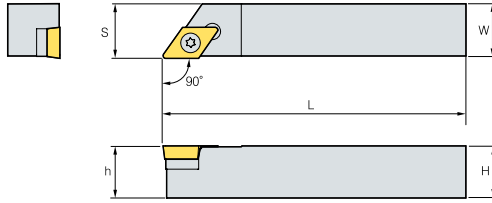

WSP

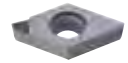

DC_

Bezeichnung		H	W	L	S	h	WSP	Lagenschraube	Schlüssel	Schraube	Zwischenlage
SDACR/L	1010-E07	10	10	70	10,5	10	DC__0702__	-	TW07P	FTKA02565	-
	1212-C11	12	12	50	12,5	12	DC__11T3__	SHXN0509F	TW15P HW35L	FTGA03512	SD32S
	1212-F11	12	12	80	12,5	12		-	TW15P	FTKA03508	-
	1212-M11	12	12	150	12,5	12		-	TW15P	FTKA03508	-
	1616-H11	16	16	100	16,5	16		SHXN0509F	TW15P HW35L	FTGA03512	SD32S
	2020-H11	20	20	100	20,5	20		SHXN0509F	TW15P HW35L	FTGA03512	SD32S
	2020-K11	20	20	125	20,5	20		SHXN0509F	TW15P HW35L	FTGA03512	SD32S

(mm)



SDJCR/L

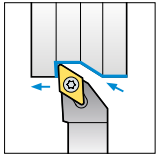

93°

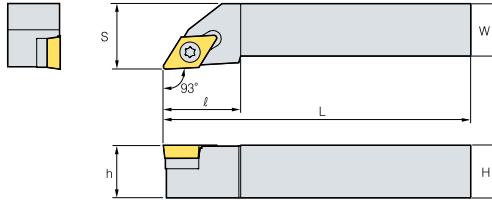

WSP



DC_

Bezeichnung		H	W	L	S	h	l	WSP	Lagenschraube	Schlüssel	Schraube	Zwischenlage
SDJCR/L	1010-E07	10	10	70	10	15	15	DC__0702__	-	TW07P	FTKA02565	-
	1010-F07	10	10	80	12	10	10		-	TW07P	FTKA02565	-
	1212-F07	12	12	80	12	15	15		-	TW07P	FTKA02565	-
	1212-F11	12	12	80	12	15	15	DC__11T3__	SHXN0509F	TW15P HW35L	FTGA03512	SD32S
	1212-M11	12	12	150	80	15	15		SHXN0509F	TW15P HW35L	FTGA03512	SD32S
	1616-H07	16	16	100	16	18	18	DC__0702__	-	TW07P	FTKA02565	-
	1616-H11	16	16	100	16	24	24	DC__11T3__	SHXN0509F	TW15P HW35L	FTGA03512	SD32S
	2020-K07	20	20	125	20	15	15	DC__0702__	-	TW07P	FTKA02565	-
	2020-K11	20	20	125	20	24	24	DC__11T3__	SHXN0509F	TW15P HW35L	FTGA03512	SD32S
	2525-M11	25	25	150	25	29	29		SHXN0509F	TW15P HW35L	FTGA03512	SD32S

(mm)



SDNCN

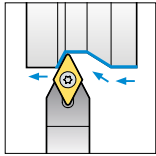

62,5°

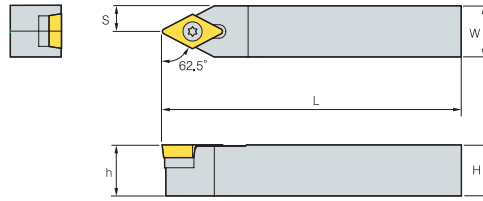

WSP



DC_

Bezeichnung		H	W	L	S	h	WSP	Lagenschraube	Schlüssel	Schraube	Zwischenlage
SDNCN	1010-E07	10	10	70	5	10	DC_0702_	-	TW07P	FTKA02565	-
	1212-F07	12	12	80	6	12		-	TW07P	FTKA02565	-
	1212-H11	12	12	100	6	12	DC_11T3_	-	TW15P	FTGA03508	-
	1212-M11	12	12	150	6	12		-	TW15P	FTGA03508	-
	1616-H11	16	16	100	8	16		SHXN0509F	TW15P HW35L	FTGA03512	SD32S
	2020-K11	20	20	125	10	20		SHXN0509F	TW15P HW35L	FTGA03512	SD32S
	2525-M11	25	25	150	12,5	25		SHXN0509F	TW15P HW35L	FTGA03512	SD32S

(mm)

SRDCN

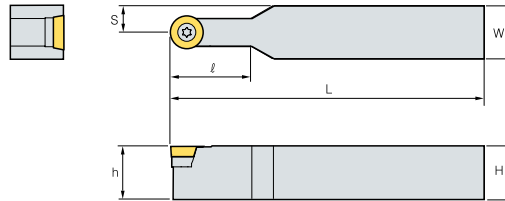
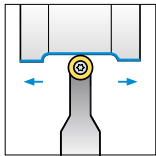

WSP



RCGT

Bezeichnung		H	W	L	S	h	l	WSP	Lagenschraube	Schlüssel	Schraube	Zwischenlage
SRDCN	1010-E06	10	10	70	5	10	10	RCGT0602M0	-	TW07P	FTKA02565	-
	1212-F06	12	12	80	6	12	12		-	TW07P	FTKA02565	-
	1616-H06	16	16	100	8	16	12		-	TW07P	FTKA02565	-
	1616-H08	16	16	100	8	16	16	RCGT0803M0	-	TW09P	FTNA0307	-
	1616-H10	16	16	100	8	16	25	RCGT1003M0	SHXN0509F	TW15P HW35L	FTKA03511A	SR10S
	2020-H10	20	20	100	10	20	25		SHXN0509F	TW15P HW35L	FTKA03511A	SR10S
	2020-K06	20	20	125	10	20	24	RCGT0602M0	-	TW07P	FTKA02565	-
	2020-K08	20	20	125	10	20	20	RCGT0803M0	-	TW09P	FTNA0307	-
	2020-K10	20	20	125	10	20	25	RCGT1003M0	SHXN0509F	TW15P HW35L	FTKA03511A	SR10S
	2020-K12	20	20	125	10	20	28	RCGT1204M0	SHXN0509F	TW15P HW35L	FTGA03512	SR12S
	2525-M06	25	25	150	12,5	25	20	RCGT0602M0	-	TW07P	FTKA02565	-
	2525-M08	25	25	150	12,5	25	20	RCGT0803M0	-	TW09P	FTNA0307	-
	2525-M10	25	25	150	12,5	25	25	RCGT1003M0	SHXN0509F	TW15P HW35L	FTKA03511A	SR10S
	2525-M12	25	25	150	12,5	25	28	RCGT1204M0	SHXN0509F	TW15P HW35L	FTGA03512	SR12S

(mm)



SRGCR/L

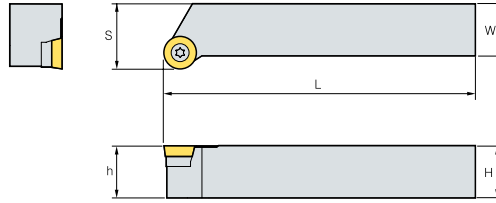
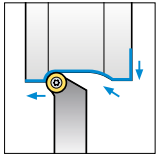

Bezeichnung		H	W	L	S	h	WSP	Lagenschraube	Schlüssel	Schraube	Zwischenlage
SRGCR/L	1010-E06	10	10	70	12	10	RCGT0602M0	-	TW07P	FTKA02565	-
	1212-F06	12	12	80	16	12		-	TW07P	FTKA02565	-
	1616-H06	16	16	100	20	16		-	TW07P	FTKA02565	-
	1616-H08	16	16	100	20	16	RCGT0803M0	-	TW09P	FTNA0307	-
	1616-H10	16	16	100	20	16	RCGT1003M0	SHXN0509F	TW15P HW35L	FTKA03511A	SR10S
	2020-K06	20	20	125	25	20	RCGT0602M0	-	TW07P	FTKA02565	-
	2020-K08	20	20	125	25	20	RCGT0803M0	-	TW09P	FTNA0307	-
	2020-K10	20	20	125	25	20	RCGT1003M0	SHXN0509F	TW15P HW35L	FTKA03511A	SR10S
	2020-K12	20	20	125	25	20	RCGT1204M0	SHXN0509F	TW15P HW35L	FTGA03512	SR12S
	2525-M06	25	25	150	32	25	RCGT0602M0	-	TW07P	FTKA02565	-
	2525-M08	25	25	150	32	25	RCGT0803M0	-	TW09P	FTNA0307	-
	2525-M10	25	25	150	32	25	RCGT1003M0	SHXN0509F	TW15P HW35L	FTKA03511A	SR10S
2525-M12	25	25	150	32	25	RCGT1204M0	SHXN0509F	TW15P HW35L	FTGA03512	SR12S	



SSBCR/L

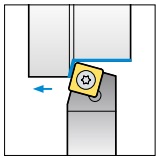

75°

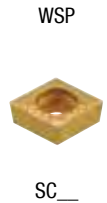
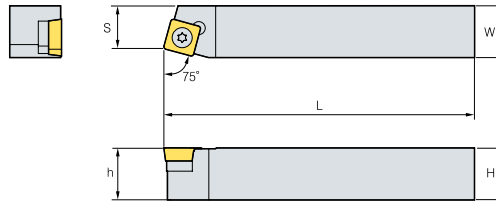

Bezeichnung		H	W	L	S	h	WSP	Lagenschraube	Schlüssel	Schraube	Zwischenlage
SSBCR/L	1212-F09	12	12	80	11	12	SC__09T3__	-	TW15P	FTGA03508	-
	1212-H09	12	12	100	11	12		SHXN0509F	TW15P HW35L	FTGA03512	SS32S
	1616-H09	16	16	100	13	16		SHXN0509F	TW15P HW35L	FTGA03512	SS32S
	2020-K12	20	20	125	17	20	SC__1204__	SHXN0610F	TW15P HW40L	FTGA0411F	SS42S



SSDCN

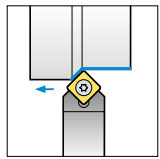

45°

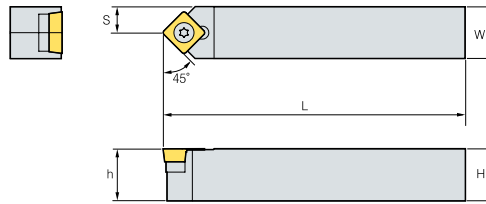

WSP

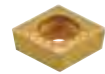

SC_

(mm)

Bezeichnung		H	W	L	S	h	WSP	Lagenschraube	Schlüssel	Schraube	Zwischenlage
SSDCN	1212-F09	12	12	80	6	12	SC_09T3_	-	TW15P	FTGA03508	-
	1616-H09	16	16	100	8	16		SHXN0509F	TW15P HW35L	FTGA03512	SS32S

SSKCR/L

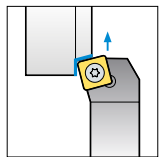

75°

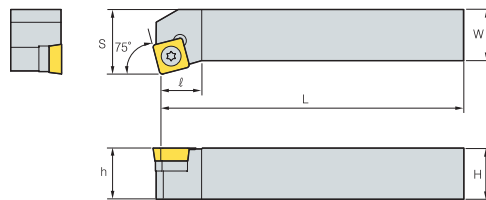

WSP

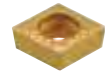

SC_

(mm)

Bezeichnung		H	W	L	S	h	ℓ	WSP	Lagenschraube	Schlüssel	Schraube	Zwischenlage
SSKCR/L	1616-H09	16	16	100	20	16	13	SC_09T3_	SHXN0509F	TW15P HW35L	FTGA03512	SS32S

SSSCR/L

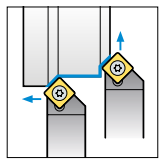

45°

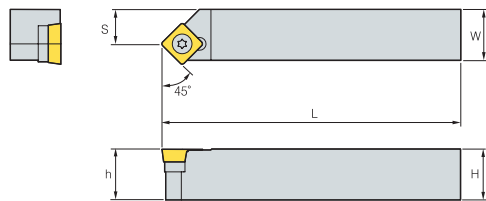

WSP

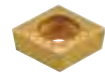

SC_

(mm)

Bezeichnung		H	W	L	S	h	WSP	Lagenschraube	Schlüssel	Schraube	Zwischenlage
SSSCR/L	1616-H09	16	16	100	17	16	SC_09T3_	SHXN0509F	TW15P HW35L	FTGA03512	SS32S
	2020-K09	20	20	125	25	20		SHXN0509F	TW15P HW35L	FTGA03512	SS32S
	2020-K12	20	20	125	21	20	SC_1204_	SHXN0610F	TW15P HW40L	FTGA0411F	SS42S
	2525-M12	25	25	150	26	25		SHXN0610F	TW15P HW35L	FTGA0411F	SS42S



STACR/L

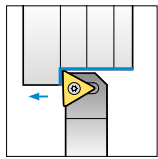

90°

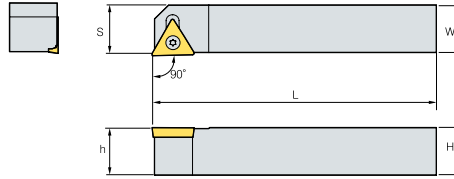

WSP



TC_

Bezeichnung		H	W	L	S	h	WSP	Schlüssel	Schraube
STACR/L	1010-E09	10	10	70	10,5	10	TC__0902__	TW06P	FTKA02206
	1212-F11	12	12	80	12,5	12	TC__1102__	TW07P	FTKA02565

(mm)

STFCR/L

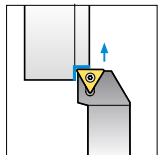

90°

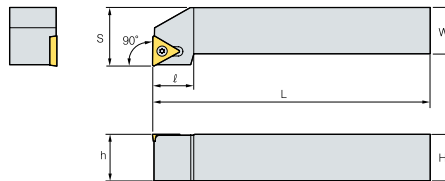

WSP



TC_

Bezeichnung		H	W	L	S	h	l	WSP	Lagenschraube	Schlüssel	Schraube	Zwischenlage
STFCR/L	1010-E09	10	10	70	12	10	10	TC__0902__	-	TW06P	FTKA02206	-
	1212-F11	12	12	80	16	12	14	TC__1102__	-	TW07P	FTKA02565	-
	1616-H11	16	16	100	20	16	14		-	TW07P	FTKA02565	-
	1616-H16	16	16	100	20	16	19	TC__16T3__	SHXN0509F	TW15P HW35L	FTGA03512	ST32S
	2020-K16	20	20	125	25	20	19		SHXN0509F	TW15P HW35L	FTGA03512	ST32S
	2525-M16	25	25	150	32	25	25		SHXN0509F	TW15P HW35L	FTGA03512	ST32S

(mm)



STGCR/L

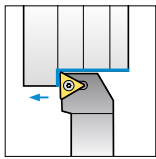

90°

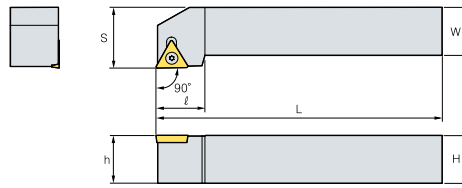

WSP



TC_

(mm)

Bezeichnung	H	W	L	S	h	ℓ	WSP	Lagenschraube	Schlüssel	Schraube	Zwischenlage
STGCR/L 0808-D09	8	8	60	10	8	11	TC__0902__	-	TW06P	FTKA02206	-
	1010-E09	10	10	70	12	10		-	TW06P	FTKA02206	-
1212-F11	12	12	80	16	12	14	TC__1102__	-	TW07P	FTKA02565	-
1616-H11	16	16	100	20	16	16	TC__16T3__	-	TW07P	FTKA02565	-
1616-H16	16	16	100	20	16	21		SHXN0509F	TW15P HW35L	FTGA03512	ST32S
2020-K16	20	20	125	25	20	21		SHXN0509F	TW15P HW35L	FTGA03512	ST32S
2525-M16	25	25	150	32	25	21		SHXN0509F	TW15P HW35L	FTGA03512	ST32S

STTCR/L

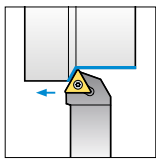

60°

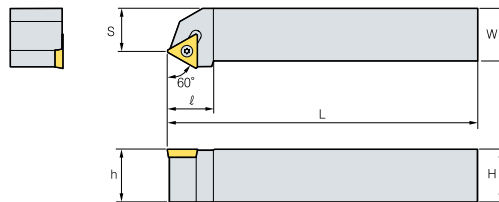

WSP



TC_

(mm)

Bezeichnung	H	W	L	S	h	ℓ	WSP	Lagenschraube	Schlüssel	Schraube	Zwischenlage
STTCR/L 1616-H11	16	16	100	13	16	14	TC__1102__	-	TW07P	FTKA02565	-
1616-H16	16	16	100	13	16	19	TC__16T3__	SHXN0509F	TW15P HW35L	FTGA03512	ST32S
2020-K16	20	20	125	17	20	19		SHXN0509F	TW15P HW35L	FTGA03512	ST32S
2525-M11	25	25	150	22	25	20	TC__1102__	-	TW07P	FTKA02565	-



SVABR/L

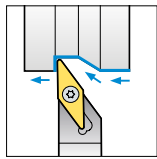

90°

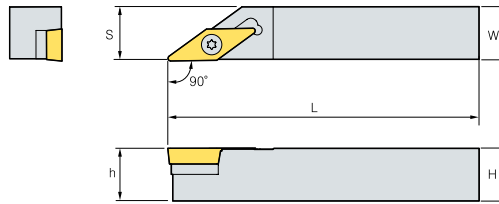

WSP



VB_

Bezeichnung		H	W	L	S	h	WSP	Lagenschraube	Schlüssel	Schraube	Zwischenlage
SVABR/L	1616-H16	16	16	100	16,5	16	VB__1604__	SHXN0509F	TW15P HW35L	FTGA03512	SV32S
	1616-K16	16	16	125	16,5	16		SHXN0509F	TW15P HW35L	FTGA03512	SV32S
	2020-K16	20	20	125	20,5	20		SHXN0509F	TW15P HW35L	FTGA03512	SV32S

SVHBR/L

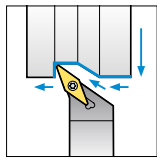

107,5°

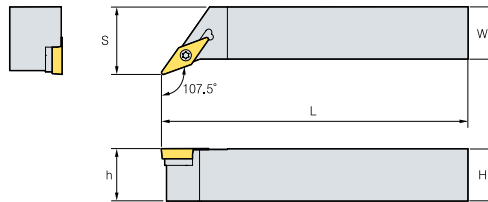

WSP



VB_

Bezeichnung		H	W	L	S	h	WSP	Lagenschraube	Schlüssel	Schraube	Zwischenlage
SVHBR/L	2020-K16	20	20	125	25	20	VB__1604__	SHXN0509F	TW15P HW35L	FTGA03512	SV32S
	2525-M16	25	25	150	32	25		SHXN0509F	TW15P HW35L	FTGA03512	SV32S
	3225-P16	32	25	170	32	32		SHXN0509F	TW15P HW35L	FTGA03512	SV32S



SVJBR/L

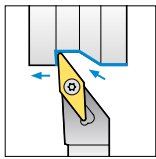

93°

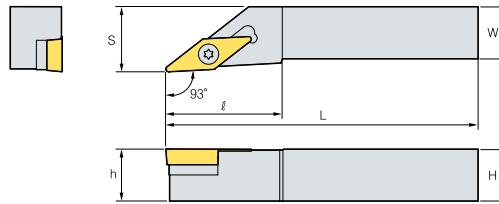

WSP



VB_

Bezeichnung		H	W	L	S	h	ℓ	WSP	Lagenschraube	Schlüssel	Schraube	Zwischenlage
SVJBR/L	1212-F11	12	12	80	16	12	27	VB_1102_	-	TW07P	FTKA02565	-
	1616-H11	16	16	100	20	16	27		-	TW07P	FTKA02565	-
	1616-H11-2	16	16	100	20	16	27	VB_1103_	-	TW07P	FTKA02565	-
	1616-H16	16	16	100	20	16	36	VB_1604_	SHXN0509F	TW15P HW35L	FTGA03512	SV32S
	2020-K11	20	20	125	25	20	27	VB_1102_	-	TW07P	FTKA02565	-
	2020-K11-2	20	20	125	25	20	27	VB_1103_	-	TW07P	FTKA02565	-
	2020-K16	20	20	125	25	20	41	VB_1604_	SHXN0509F	TW15P HW35L	FTGA03512	SV32S
	2525-M11	25	25	150	32	25	35	VB_1102_	-	TW07P	FTKA02565	-
	2525-M16	25	25	150	32	25	41	VB_1604_	SHXN0509F	TW15P HW35L	FTGA03512	SV32S
	3225-P16	32	25	170	32	32	55		SHXN0509F	TW15P HW35L	FTGA03512	SV32S
3232-P16	32	32	170	32	32	55		SHXN0509F	TW15P HW35L	FTGA03512	SV32S	

SVJCR/L

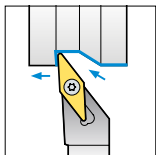

93°

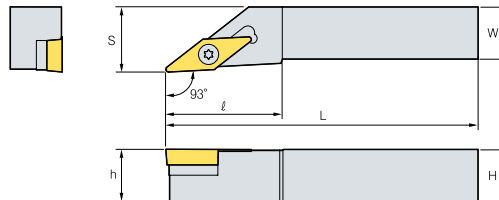

WSP



VC_

Bezeichnung		H	W	L	S	h	ℓ	WSP	Lagenschraube	Schlüssel	Schraube	Zwischenlage
SVJCR/L	1212-F11	12	12	80	16	12	25	VC_1103_	-	TW07P	FTKA02565	-
	1212-F13	12	12	80	16	12	32	VC_1303_	-	TW09P	FTKA0307	-
	1616-H11	16	16	100	20	16	25	VC_1103_	-	TW07P	FTKA02565	-
	1616-H13	16	16	100	20	16	32	VC_1303_	-	TW09P	FTKA0307	-
	1616-H16	16	16	100	20	16	40	VC_1604_	SHXN0509F	TW15P HW35L	FTGA03512	SV32S
	2020-K11	20	20	125	25	20	25	VC_1103_	-	TW07P	FTKA02565	-
	2020-K13	20	20	125	25	20	32	VC_1303_	-	TW09P	FTKA0307	-
	2020-K16	20	20	125	25	20	40	VC_1604_	SHXN0509F	TW15P HW35L	FTGA03512	SV32S
	2525-M11	25	25	150	32	25	42	VC_1103_	-	TW07P	FTKA02565	-
	2525-M13	25	25	150	32	25	43	VC_1303_	-	TW09P	FTKA0307	-
	2525-M16	25	25	150	32	25	40	VC_1604_	SHXN0509F	TW15P HW35L	FTGA03512	SV32S



SVVBN

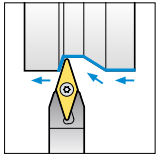

72,5°

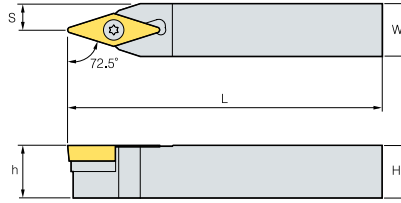

WSP



VB_

(mm)

Bezeichnung		H	W	L	S	h	WSP	Lagenschraube	Schlüssel	Schraube	Zwischenlage
SVVBN	1212-F11	12	12	80	6	12	VB_1102_	-	TW07P	FTKA02565	-
	1616-H11	16	16	100	8	16		-	TW07P	FTKA02565	-
	1616-H16	16	16	100	8	16	VB_1604_	SHXN0509F	TW15P HW35L	FTGA03512	SV32S
	2020-K11	20	20	125	10	20	VB_1102_	-	TW07P	FTKA02565	-
	2020-K16	20	20	125	10	20	VB_1604_	SHXN0509F	TW15P HW35L	FTGA03512	SV32S
	2525-M16	25	25	150	12,5	25		SHXN0509F	TW15P HW35L	FTGA03512	SV32S
	3225-P16	32	25	170	12,5	32		SHXN0509F	TW15P HW35L	FTGA03512	SV32S
	3232-P16	32	32	170	12,5	32		SHXN0509F	TW15P HW35L	FTGA03512	SV32S

SVVCN

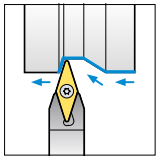

72,5°

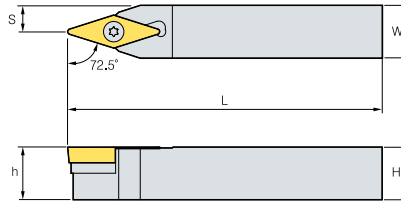

WSP



VC_

(mm)

Bezeichnung		H	W	L	S	h	WSP	Lagenschraube	Schlüssel	Schraube	Zwischenlage
SVVCN	1212-F11	12	12	80	6	12	VC_1103_	-	TW07P	FTKA02565	-
	1212-F13	12	12	80	6	12	VC_1303_	-	TW09P	FTNA0307	-
	1616-H11	16	16	100	8	16	VC_1103_	-	TW07P	FTKA02565	-
	1616-H13	16	16	100	8	16	VC_1303_	-	TW09P	FTNA0307	-
	1616-H16	16	16	100	8	16	VC_1604_	SHXN0509F	TW15P HW35L	FTGA03512	SV32S
	2020-K11	20	20	125	10	20	VC_1103_	-	TW07P	FTKA02565	-
	2020-K13	20	20	125	10	20	VC_1303_	-	TW09P	FTNA0307	-
	2020-K16	20	20	125	10	20	VC_1604_	SHXN0509F	TW15P HW35L	FTGA03512	SV32S
	2525-M16	25	25	150	12,5	25		SHXN0509F	TW15P HW35L	FTGA03512	SV32S



SWACR/L

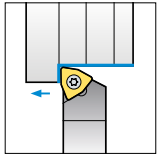

90°

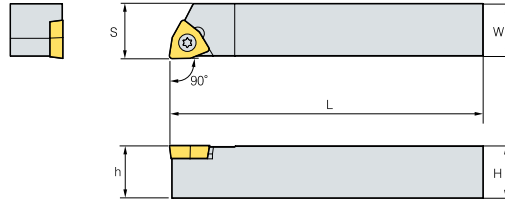

WSP



WC_

Bezeichnung		H	W	L	S	h	WSP	Schlüssel	Schraube
SWACR/L	1010-E04	10	10	70	10,1	10	WC__0402__	TW07P	FTKA02565
	1212-F04	12	12	80	12,1	12		TW07P	FTKA02565
	1616-H06	16	16	100	16,1	16	WC__06T3__	TW15P	FTGA03508
	2020-K08	20	20	125	20,1	20	WC__0804__	TW15P	FTGA0411F

(mm)



CCLNR/L

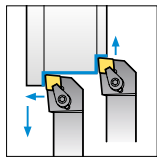

95°

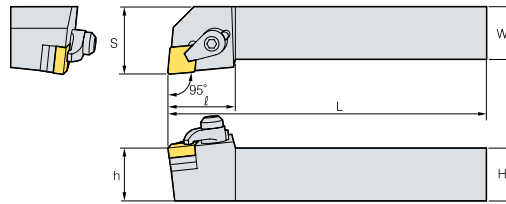

WSP

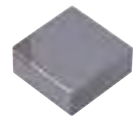

CN_

(mm)

Bezeichnung	H	W	L	S	h	ℓ	WSP	Feder	Klemme	Schlüssel	Schraube	Zwischenlage
CCLNR/L 2525-M12C	25	25	150	32	25	32	CN_N1204_ CN_N1207_	SR3	CH6R3	HW20L HW40L	SHX0310 MHX0630	SC42CC

CRDNN

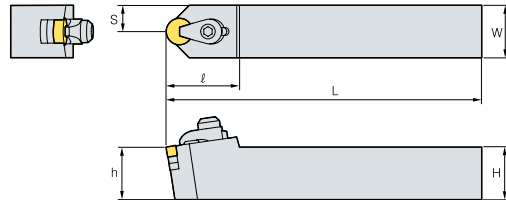
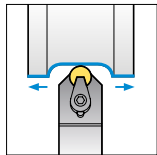

WSP



RN_

(mm)

Bezeichnung	H	W	L	S	h	ℓ	WSP	Feder	Klemme	Schlüssel	Schraube	Zwischenlage
CRDNN 2525-M12C	25	25	150	12,5	25	35	RN_N1204_ RN_N1207_	SR3	CH6R3	HW20L HW40L	SHX0310 MHX0630	SR42CC
3225-P12C	32	25	170	16	32	35		SR3	CH6R3	HW20L HW40L	SHX0310 MHX0630	SR42CC

CRGNR/L

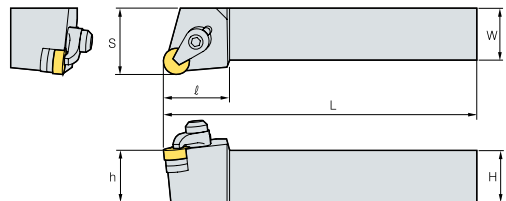
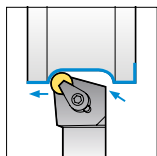

WSP



RN_

(mm)

Bezeichnung	H	W	L	S	h	ℓ	WSP	Feder	Klemme	Schlüssel	Schraube	Zwischenlage
CRGNR/L 2525-M12C	25	25	150	32	25	32	RN_N1204_ RN_N1207_	SR3	CH6R3	HW20L HW40L	SHX0310 MHX0630	SR42CC
3225-P12C	32	25	170	32	32	35		SR3	CH6R3	HW20L HW40L	SHX0310 MHX0630	SR42CC



CSDNN

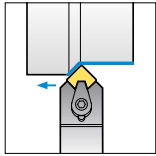

45°

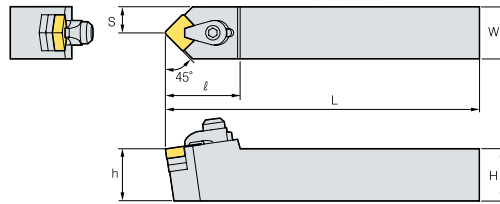

WSP



SN_

Bezeichnung		H	W	L	S	h	ℓ	WSP	Feder	Klemme	Schlüssel	Schraube	Zwischenlage
CSDNN	2525-M12C	25	25	125	12,5	25	35	SN_N1204_ SN_N1207_	SR3	CH6R3	HW20L HW40L	SHX0310 MHX0630	SS42CC
	3225-P12C	32	25	170	16	32	35		SR3	CH6R3	HW20L HW40L	SHX0310 MHX0630	SS42CC

(mm)

CSKNR/L

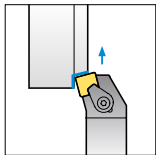

75°

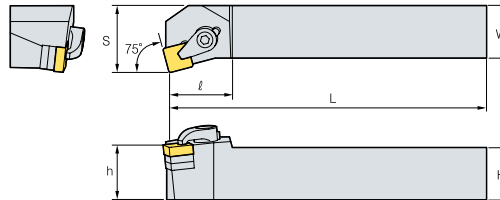

WSP



SN_

Bezeichnung		H	W	L	S	h	ℓ	WSP	Feder	Klemme	Schlüssel	Schraube	Zwischenlage
CSKNR/L	2020-K12C	20	20	125	27	20	28	SN_N1204_ SN_N1207_	SR3	CH6R3	HW20L HW40L	SHX0310 MHX0630	SS42CC
	2525-M12C	25	25	150	32	25	28		SR3	CH6R3	HW20L HW40L	SHX0310 MHX0630	SS42CC
	3225-P12C	32	25	170	32	32	34		SR3	CH6R3	HW20L HW40L	SHX0310 MHX0630	SS42CC

(mm)

KORLOY

CTFNR/L

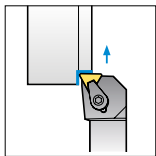

90°

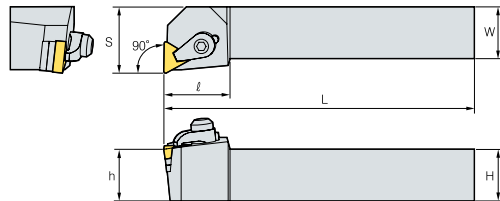

WSP



TP_, TN_

Bezeichnung		H	W	L	S	h	ℓ	WSP	Feder	Klemme	Schlüssel	Schraube	Zwischenlage	
CTFNR/L	2020-K16C	20	20	125	27	20	29	TP_R1603_	SR3	CH6R3	HW20L HW40L	SHX0310 MHX0630	ST32CC	
	2525-M16C	25	25	150	32	25	32		TN_N1604_ TN_N1607_	SR3	CH6R3	HW20L HW40L	SHX0310 MHX0630	ST32CC
	3225-P16C	32	25	170	32	32	29		TP_R1603_	SR3	CH6R3	HW20L HW40L	SHX0310 MHX0630	ST32CC

(mm)



CTGNR/L

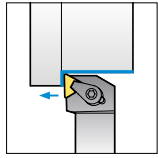

90°

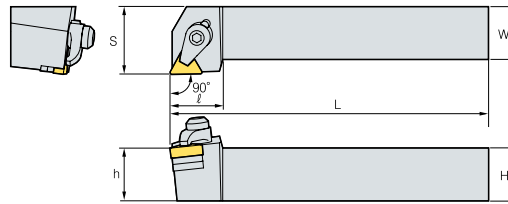

WSP



TN_

(mm)

Bezeichnung		H	W	L	S	h	ℓ	WSP	Feder	Klemme	Schlüssel	Schraube	Zwischenlage
CTGNR/L	2020-K16C	20	20	125	25	20	26	TN_N1604_ TN_N1607_	SR3	CH6R3	HW20L HW40L	SHX0310 MHX0630	ST32CC
	2525-M16C	25	25	150	32	25	26		SR3	CH6R3	HW20L HW40L	SHX0310 MHX0630	ST32CC
	3225-P16C	32	25	170	32	32	26		SR3	CH6R3	HW20L HW40L	SHX0310 MHX0630	ST32CC





KHP Hochdruckhalter

- Verbesserte Standzeiten durch direkte Kühlmittelzufuhr an die Schneidkante
- Verbesserter Widerstand gegen Ausbrüche und geringerer Kerbverschleiß
- Höhere Vorschübe durch direkte Kühlmittelzufuhr an den Eckenradius
- Besserer Spanbruch durch die Verwendung von hohem Kühlmitteldruck

Kühlmitteldüse

- Optimale Positionierung der Kühlmitteldüse
- Maximaler Kühlmitteldruck durch optimierten Kühlkanal
- Einfacher Plattenwechsel durch seitlich verschiebbare Kühlmitteldüse

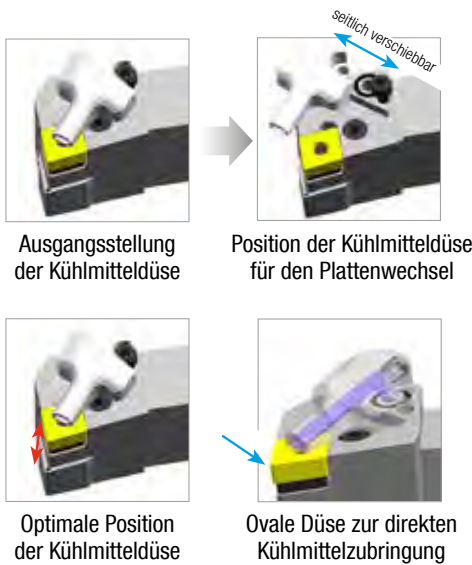

Richtung der Kühlmittelzufuhr



MAX 300 bar

Werkstück		Mindestdruck (bar)	Maximaldruck (bar)
P	Stahl	50	300
M	Rostfreier Stahl	70	
K	Gusseisen	60	
N	NE-Metalle	50	
S	HRSA	70	

Verbesserte Spankontrolle

- **Werkstück** HRSA (Inconel718, HRC42)
- **Schnittbedingungen** $vc = 50$ m/min, $fn = 0,25$ mm/U, $ap = 2$ mm, nass (70 bar)
- **Werkzeug**
WSP CNMG120408-VP4
Halter PCLNR2525-M12-KHP

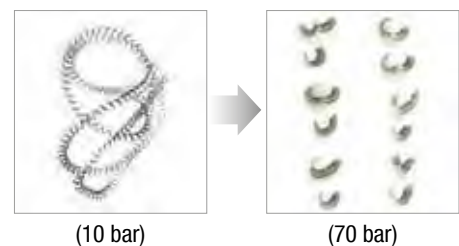



P	S	K	N	R	25	25	-	M	12	KHP
1	2	3	4	5	6	7		8	9	10
Spann- system	Wende- schneid- plattenform	Einstell- winkel	Freiwinkel	Werkzeug- richtung	Schafthöhe	Schafthöhe		Werkzeug- länge	Schneidkanten- länge	KORLOY Hochdruck- kühlung

KHP Halteraufbau

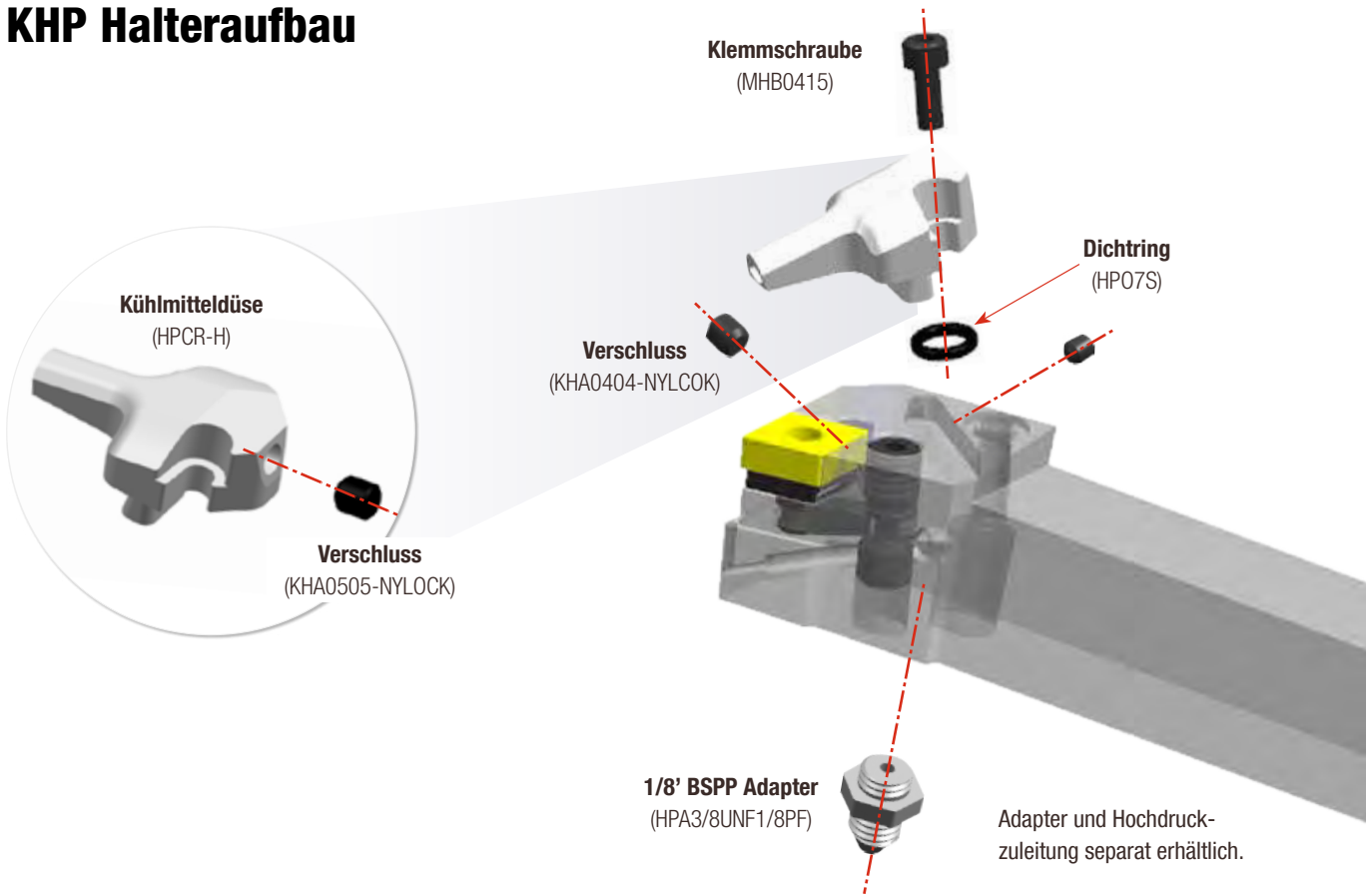

Hinweis zum einfachen Plattenwechsel





PCLNR/L

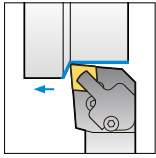

95°
Rechts-Ausführung

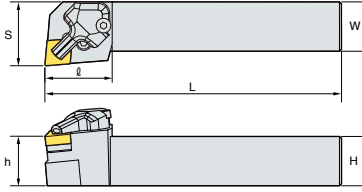

Bezeichnung	H	W	L	S	h	ℓ	WSP	Kniehebel	Schraube	Unterlegscheibe	Hülse	Schlüssel	Stift Unterlegscheibe	Pratze	Klemmschraube	Dichtung	Verschluss	(mm)	
PCLNR 2525-M12-KHP	25	25	150	32	25	34	CN_1204_	LV4N	VHX0820N	SC42N	SP4N	HW20L HW30L	LSPS4	HPCR-H	MHB0415	HPO7S	KHA0404-NYLOCK		
3232-P12-KHP	32	32	170	40	32	34													

PDJNR/L

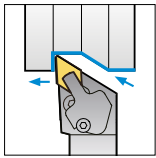

93°
Rechts-Ausführung

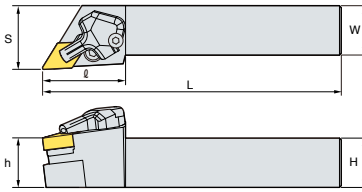

Bezeichnung	H	W	L	S	h	ℓ	WSP	Kniehebel	Schraube	Unterlegscheibe	Hülse	Schlüssel	Stift Unterlegscheibe	Pratze	Klemmschraube	Dichtung	Verschluss	(mm)			
PDJNR 2525-M11-KHP	25	25	150	32,25	25	42	DN_1104_	LV3AN	VHX0617N	SD32N	SP3	HW20L HW25L HW30L	LSPS3	HPCR-H	MHB0415	HPO7S	KHA0404-NYLOCK				
2525-M1504-KHP	25	25	150	32,25	25	42	DN_1504_	LV4BN	VHX0821N	SD42N	SP4N	HW20L HW30L	LSPS4								
2525-M1506-KHP	25	25	150	32,25	25	42	DN_1506_			SD43N											

PWLNR/L

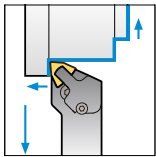

95°
Rechts-Ausführung

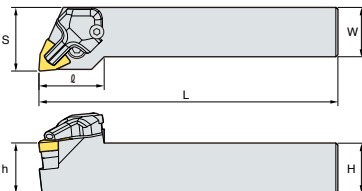

Bezeichnung	H	W	L	S	h	ℓ	WSP	Kniehebel	Schraube	Unterlegscheibe	Hülse	Schlüssel	Stift Unterlegscheibe	Pratze	Klemmschraube	Dichtung	Verschluss	(mm)	
PDJNR 2525-M11-KHP	25	25	150	32,25	25	33	WN_0803_	LV4N	VHX0820N	SW42N	SP4N	HW20L HW30L	LSPS4	HPCR-H	MHB0415	HPO7S	KHA0404-NYLOCK		
2525-M1504-KHP	32	32	170	39,25	32	33													



SVJBR/L

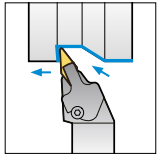

93°
Rechts-Ausführung

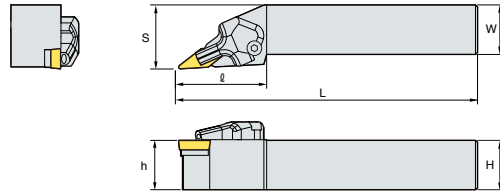

(mm)

Bezeichnung	H	W	L	S	h	l	WSP	Schraube	Schraube Unterlegscheibe	Unterlegscheibe	Schlüssel	Pratze	Klemmschraube	Dichtung
SVJBR 2525-M16-KHP	25	25	150	32.5	25	46.5	VB_1604_	FTGA03512	SHXN0509F	SV32S	TW15P HW30L HW35L	HPCR-H	MHB0415	HP07S

Zubehör

Zubehör	Bezeichnung	Abbildung
Adapter	HPA3/8UNF1/8PF	
Kupplung	HPB1/8PF	
Banjo Schraube	HPZ1/8PF	
Unterlegscheibe	HPW1/8PF	

Schläuche

Typ	Abbildung	Länge	Gewindegröße S	Gewindegröße B
Gerade/Gerade (S-S) (HPH3/8UNF)		200 mm	3/8 UNF	-
		250 mm		
Gerade/Banjo (S-B) (HPH3/8UNF1/8PF)		200 mm	3/8 UNF	1/8 PF
		250 mm		
Banjo/Banjo (B-B) (HPH1/8PF)		200 mm	-	1/8 PF
		250 mm		

! Hinweis

- Nutzen Sie Standardschlüssel zur Befestigung.
- Vermeiden Sie Kontakt mit austretendem Kühlmittel durch verbliebenen Druck im Schlauch.
- Befestigen Sie die Teile sicher.
- Reinigen Sie die Maschine vor der Benutzung.
- Der O-Ring wird mitgeliefert und muss nicht separat bestellt werden.



S 12 M - S T F P R - 11

- ①
Schaftausführung
- ②
Schaftdurchmesser
- ③
Werkzeuglänge
- ④
Spannsystem
- ⑤
Wendeschneidplattenform
- ⑥
Einstellwinkel
- ⑦
Freiwinkel
- ⑧
Werkzeugrichtung
- ⑨
Schneidkantenlänge

1 Schaftausführung
S 12 M - S T F P R - 11

- S Stahlschaft
- A Stahl mit Kühlmittelbohrung
- C Hartmetallschaft
- E Hartmetallstange mit festem Stahlkopf und Kühlmittelbohrung
- X Spezialausführung

2 Schaftdurchmesser
S 12 M - S T F P R - 11

3 Werkzeuglänge
S 12 M - S T F P R - 11

Länge (L)	(mm)
H	100
J	110
K	125
M	150
N	160
Q	180
R	200
S	250
T	300
U	350
V	400
W	450
Y	500

4 Spannsystem
S 12 M - S T F P R - 11

5 Wendeschneidplattenform
S 12 M - S T F P R - 11

6 Einstellwinkel
S 12 M - S T F P R - 11

7 Freiwinkel
S 12 M - S T F P R - 11

8 Werkzeugrichtung
S 12 M - S T F P R - 11

9 Schneidkantenlänge
S 12 M - S T F P R - 11



Anweisungen zur Montage von Bohrstangen

Doppelklemmsystem (D)

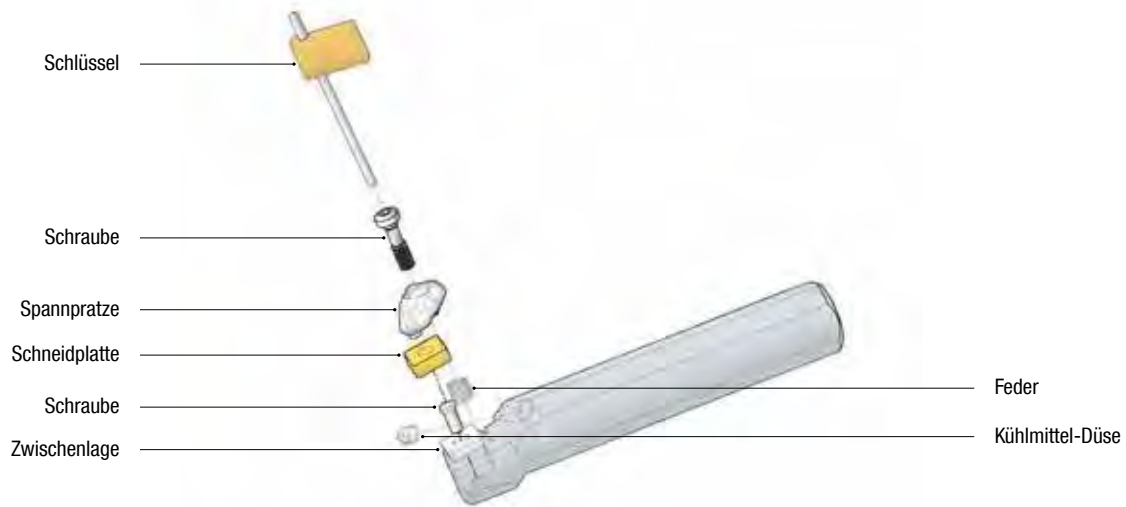

Mit mit Stift und Spannpratzen

Kniehebelsystem (P)

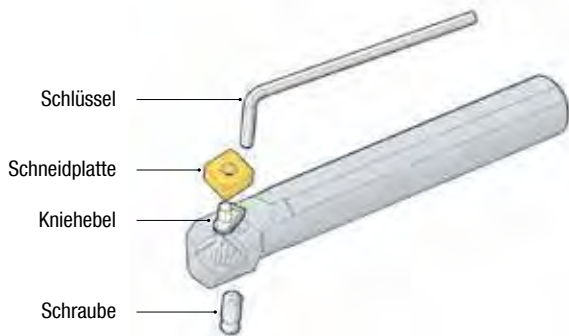

Mit Kniehebel

Klemmsystem (C)

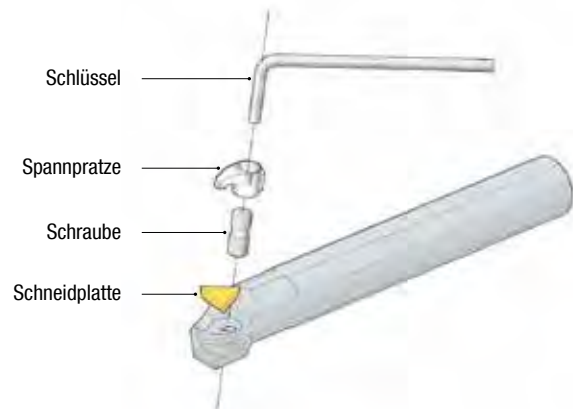

Mit Spannpratzen

Mehrfachklemmsystem (M)

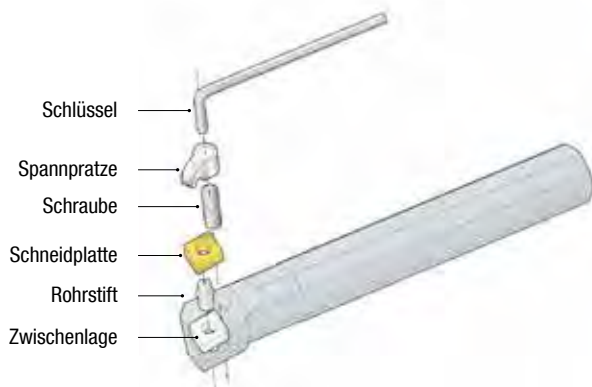

Mit Stift und Spannpratzen

Schraubsystem (S)

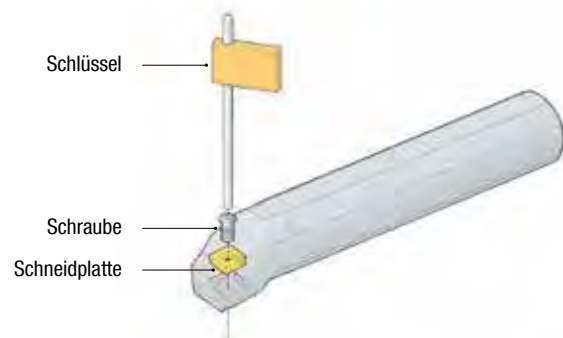

Schraubenspannung



Doppelklemmsystem

Schnittform								
Bezeichnung	DCLNR/L	DDSNR/L	DDUNR/L	DSKNR/L	DTFNR/L	DWLNR/L		
Anstellwinkel	95°	95°	93°	75°	90°	95°		
Seite	59	59	59	60	60	61		
Kopieren			•					
Plandrehen	•	•				•		
Rückwärtsdrehen			•					
Drehen	•	•	•	•	•	•		

Kniehebelsystem

Schnittform								
Bezeichnung	PCLNR/L	PDQNR/L	PDSNR/L	PDUNR/L	PSKNR/L	PTFNR/L	PWLNR/L	
Anstellwinkel	95°	62,5°	62,5°	93°	75°	90°	95°	
Seite	62	63	63	64	65	65	66	
Kopieren		•	•	•				
Plandrehen	•						•	
Rückwärtsdrehen		•	•	•		•	•	
Drehen	•	•	•	•	•	•	•	



Klemmsystem

Schnittform								
Bezeichnung	CKUNR/L	CSKPR/L	CTFPR/L					
Anstellwinkel	93°	75°	90°					
Seite	67	68	68					
Kopieren								
Plandrehen								
Rückwärtsdrehen	•							
Drehen	•	•	•					

Mehrfachklemmsystem

Schnittform								
Bezeichnung	MCLNR/L	MDUNR/L	MSKNR/L	MTFNR/L	MTUNR/L	MVUNR/L	MWLNR/L	
Anstellwinkel	95°	93°	75°	90°	90°	93°	95°	
Seite	69	69	70	70	70	71	71	
Kopieren		•				•		
Plandrehen	•						•	
Rückwärtsdrehen		•				•	•	
Drehen	•	•	•	•	•	•	•	



Schraubsystem

Schnittform										
Bezeichnung	SCKCR/L	SCLCR/L	SCLPR/L	SDQCR/L	SDUCR/L	SDZCR/L	SSKCR/L	SSSCR/L	SSKPR/L	STFCR/L
Anstellwinkel	95°	95°	95°	107.5°	93°	3°	75°	75°	75°	90°
Seite	72	72	73	73	74	75	75	76	76	77
Kopieren				•	•					
Plandrehen	•	•	•							
Rückwärtsdrehen				•	•	•				
Drehen	•	•	•	•	•	•	•	•	•	•

Schnittform										
Bezeichnung	STFPR/L	STUBR/L	STUPR/L	STWPR/L	SVJCR/L	SVQBR/L	SVQCR/L	SVUBR/L	SVUCR/L	SWLCR/L
Anstellwinkel	90°	90°	90°	60°	142°	108°	108°	93°	93°	95°
Seite	77	78	78	79	79	80	80	81	81	82
Kopieren					•	•	•	•	•	•
Plandrehen										
Rückwärtsdrehen	•	•	•			•	•	•	•	•
Drehen	•	•	•	•	•	•	•	•	•	•

Compact Mini

Schnittform								
Bezeichnung	SCLCR/L	STUBR/L	STUPR/L	SWUBR/L				
Anstellwinkel	95°	93°	93°	93°				
Seite	83	83	84	85				
Kopieren								
Plandrehen	•	•						
Rückwärtsdrehen			•					
Drehen	•	•	•	•				

Bohrstange mit Hartmetallschaft

Bezeichnung	SCLCR/L	SCLPR/L	SDQCR/L	SDUCR/L	STFCR/L
Anstellwinkel	95°	95°	107,5°	93°	91°
Seite	85	86	86	87	88

Bezeichnung	STFPR/L	STUBR/L	STUPR/L	SWUBR/L	
Anstellwinkel	91°	93°	93°	93°	
Seite	89	89	90	90	



DCLNR/L

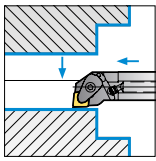

95°

Min. Bearbeitungsdurchm.

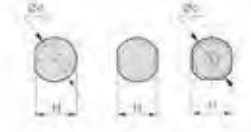
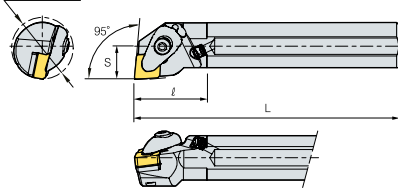

WSP



CN_

(mm)

Bezeichnung	ØD	Ød	H	L	S	ℓ	Spannflächen	WSP	Düse	Feder	Klemme	Klemmschraube	Lagenschraube	Schlüssel	Zwischenlage
A25R-DCLNR/L-09	32	25	23	200	17	27	3	CN_0903_	CN0605	SPR0510	CVH3	CHX0415	FTKA0307	HW25P	SC32V
A25R-DCLNR/L-12	32	25	23	200	17	28	3	CN_1204_	CN0605	SPR0714	CVH4	CHX0518	FTKA0410	HW30P	SC42V
A32S-DCLNR/L-12	40	32	30	250	22	27	3		CN0605	SPR0714	CVH4	CHX0518	FTKA0410	HW30P	SC42V
A32U-DCLNR/L-12	40	32	30	350	22	27	3		CN0605	SPR0714	CVH4	CHX0518	FTKA0410	HW30P	SC42V
A40T-DCLNR/L-12	50	40	37	300	27	30	3		CN0605	SPR0714	CVH4	CHX0518	FTKA0410	HW30P	SC42V
A40V-DCLNR/L-12	50	40	37	400	27	60	3		CN0605	SPR0714	CVH4	CHX0518	FTKA0410	HW30P	SC42V
A50U-DCLNR/L-16	63	50	47	350	35	40	3	CN_1606_	CN0605	SPR0811	CVH5	CHX0622	FTNA0511	HW40L	SC54V

DDSNR/L

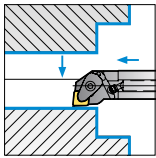

95°

Min. Bearbeitungsdurchm.

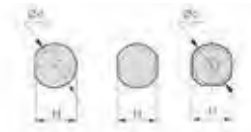
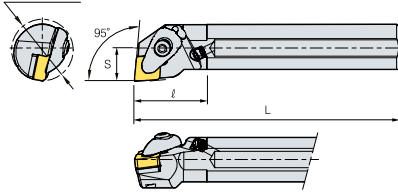

WSP



CN_

(mm)

Bezeichnung	ØD	Ød	H	L	S	ℓ	Spannflächen	WSP	Düse	Feder	Klemme	Klemmschraube	Lagenschraube	Schlüssel	Zwischenlage
S32S-DDSNR/L-11	40	32	30	250	22	25	3	DN_1104_	CN0605	SPR0510	CVH3	CHX0415	FTKA0307	HW25P	SD32V

DDUNR/L

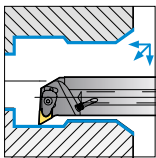

93°

Min. Bearbeitungsdurchm.

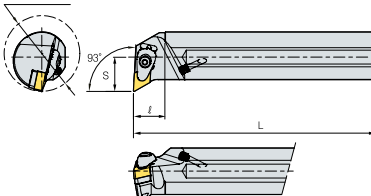

WSP



DN_

(mm)

Bezeichnung	ØD	Ød	H	L	S	ℓ	Spannflächen	WSP	Düse	Feder	Klemme	Klemmschraube	Lagenschraube	Schlüssel	Zwischenlage
A32S-DDUNR/L-11	40	32	30	250	22	25	3	DN_1104_	CN0605	SPR0510	CVH3	CHX0415	FTKA0307	HW25P	SD32V
A40V-DDUNR/L-15	50	40	37	400	27	60	3	DN_1506_	CN0605	SPR0714	CVH4	CHX0518	FTKA0410	HW30P	SD44V
A40T-DDUNR/L-15	50	40	37	300	27	25	3		CN0605	SPR0714	CVH4	CHX0518	FTKA0410	HW30P	SD44V
A40T-DDUNR/L-15-3	50	40	37	300	27	25	3	DN_1504_	CN0605	SPR0714	CVH4	CHX0518	FTKA0410	HW30P	SD43V
A50U-DDUNR/L-15	63	50	47	350	35	30	3	DN_1506_	CN0605	SPR0714	CVH4	CHX0518	FTKA0410	HW30P	SD44V
A50U-DDUNR/L-15-3	63	50	47	350	35	30	3	DN_1504_	CN0605	SPR0714	CVH4	CHX0518	FTKA0410	HW30P	SD43V



DSKNR/L

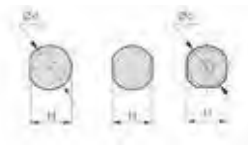
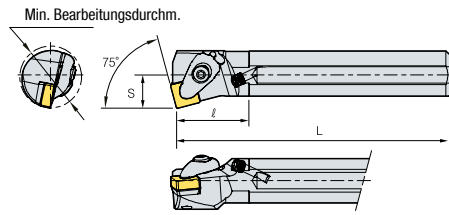
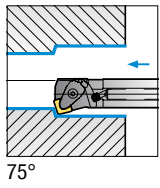

WSP



SN_

Bezeichnung	ØD	Ød	H	L	S	ℓ	Spannflächen	WSP	Düse	Feder	Klemme	Klemmschraube	Lagenschraube	Schlüssel	Zwischenlage
A25R-DSKNR/L-09	32	25	23	200	17	27	3	SN_0903_	CN0605	SPR0510	CVH3	CHX0415	FTKA0307	HW25P	SS32V
A25R-DSKNR/L-12	32	25	23	200	17	28	3	SN_1204_	CN0605	SPR0714	CVH4	CHX0518	FTKA0410	HW30P	SS42V
A32S-DSKNR/L-12	40	32	30	250	22	28	3		CN0605	SPR0714	CVH4	CHX0518	FTKA0410	HW30P	SS42V
A40T-DSKNR/L-12	50	40	37	300	27	28	3		CN0605	SPR0714	CVH4	CHX0518	FTKA0410	HW30P	SS42V

(mm)

DTFNR/L

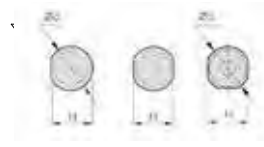
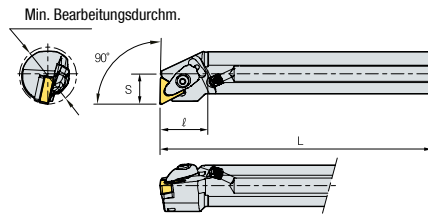
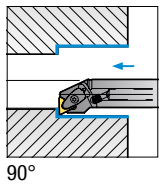

WSP



TN_

Bezeichnung	ØD	Ød	H	L	S	ℓ	Spannflächen	WSP	Düse	Feder	Klemme	Klemmschraube	Lagenschraube	Schlüssel	Zwischenlage
A25R-DTFNR/L-16	32	25	23	200	17	27	3	TN_1604_	CN0605	SPR0510	CVH3	CHX0415	FTKA0307	HW25P	ST32V
A32S-DTFNR/L-16	40	32	30	250	22	27	3		CN0605	SPR0510	CVH3	CHX0415	FTKA0307	HW25P	ST32V
A40T-DTFNR/L-22	50	40	37	300	27	33	3	TN_2204_	CN0605	SPR0714	CVH4	CHX0518	FTKA0410	HW30P	ST44V
A50U-DTFNR/L-22	63	50	47	350	35	33	3		CN0605	SPR0714	CVH4	CHX0518	FTKA0410	HW30P	ST44V
S32S-DTFNR/L-16	40	32	30	250	22	27	3	TN_1604_	CN0605	SPR0510	CVH3	CHX0415	FTKA0307	HW25P	ST32V
S32U-DTFNR/L-16	40	32	30	350	22	33	3		CN0605	SPR0510	CVH3	CHX0415	FTKA0307	HW25P	ST32V

(mm)



DWLNR/L

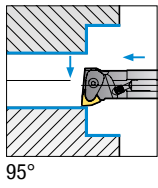

Min. Bearbeitungsdurchm.

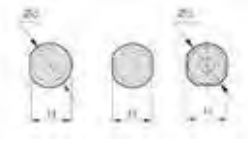
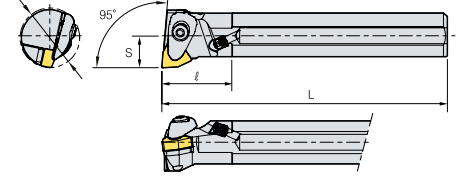

WSP



WN_

(mm)

Bezeichnung	ØD	Ød	H	L	S	ℓ	Spannflächen	WSP	Düse	Feder	Klemme	Klemmschraube	Lagenschraube	Schlüssel	Zwischenlage
A25R-DWLNR/L-06	32	25	23	200	17	19	3	WN_0604_	CN0605	SPR0510	CVH3	CHX0415	FTKA0307	HW25P	SW32V
A25R-DWLNR/L-08	33	25	23	200	17	20	3	WN_0804_	CN0605	SPR0714	CVH4	CHX0518	FTKA0410	HW30P	SW42V
A32S-DWLNR/L-06	40	32	30	250	22	20	3	WN_0604_	CN0605	SPR0510	CVH3	CHX0415	FTKA0307	HW25P	SW32V
A32S-DWLNR/L-08	40	32	30	250	22	24	3	WN_0804_	CN0605	SPR0714	CVH4	CHX0518	FTKA0410	HW30P	SW42V
A40T-DWLNR/L-06	50	40	37	300	27	25	3	WN_0604_	CN0605	SPR0510	CVH3	CHX0415	FTKA0307	HW25P	SW32V
A40T-DWLNR/L-08	50	40	37	300	27	25	3	WN_0804_	CN0605	SPR0714	CVH4	CHX0518	FTKA0410	HW30P	SW42V
A50U-DWLNR/L-08	63	50	47	350	35	32	3		CN0605	SPR0714	CVH4	CHX0518	FTKA0410	HW30P	SW42V
S40V-DWLNR/L-08	50	40	37	400	27	35	3		CN0605	SPR0714	CVH4	CHX0518	FTKA0410	HW30P	SW42V

Doppelklemmsystem

- Verbesserte Standzeiten durch das leistungsstarke Klemmsystem und die optimierte Konstruktion
- Justierbare Kühlmitteldüse* zur optimalen Ausrichtung auf die Schneidkante

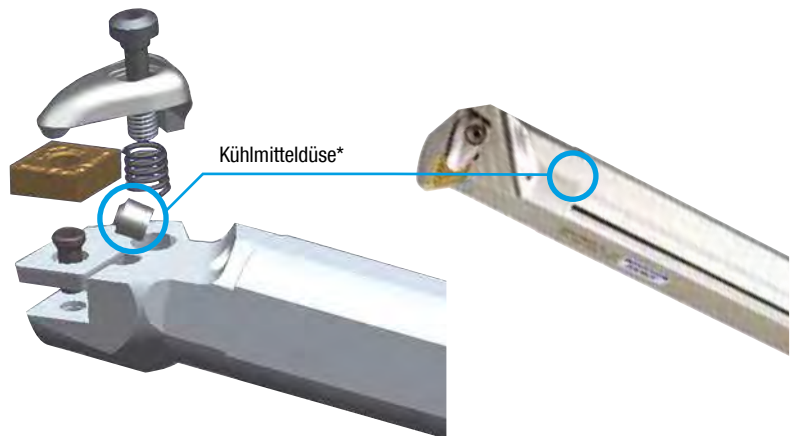



PCLNR/L

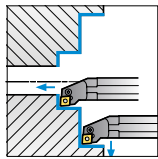

95°

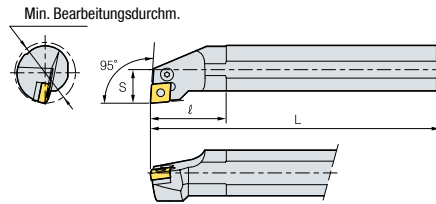

WSP



CN_

(mm)

Bezeichnung	ØD	Ød	H	L	S	ℓ	Spannflächen	WSP	Kniehebel	Rohrstift	Rohrstift-Dorn	Schlüssel	Schraube	Zwischenlage
A16R-PCLNR/L-09	20	16	15	200	11	38	1	CN_0903_	LV3C	-	-	HW20L	VHX0509B	-
A16R-PCLNR/L-09N	20	16	15	200	11	28	1		LV3CN	-	-	HW20L	VHX0509BN	-
A20Q-PCLNR/L-09	25	20	18	180	13	25	3		LV3C	-	-	HW20L	VHX0509B	-
A20Q-PCLNR-09N	25	20	18	180	13	25	3		LV3CN	-	-	HW20L	VHX0509BN	-
A20S-PCLNR/L-09N	25	20	18	250	13	25	3		LV3CN	-	-	HW20L	VHX0509BN	-
A25R-PCLNR/L-09N	32	25	23	200	17	25	3		LV3CN	-	-	HW20L	VHX0509BN	-
A25R-PCLNR/L-12	32	25	24	200	17	40	1	CN_1204_	LV4A	-	-	HW25L	VHX0613A	-
A25R-PCLNR/L-12N	32	25	23	200	17	25	3		LV4AN	-	-	HW25L	VHX0613N	-
A25T-PCLNR/L-12	32	25	23	300	17	25	1		LV4A	-	-	HW25L	VHX0613A	-
A32R-PCLNR/L-12N	40	32	30	250	22	30	3		LV4N	SP4N	LSPS4	HW30L	VHX0817N	SC42N
A32S-PCLNR/L-12	44	32	31	250	22	50	1		LV4	SP4	LSPS4	HW30L	VHX0821	SC42B
A40T-PCLNR/L-12	50	40	47	300	27	60	1		LV4	SP4	LSPS4	HW30L	VHX0821	SC42B
A40T-PCLNR/L-12N	50	40	37	300	27	30	3		LV4N	SP4N	LSPS4	HW30L	VHX0820N	SC42N
A50U-PCLNR/L-12	63	50	47	350	35	30	1		LV4	SP4	LSPS4	HW30L	VHX0821	SC42B
A50U-PCLNR/L-12N	63	50	47	350	35	30	3		LV4N	SP4N	LSPS4	HW30L	VHX0820N	SC42N
A50U-PCLNR/L-19N	63	50	47	350	35	30	3	CN_1906_	LV6N	SP6N	LSPS6	HW40L	VHX1027N	SC63N
S16R-PCLNR/L-09	20	16	15	200	11	28	3	CN_0903_	LV3C	-	-	HW20L	VHX0509B	-
S16R-PCLNR/L-09N	20	16	15	200	11	25	3		LV3CN	-	-	HW20L	VHX0509BN	-
S20Q-PCLNR/L-09-4N	25	20	18	250	13	32	3	CN_0904_	LV3CN	-	-	HW20L	VHX0509BN	-
S20S-PCLNR/L-09	25	20	18	250	13	32	3	CN_0903_	LV3C	-	-	HW20L	VHX0509B	-
S20S-PCLNR/L-09N	25	20	18	250	13	25	3		LV3CN	-	-	HW20L	VHX0509BN	-
S25R-PCLNR/L-09	32	25	23	200	17	36	3	CN_0904_	LV3C	-	-	HW20L	VHX0509B	-
S25R-PCLNR/L-09-4N	32	25	23	200	17	36	3	CN_0903_	LV3CN	-	-	HW20L	VHX0509BN	-
S25R-PCLNR/L-09N	32	25	23	200	17	25	3	CN_0904_	LV3CN	-	-	HW20L	VHX0509BN	-
S25R-PCLNR/L-12	32	25	23	200	17	40	3	CN_1204_	LV4A	-	-	HW25L	VHX0613A	-
S25R-PCLNR/L-12N	32	25	23	200	17	25	3		LV4AN	-	-	HW25L	VHX0613N	-
S25T-PCLNR/L-09	32	25	23	300	17	30	3	CN_0903_	LV3C	-	-	HW20L	VHX0509B	-
S25T-PCLNR/L-12	32	25	23	300	17	25	3	CN_1204_	LV4A	-	-	HW25L	VHX0613A	-
S25T-PCLNR/L-12N	32	25	23	300	17	25	3		LV4AN	-	-	HW25L	VHX0613N	-
S32S-PCLNR/L-09-4N	40	32	30	250	22	50	3	CN_0904_	LV3CN	-	-	HW20L	VHX0509BN	-
S32S-PCLNR/L-12	40	32	30	250	22	50	3	CN_1204_	LV4	SP4	LSPS4	HW30L	VHX0821	SC42B
S32S-PCLNR/L-12N	40	32	30	250	22	30	3		LV4N	SP4N	LSPS4	HW30L	VHX0817N	SC42N
S32U-PCLNR/L-12	40	32	30	350	22	50	3		LV4	SP4	LSPS4	HW30L	VHX0821	SC42B
S32U-PCLNR/L-12N	40	32	30	350	22	30	3		LV4AN	SP4N	LSPS4	HW30L	VHX0820N	SC42N
S32U-PCLNR/L-16	40	32	30	350	22	50	3	CN_1604_	LV5	SP5	LSPS5	HW30L	VHX0825	SC53
S40T-PCLNR/L-12	50	40	37	300	27	55	1	CN_1204_	LV4	SP4	LSPS4	HW30L	VHX0821	SC42B
S40T-PCLNR/L-12N	50	40	37	300	27	30	3		LV4N	SP4N	LSPS4	HW30L	VHX0820N	SC42N
S40V-PCLNR/L-12	50	40	37	400	27	55	3		LV4	SP4	LSPS4	HW30L	VHX0821	SC42B
S50U-PCLNR/L-12	63	50	47	350	35	55	3		LV4	SP4	LSPS4	HW30L	VHX0821	SC42B
S50U-PCLNR/L-12N	63	50	47	350	35	30	3		LV4N	SP4N	LSPS4	HW30L	VHX0820N	SC42N
S50U-PCLNR/L-19	70	50	47	350	35	63	3	CN_1906_	LV6	SP6	LSPS6	HW40L	VHX1027	SC63
S50U-PCLNR/L-19N	63	50	47	350	35	30	3		LV6N	SP6N	LSPS6	HW40L	VHX1027N	SC63N
S50W-PCLNR/L-12	63	50	47	450	35	56	3	CN_1204_	LV4	SP4	LSPS4	HW30L	VHX0821	SC42B
S50W-PCLNR/L-16	63	50	47	450	35	56	3	CN_1604_	LV5	SP5	LSPS5	HW30L	VHX0825	SC53
S50W-PCLNR/L-19	70	50	47	450	35	63	3	CN_1906_	LV6	SP6	LSPS6	HW40L	VHX1027	SC63



PDQNR/L

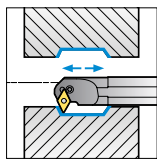

62,5°

Min. Bearbeitungsdurchm.

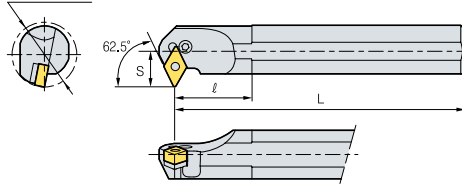

WSP



DN_

(mm)

Bezeichnung	ØD	Ød	H	L	S	ℓ	Spannflächen	WSP	Kniehebel	Rohrstift	Rohrstift-Dorn	Schlüssel	Schraube	Zwischenlage
A32S-PDQNR-11	40	32	31	250	22	45	3	DN_1104_	LV4B	SP4	LSPS4	HW30L	VHX0821	SD42
A32S-PDQNL-15	40	32	31	250	22	45	3	DN_1506_	LV4B	SP4	LSPS4	HW30L	VHX0821	SD42

PDSNR/L

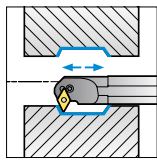

62,5°

Min. Bearbeitungsdurchm.

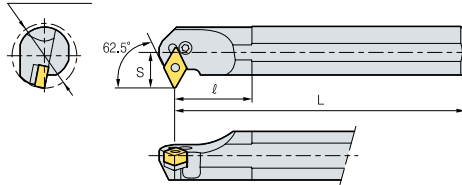

WSP



DN_

(mm)

Bezeichnung	ØD	Ød	H	L	S	ℓ	Spannflächen	WSP	Kniehebel	Rohrstift	Rohrstift-Dorn	Schlüssel	Schraube	Zwischenlage
A32S-PDSNR/L-15	40	32	31	250	22	45	3	DN_1506_	LV4B	SP4	LSPS4	HW30L	VHX0821	SD42
A32S-PDSNR/L-15N	40	32	30	250	22	15	3		LV4BN	SP4N	LSPS4	HW30L	VHX0821	SD42N
A32S-PDSNR/L-15-3	40	32	31	250	22	45	3	DN_1504_	LV4	SP4	LSPS4	HW30L	VHX0821	SD42
A32S-PDSNR/L-15-3N	40	32	30	450	22	15	3		LV4BN	SP4N	LSPS4	HW30L	VHX0821	SD43N
A40T-PDSNR/L-15N	50	40	37	300	27	15	3	DN_1506_	LV4BN	SP4N	LSPS4	HW30L	VHX0821	SD42N
A40T-PDSNR/L-15-3N	50	40	37	300	27	15	3	DN_1504_	LV4BN	SP4N	LSPS4	HW30L	VHX0821	SD43N
S32S-PDSNR/L-15	40	32	30	250	22	45	3	DN_1506_	LV4B	SP4	LSPS4	HW30L	VHX0821	SD42
S32S-PDSNR/L-15N	40	32	30	250	22	15	3		LV4BN	SP4N	LSPS4	HW30L	VHX0821	SD42N
S32S-PDSNR/L-15-3	40	32	30	450	22	45	3	DN_1504_	LV4	SP4	LSPS4	HW30L	VHX0821	SD42
S32S-PDSNR/L-15-3N	40	32	30	250	22	15	3		LV4BN	SP4N	LSPS4	HW30L	VHX0821	SD43N
S32U-PDSNR/L-15	40	32	30	350	22	45	3	DN_1506_	LV4B	SP4	LSPS4	HW30L	VHX0821	SD42
S32U-PDSNR/L-15-3	40	32	30	350	27	45	3	DN_1504_	LV4	SP4	LSPS4	HW30L	VHX0821	SD42
S40T-PDSNR/L-15	50	40	37	300	27	43	3	DN_1506_	LV4B	SP4	LSPS4	HW30L	VHX0821	SD42
S40T-PDSNR/L-15N	50	40	37	300	27	15	3		LV4BN	SP4N	LSPS4	HW30L	VHX0821	SD42N
S40T-PDSNR/L-15-3	50	40	37	300	27	43	3	DN_1504_	LV4	SP4	LSPS4	HW30L	VHX0821	SD42
S40T-PDSNR/L-15-3N	50	40	37	300	27	15	3		LV4BN	SP4N	LSPS4	HW30L	VHX0821	SD43N
S40V-PDSNR/L-15	50	40	37	400	27	45	3	DN_1506_	LV4B	SP4	LSPS4	HW30L	VHX0821	SD42
S40V-PDSNR/L-15-3	50	40	37	400	27	45	3	DN_1504_	LV4	SP4	LSPS4	HW30L	VHX0821	SD42



PDUNR/L

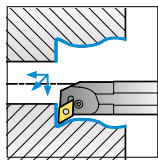

93°

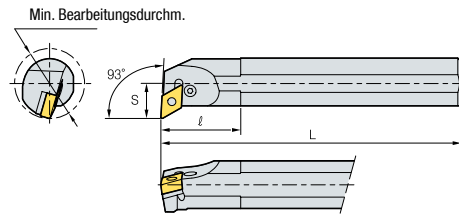

WSP



DN_

(mm)

Bezeichnung	ØD	Ød	H	L	S	ℓ	Spannflächen	WSP	Kniehebel	Rohrstift	Rohrstift-Dorn	Schlüssel	Schraube	Zwischenlage
A20S-PDUNR/L-11N	25	20	18	250	13	25	3	DN__1104__	LV3DN	-	-	HW20L	VHX0512BN	-
A25R-PDUNR/L-11N	32	25	23	200	17	35	2		LV3DN	-	-	HW20L	VHX0512BN	-
A32S-PDUNR/L-11N	40	32	30	250	22	40	3		LV3AN	SP3N-1	LSPS3	HW30L	VHX0617N	SD317N
A32S-PDUNR/L-15	40	32	31	250	22	50	3	DN__1506__	LV4B	SP4	LSPS4	HW30L	VHX0821	SD42
A32S-PDUNR/L-15-3	40	32	31	250	22	50	3	DN__1504__	LV4	SP4	LSPS4	HW30L	VHX0821	SD42
A32S-PDUNR/L-15-3N	40	32	30	250	22	50	3		LV4BN	SP4N	LSPS4	HW30L	VHX0821N	SD43N
A32S-PDUNR/L-15N	40	32	30	250	22	50	3	DN__1506__	LV4BN	SP4N	LSPS4	HW30L	VHX0821N	SD42N
A40T-PDUNR/L-15	50	40	37	300	27	60	3		LV4B	SP4	LSPS4	HW30L	VHX0821	SD42
A40T-PDUNR/L-15-3N	50	40	37	300	27	50	3	DN__1504__	LV4BN	SP4N	LSPS4	HW30L	VHX0821N	SD43N
A40T-PDUNR/L-15N	50	40	37	300	27	50	3	DN__1506__	LV4BN	SP4N	LSPS4	HW30L	VHX0821N	SD42N
A50U-PDUNR/L-15N	63	50	47	350	35	50	3		LV4BN	SP4N	LSPS4	HW30L	VHX0821N	SD42N
S20S-PDUNR/L-11	25	20	18	250	13	30	3	DN__1104__	LV3D	-	-	HW20L	VHX0512B	-
S20S-PDUNR/L-11N	25	20	18	250	13	25	3		LV3DN	-	-	HW20L	VHX0512BN	-
S25R-PDUNR/L-11	32	25	23	200	17	35	3		LV3D	-	-	HW20L	VHX0512B	-
S25R-PDUNR/L-11N	32	25	23	200	17	35	3		LV3DN	-	-	HW20L	VHX0512BN	-
S25T-PDUNR/L-11	32	25	23	300	17	35	3		LV3D	-	-	HW20L	VHX0512B	-
S32S-PDUNR/L-11	40	32	30	250	22	40	3		LV3	SP3	LSPS3	HW25L	VHX0617	SD317
S32S-PDUNL-11-5N	40	32	30	250	22	40	3	DN__1105__	LV3AN	SP3N-0	LSPS2	HW30L	VHX0617N	SD317N
S32S-PDUNR/L-11N	40	32	30	250	22	40	3	DN__1104__	LV3AN	SP3N-1	LSPS3	HW30L	VHX0617N	SD317N
S32S-PDUNR/L-15	40	32	30	250	22	50	3	DN__1506__	LV4B	SP4	LSPS4	HW30L	VHX0821	SD42
S32S-PDUNR/L-15-3	40	32	30	250	22	50	3	DN__1504__	LV4	SP4	LSPS4	HW30L	VHX0821	SD42
S32S-PDUNR/L-15-3N	40	32	30	250	22	50	3		LV4BN	SP4N	LSPS4	HW30L	VHX0821N	SD43N
S32S-PDUNR/L-15N	40	32	30	250	22	50	3	DN__1506__	LV4BN	SP4N	LSPS4	HW30L	VHX0821N	SD42N
S32U-PDUNR/L-11	40	32	30	350	22	40	3	DN__1104__	LV4B	SP4	LSPS4	HW30L	VHX0821	SD42
S32U-PDUNR/L-15	40	32	30	350	22	50	3	DN__1506__	LV4B	SP4	LSPS4	HW30L	VHX0821	SD42
S32U-PDUNR/L-15-3	40	32	30	350	22	50	3	DN__1504__	LV4	SP4	LSPS4	HW30L	VHX0821	SD42
S32U-PDUNR/L-15N	40	32	30	350	22	50	3	DN__1506__	LV4BN	SP4	LSPS4	HW30L	VHX0821N	SD42N
S40T-PDUNR/L-11-5N	50	40	37	300	27	50	3	DN__1105__	LV3AN	SP3N-0	LSPS2	HW30L	VHX0617N	SD317N
S40T-PDUNR/L-15	50	40	37	300	27	50	3	DN__1506__	LV4B	SP4	LSPS4	HW30L	VHX0821	SD42
S40T-PDUNR/L-15-3	50	40	37	300	27	50	3	DN__1504__	LV4	SP4	LSPS4	HW30L	VHX0821	SD42
S40T-PDUNR/L-15-3N	50	40	37	300	27	50	3		LV4BN	SP4N	LSPS4	HW30L	VHX0821N	SD43N
S40T-PDUNR/L-15N	50	40	37	300	27	50	3	DN__1506__	LV4BN	SP4N	LSPS4	HW30L	VHX0821N	SD42N
S40V-PDUNR/L-15	50	40	37	400	27	50	3		LV4B	SP4	LSPS4	HW30L	VHX0821	SD42
S40V-PDUNR/L-15-3	50	40	37	400	27	50	3	DN__1504__	LV4	SP4	LSPS4	HW30L	VHX0821	SD42
S50U-PDUNR/L-15	63	50	47	350	35	63	3	DN__1506__	LV4B	SP4	LSPS4	HW30L	VHX0821	SD42
S50U-PDUNR/L-15N	63	50	47	350	35	50	3		LV4BN	SP4N	LSPS4	HW30L	VHX0821N	SD42N
S50W-PDUNR/L-15	63	50	47	450	35	55	3		LV4B	SP4	LSPS4	HW30L	VHX0821	SD42



PSKNR/L

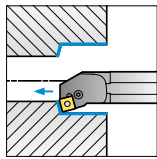

75°

Min. Bearbeitungsdurchm.

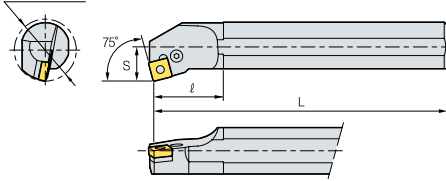

WSP



SN_

(mm)

Bezeichnung	ØD	Ød	H	L	S	ℓ	Spannflächen	WSP	Kniehebel	Rohrstift	Rohrstift-Dorn	Schlüssel	Schraube	Zwischenlage
A25R-PSKNR/L-12	32	25	23	200	17	42	1	SN_1204_	LV4A	SP4	-	HW25L	VHX0613A	-
A25R-PSKNR/L-12N	32	25	23	200	17	25	3		LV4AN	-	-	HW25L	VHX0613N	-
A32S-PSKNR/L-12	40	32	30	250	22	50	1		LV4	SP4	LSPS4	HW30L	VHX0821	SS42B
A32S-PSKNR/L-12N	40	32	30	250	22	30	3		LV4N	SP4N	LSPS4	HW30L	VHX0821N	SS42N
A40T-PSKNR/L-12N	50	40	37	300	27	30	3		LV4N	SP4N	LSPS4	HW30L	VHX0821N	SS42N
S25R-PSKNR/L-09-4N	32	25	23	200	17	25	3	SN_0903_	LV4AN	-	-	HW25L	VHX0613N	-
S25R-PSKNR/L-12	32	25	23	200	17	42	3	SN_1204_	LV4A	-	-	HW25L	VHX0613A	-
S25R-PSKNR/L-12N	32	25	23	200	17	25	3		LV4AN	-	-	HW25L	VHX0613N	-
S25T-PSKNR/L-12	32	25	23	300	17	42	3		LV4A	-	-	HW25L	VHX0613A	-
S32S-PSKNR/L-09-4N	40	32	30	250	22	30	3	SN_0903_	LV4N	SP4N	LSPS4	HW30L	VHX0821N	SS42N
S32S-PSKNR/L-12	40	32	30	250	22	45	3	SN_1204_	LV4	SP4	LSPS4	HW30L	VHX0821	SS42B
S32S-PSKNR/L-12N	40	32	30	250	22	30	3		LV4N	SP4N	LSPS4	HW30L	VHX0821N	SS42N
S32U-PSKNR/L-12	40	32	30	350	22	45	3		LV4	SP4	LSPS4	HW30L	VHX0821	SS42B
S40T-PSKNR/L-12	50	40	37	300	27	50	3		LV4	SP4	LSPS4	HW30L	VHX0821	SS42B
S40T-PSKNR/L-12N	50	40	37	300	27	30	3		LV4N	SP4N	LSPS4	HW30L	VHX0821N	SS42N
S40V-PSKNR/L-12	50	40	37	400	27	50	3		LV4	SP4	LSPS4	HW30L	VHX0821	SS42B

PTFNR/L

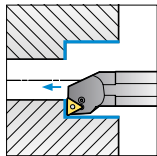

90°

Min. Bearbeitungsdurchm.

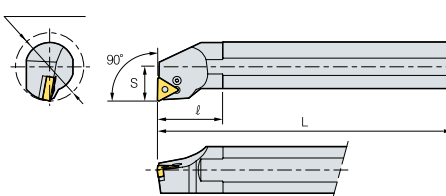

WSP



TN_

(mm)

Bezeichnung	ØD	Ød	H	L	S	ℓ	Spannflächen	WSP	Kniehebel	Rohrstift	Rohrstift-Dorn	Schlüssel	Schraube	Zwischenlage
A25R-PTFNR/L-16	32	25	24	200	17	40	1	TN_1604_	LV3	SP3	LSPS3	HW25L	VHX0617	ST317B
A25R-PTFNR/L-16N	32	25	23	200	17	42	3		LV3BN	-	-	HW20L	VHX0512B	-
A32S-PTFNR/L-16	40	32	31	250	22	50	1		LV3	SP3	LSPS3	HW25L	VHX0617	ST317B
A32S-PTFNR/L-16N	44	32	30	250	22	50	1		LV3N	SP3N	LSPS3	HW25L	VHX0617N	ST317N
A40T-PTFNR/L-16	54	40	37	300	27	55	1		LV4	SP4	LSPS4	HW30L	VHX0821	SS42B
A40T-PTFNR/L-16N	54	40	37	300	27	55	1		LV3N	SP3N	LSPS3	HW25L	VHX0617N	ST317N
S16R-PTFNR/L-11	20	16	15	200	11	28	3	TN_1103_	LV2	-	-	HW25L	VHX0509B	-
S20S-PTFNR/L-11	25	20	18	250	13	3			LV2	-	-	HW25L	VHX0509B	-
S25R-PTFNR/L-11	32	25	23	200	17	36	3		LV2	-	-	HW25L	VHX0509B	-
S25R-PTFNR/L-16	32	25	23	200	17	42	3	TN_1604_	LV3B	-	-	HW20L	VHX0512B	-
S25R-PTFNR/L-16N	32	25	23	200	17	42	3		LV3BN	-	-	HW20L	VHX0512B	-
S25T-PTFNR/L-11	32	25	23	300	17	36	3	TN_1103_	LV3B	-	-	HW20L	VHX0512B	-
S25T-PTFNR/L-16	32	25	23	300	17	40	3	TN_1604_	LV3B	-	-	HW20L	VHX0512B	-
S25T-PTFNR/L-16N	32	25	23	300	17	40	3		LV3B	-	-	HW20L	VHX0512B	-
S32S-PTFNR/L-16	44	32	30	250	22	50	3		LV3	SP3	LSPS3	HW25L	VHX0617	ST317B
S32S-PTFNR/L-16N	44	32	30	250	22	50	3		LV3N	SP3N	LSPS3	HW25L	VHX0617N	ST317N
S32U-PTFNR/L-16	40	32	30	350	22	42	3		LV3	SP3	LSPS3	HW25L	VHX0617	ST317B
S40T-PTFNR/L-16	54	40	37	300	27	55	3		LV3	SP3	LSPS3	HW25L	VHX0617	ST317B
S40T-PTFNR/L-16N	54	40	37	300	27	55	3		LV3N	SP3N	LSPS3	HW25L	VHX0617N	ST317N
S40V-PTFNR/L-16	40	40	37	400	27	40	3		LV3	SP3	LSPS3	HW25L	VHX0617	ST317B



PWLNR/L

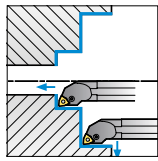

95°

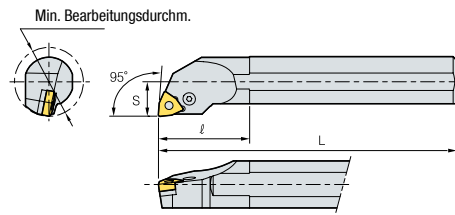

WSP



WN_

(mm)

Bezeichnung	ØD	Ød	H	L	S	ℓ	Spannflächen	WSP	Kniehebel	Rohrstift	Rohrstift-Dorn	Schlüssel	Schraube	Zwischenlage
A25T-PWLNR/L-08	32	25	23	300	17	42	1	WN_0804_	LV4A	-	-	HW25L	VHX0613A	-
S16Q-PWLNR/L-06	20	16	15	180	11	40	3	WN_0604_	LV4A	-	-	HW25L	VHX0613A	-
S16R-PWLNR/L-06	20	16	15	200	11	40	3		LV3B	-	-	HW20L	VHX0512B	-
S20S-PWLNR/L-06	25	20	18	250	13	40	3		LV3B	-	-	HW20L	VHX0512B	-
S20S-PWLNR/L-06N	25	20	18	250	13	40	3		LV3B	-	-	HW20L	VHX0512B	-
S25R-PWLNR/L-06	32	25	23	200	17	40	3		LV3B	SP3	LSPS3	HW25L	VHX0613B	SW317
S25R-PWLNR/L-06N	32	25	23	200	17	40	3		LV4	SP4	LSPS3	HW30L	VHX0821	SW42
S25R-PWLNR/L-08	32	25	23	200	17	45	3		WN_0804_	LV4	SP4	LSPS3	HW30L	VHX0821
S25R-PWLNR/L-08N	32	25	23	200	17	25	3	WN_0804_	LV4	SP4	LSPS3	HW30L	VHX0821	SW42
S25T-PWLNR/L-06	32	25	23	300	17	40	3	WN_0604_	LV3B	-	-	HW20L	VHX0512B	-
S25T-PWLNR/L-08	32	25	23	300	17	42	3	WN_0804_	LV3BN	-	-	HW20L	VHX0512BN	-
S32S-PWLNR/L-06	44	32	30	250	22	45	3	WN_0604_	LV3BN	-	-	HW20L	VHX0512BN	-
S32S-PWLNR/L-06N	44	32	30	250	22	45	3	WN_0804_	LV4A	-	-	HW25L	VHX0613A	-
S32S-PWLNR/L-08	44	32	30	250	22	50	3		LV4AN	-	-	HW25L	VHX0613N	-
S32S-PWLNR/L-08N	44	32	30	250	22	25	3	WN_0604_	LV3B	SP3	LSPS3	HW25L	VHX0613B	SW317
S32U-PWLNR/L-06	40	32	30	350	22	48	3		LV3B	-	-	HW20L	VHX0512B	-
S32U-PWLNR/L-08	44	32	30	350	22	50	3	WN_0804_	LV3N	SP3N	LSPS3	HW25L	VHX0617N	SW317N
S40V-PWLNR/L-08	50	40	37	400	27	58	3	WN_0804_	LV4	SP4	LSPS3	HW30L	VHX0821	SW42
S40T-PWLNR/L-08	54	40	37	300	27	55	3		LV4N	SP4N	LSPS4	HW30L	VHX0820N	SW42N



CKUNR/L

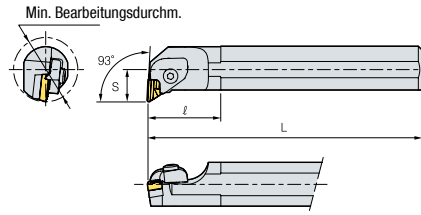
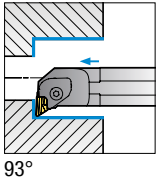

WSP



KN_

(mm)

Bezeichnung	ØD	Ød	H	L	S	ℓ	Spannflächen	WSP	Feder	Klemme	Klemmschraube	Lagenschraube	Schlüssel	Stift	Zwischenlage
S32S-CKUNL-16	40	32	30	250	22	70	3	KN_1604_R	SR3 SR4	CTH6RI	CHX0625	SHX0310	HW20L HW40L	PN0515	SK33C
S32S-CKUNR-16	40	32	30	250	22	70	3	KN_1604_L	SR3 SR4	CTH6LI	CHX0625	SHX0310	HW20L HW40L	PN0515	SK33CL
S32U-CKUNL-16	40	32	30	350	22	55	3	KN_1604_R	SR3 SR4	CTH6RI	CHX0625	SHX0310	HW20L HW40L	PN0515	SK33C
S32U-CKUNR-16	40	32	30	350	22	55	3	KN_1604_L	SR3 SR4	CTH6RI	CHX0625	SHX0310	HW20L HW40L	PN0515	SK33C
S40T-CKUNL-16	50	40	37	300	27	60	3	KN_1604_R	SR3 SR4	CTH6RI	CHX0625	SHX0310	HW20L HW40L	PN0515	SK33C
S40T-CKUNR-16	50	40	37	300	27	60	3	KN_1604_L	SR3 SR4	CTH6LI	CHX0625	SHX0310	HW20L HW40L	PN0515	SK33CL
S40V-CKUNR-16	50	40	37	400	27	60	3		SR3 SR4	CTH6RI	CHX0625	SHX0310	HW20L HW40L	PN0515	SK33C
S50U-CKUNL-16	63	50	43	350	35	55	3	KN_1604_R	SR3 SR4	CTH6RI	CHX0625	SHX0310	HW20L HW40L	PN0515	SK33C
S50U-CKUNR-16	63	50	43	350	35	55	3	KN_1604_L	SR3 SR4	CTH6LI	CHX0625	SHX0310	HW20L HW40L	PN0515	SK33CL
S50W-CKUNR-16	63	50	47	450	35	65	3		SR3 SR4	CTH6RI	CHX0625	SHX0310	HW20L HW40L	PN0515	SK33C



CSKPR/L

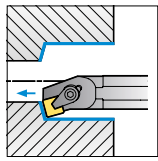

75°

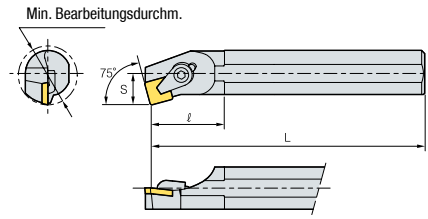

WSP

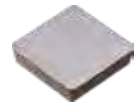

SP_

(mm)

Bezeichnung	ØD	Ød	H	L	S	ℓ	Spannflächen	WSP	C-Ring	Klemme	Klemmschraube	Schlüssel
S16R-CSKPR/L-09	20	16	15	200	11	30	3	SP_0903_	CR02C	CH4R1C	CHX0414	HW25L
S20S-CSKPR/L-09	25	20	18	250	13	36	2	SP_1203_	CR02C	CH4R1C	CHX0414	HW25L
S20S-CSKPR/L-12	25	20	18	250	13	28	3		CR03C	CH5R5C	CHX0519C	HW30L
S25R-CSKPR/L-12	32	25	23	200	17	40	3		CR04C	CH6R5	CH0616	HW30L
S25T-CSKPR/L-12	32	25	23	300	17	42	3		CR04C	CH6R5	CH0616	HW30L

CTFPR/L

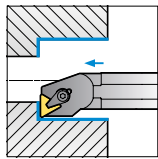

90°

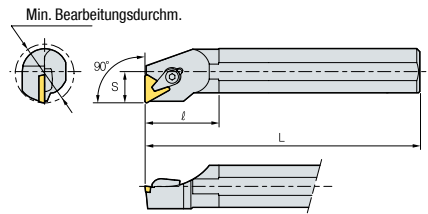

WSP



TP_

(mm)

Bezeichnung	ØD	Ød	H	L	S	ℓ	Spannflächen	WSP	C-Ring	Klemme	Klemmschraube	Rohrstift	Schlüssel	Zwischenlage
S12M-CTFPR/L-11	16	12	11	150	9	26	3	TP_1103_	CR02C	CH4R1C	CHX0414C	-	HW25L	-
S16R-CTFPR/L-11	20	16	15	200	11	40	3		CR02C	CH4R1C	CHX0414C	-	HW25L	-
S16R-CTFPR/L-16	20	16	15	200	11	40	3	TP_1603_	CR03C	CH5R5C	CHX0519C	-	HW30L	-
S20S-CTFPR/L-11	25	20	18	250	13	40	3	TP_1103_	CR02C	CH4R1C	CHX0414C	-	HW25L	-
S20S-CTFPR/L-16	25	20	18	250	13	40	3	TP_1603_	CR03C	CH5R5C	CHX0519C	-	HW30L	-
S25R-CTFPR/L-16	32	25	23	200	17	40	3		CR04C	CH6R5	CHX0622C	-	HW30L	-
S25T-CTFPR/L-16	32	25	23	300	17	40	3	TP_2204_	CR04C	CH6R5	CHX0622C	SP3C	HW30L	ST32C
S32S-CTFPR/L-16	40	32	30	250	22	45	3		CR04C	CH6R5	CHX0622C	SP3C	HW30L	ST32C
S32U-CTFPR/L-16	40	32	30	350	22	50	3		CR04C	CH6R5	CHX0622C	SP3C	HW30L	ST32C
S40T-CTFPR/L-16	50	40	37	300	27	60	3		CR04C	CH6R5	CHX0622C	SP3C	HW30L	ST32C
S40T-CTFPR/L-22	50	40	37	300	27	60	3	TP_2204_	CR05C	CH83R1	CH0823C	SP4C	HW40L	ST43C
S40V-CTFPR/L-16	50	40	37	400	27	60	3	TP_1603_	CR04C	CH6R5	CHX0622C	SP3C	HW30L	ST32C
S40V-CTFPR/L-22	50	40	37	400	27	60	3	TP_2204_	CR05C	CH83R1	CH0823C	SP4C	HW40L	ST43C



MCLNR/L

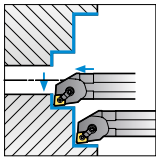

95°

Min. Bearbeitungsdurchm.

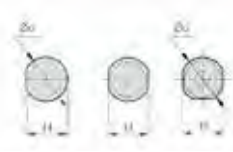
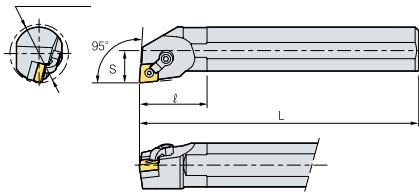

WSP



CN_

(mm)

Bezeichnung	ØD	Ød	H	L	S	ℓ	Spannflächen	WSP	Klemme	Klemmschraube	Rohrstift	Schlüssel	Zwischenlage
A25R-MCLNR/L-12	32	25	23	200	17	45	1	CN_1204_	CDH6N	DHA1/4-21	SP4DS	HW23.8L HW31.8L	-
A32S-MCLNR/L-12	40	32	30	250	22	45	1		CDH6N	DHA1/4-21	SP4D	HW23.8L HW31.8L	SC43D
A40V-MCLNL-19	50	40	37	400	27	50	1	CN_1906_	CDH6N	DHA1/4-21	SP4D	HW23.8L HW31.8L	SC43D
S20S-MCLNR/L-09	25	20	18	250	13	30	3	CN_0903_	CDH7N	DHA10-32-19	SP3D3S	"HW19.8L HW23.8L"	-
S25R-MCLNR/L-09	32	25	23	200	17	36	3	CN_0903_	CDH7N	DHA10-32-19	SP3D3S	"HW19.8L HW23.8L"	-
S25R-MCLNR/L-12	32	25	23	200	17	40	3	CN_1204_	CDH6N	DHA1/4-21	SP4DS	"HW23.8L HW31.8L"	-
S25T-MCLNR/L-12	32	25	23	300	17	35	3		CDH6N	DHA1/4-21	SP4DS	"HW23.8L HW31.8L"	-
S32S-MCLNR/L-12	40	32	30	250	22	45	3		CDH6N	DHA1/4-21	SP4D	"HW23.8L HW31.8L"	SC43D
S32U-MCLNR/L-12	40	32	30	350	22	45	3		CDH6N	DHA1/4-21	SP4D	"HW23.8L HW31.8L"	SC43D
S40T-MCLNR/L-12	50	40	37	300	27	50	3		CDH6N	DHA1/4-21	SP4D	"HW23.8L HW31.8L"	SC43D
S40V-MCLNR/L-12	50	40	37	400	27	50	3		CDH6N	DHA1/4-21	SP4D	"HW23.8L HW31.8L"	SC43D

MDUNR/L

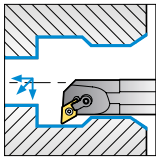

93°

Min. Bearbeitungsdurchm.

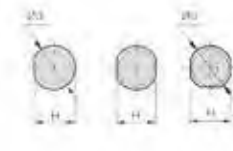
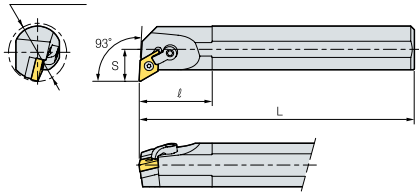

WSP



DN_

(mm)

Bezeichnung	ØD	Ød	H	L	S	ℓ	Spannflächen	WSP	Klemme	Klemmschraube	Rohrstift	Schlüssel	Zwischenlage
A32S-MDUNR/L-15-3	40	32	30	250	22	50	1	DN_1504_	CDH6N	DHA1/4-21	SP4D	HW23.8L HW31.8L	SD43D
S32S-MDUNR/L-15-3	40	32	30	250	22	50	3		CDH6N	DHA1/4-21	SP4D	HW23.8L HW31.8L	SD43D
S32U-MDUNR/L-15	40	32	30	350	22	50	3	DN_1506_	CDH6N	DHA1/4-21	SP4D	HW23.8L HW31.8L	SS43D
S32U-MDUNR/L-15-3	40	32	30	350	22	50	3	DN_1504_	CDH6N	DHA1/4-21	SP4D	HW23.8L HW31.8L	SS43D
S40T-MDUNR/L-15-3	50	40	37	300	27	60	3		CDH6N	DHA1/4-21	SP4D	HW23.8L HW31.8L	SD43D
S40V-MDUNR/L-15	50	40	37	400	27	60	3	DN_1506_	CDH6N	DHA1/4-21	SP4D	HW23.8L HW31.8L	SS43D
S40V-MDUNR/L-15-3	50	40	37	400	27	50	3	DN_1504_	CDH6N	DHA1/4-21	SP4D	HW23.8L HW31.8L	SS43D



MSKNR/L

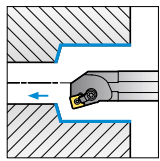

75°

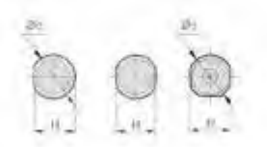
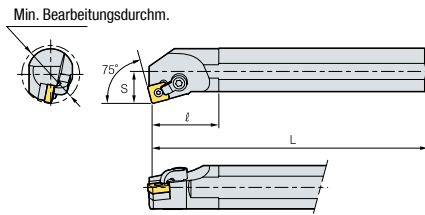

WSP



SN_

(mm)

Bezeichnung	ØD	Ød	H	L	S	ℓ	Spannflächen	WSP	Klemme	Klemmschraube	Rohrstift	Schlüssel	Zwischenlage
A25R-MSKNR/L-12	32	25	23	200	17	40	-	SN_1204_	CDH8N1	DHA5/16-28	SP4DS	HW23.8L HW39.7L	
A32S-MSKNR/L-12	40	32	30	250	22	50	-		CDH8N1	DHA5/16-28	SP4D	HW23.8L HW39.7L	SS43D
A40T-MSKNR/L-12	50	40	37	300	27	60	2		CDH8N1	DHA5/16-28	SP4D	HW23.8L HW39.7L	SS43D
S25R-MSKNR/L-12	32	25	23	200	17	36	-		CDH8N1	DHA5/16-28	SP4DS	HW23.8L HW39.7L	
S32S-MSKNR/L-12	40	32	30	250	22	50	3		CDH8N1	DHA5/16-28	SP4D	HW23.8L HW39.7L	SS43D
S40T-MSKNR/L-12	50	40	37	300	27	60	2		CDH8N1	DHA5/16-28	SP4D	HW23.8L HW39.7L	SS43D

MTFNR/L

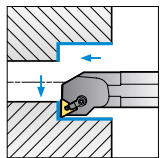

90°

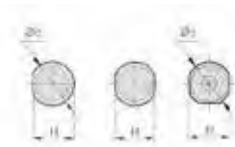
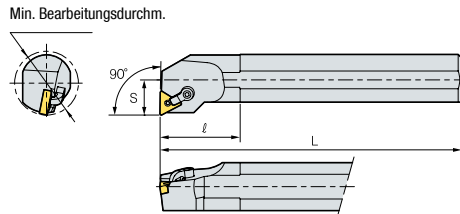

WSP



TN_

(mm)

Bezeichnung	ØD	Ød	H	L	S	ℓ	Spannflächen	WSP	Klemme	Klemmschraube	Rohrstift	Schlüssel	Zwischenlage
A25R-MTFNR/L-16	32	25	23	200	17	40	3	TN_1604_	CDH7N1	DHA10-32-19	SP3D3	HW19.8L HW23.8L	-
A32S-MTFNR/L-16	40	32	30	250	22	45	-		CDH7N1	DHA10-32-19	SP3D	HW19.8L HW23.8L	ST32D
S25R-MTFNR/L-16	32	25	23	200	17	40	3		CDH7N1	DHA10-32-19	SP3D3	HW19.8L HW23.8L	-
S25T-MTFNR/L-16	32	25	23	300	17	40	3		CDH7N1	DHA10-32-19	SP3D3	HW19.8L HW23.8L	-
S32S-MTFNR/L-16	40	32	30	250	22	45	3		CDH7N1	DHA10-32-19	SP3D	HW19.8L HW23.8L	ST32D
S32U-MTFNR/L-16	40	32	30	350	22	50	3		CDH7N1	DHA10-32-19	SP3D	HW19.8L HW23.8L	ST32D
S40T-MTFNR/L-16	50	40	37	300	27	55	3		CDH7N1	DHA10-32-19	SP3D	HW19.8L HW23.8L	ST32D
S40V-MTFNR/L-16	50	40	37	400	27	55	3		CDH7N1	DHA10-32-19	SP3D	HW19.8L HW23.8L	ST32D

MTUNR/L

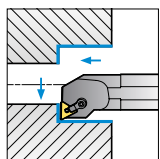

90°

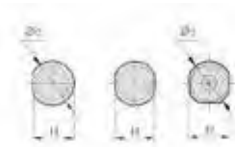
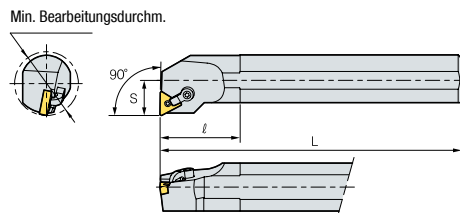

WSP



TN_

(mm)

Bezeichnung	ØD	Ød	H	L	S	ℓ	Spannflächen	WSP	Klemme	Klemmschraube	Rohrstift	Schlüssel	Zwischenlage
S25T-MTUNR-16	32	25	23	300	17	40	-	TN_1604_	CDH7N1	DHA10-32-19	SP3D3	"HW19.8L HW23.8L"	-
S32U-MTUNR-16	40	32	30	350	22	50	-		CDH7N1	DHA10-32-19	SP3D3	"HW19.8L HW23.8L"	-



MVUNR/L

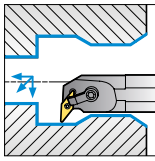

93°

Min. Bearbeitungsdurchm.

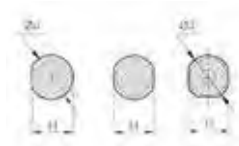
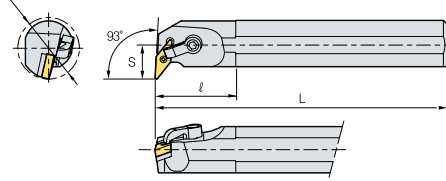

WSP



VN_

(mm)

Bezeichnung	ØD	Ød	H	L	S	ℓ	Spannflächen	WSP	Klemme	Klemmschraube	Rohrstift	Schlüssel	Zwischenlage
A32S-MVUNR/L-16	40	32	30	250	22	50	1	VN_1604_					
A40T-MVUNR/L-16	50	40	37	300	27	55	1		CDH8N2	DHA5/16-28	SP3D	HW19.8L HW39.7L	SV32D
S32S-MVUNR/L-16	40	32	30	250	22	50	3		CDH8N2	DHA5/16-28	SP3D	HW19.8L HW39.7L	SV32D
S32U-MVUNR/L-16	40	32	30	350	22	50	3		CDH8N2	DHA5/16-28	SP3D	HW19.8L HW39.7L	SV32D
S40T-MVUNR/L-16	50	40	37	300	27	55	3		CDH8N2	DHA5/16-28	SP3D	HW19.8L HW39.7L	SV32D
S40V-MVUNR/L-16	50	40	37	400	27	55	3		CDH8N	DHA5/16-28	SP3D2	HW20L HW40L	SV32D2

MWLNR/L

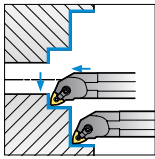

95°

Min. Bearbeitungsdurchm.

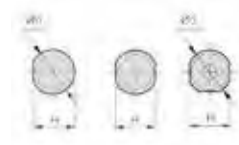
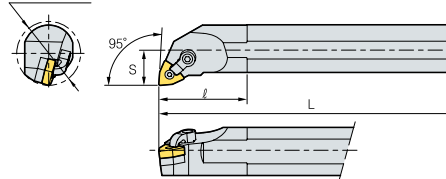

WSP



WN_

(mm)

Bezeichnung	ØD	Ød	H	L	S	ℓ	Spannflächen	WSP	Klemme	Klemmschraube	Rohrstift	Schlüssel	Zwischenlage
A25R-MWLNR/L-06	32	25	23	200	17	35	1	WN_0604_					
A25R-MWLNR/L-08	32	25	23	200	17	40	1	WN_0804_	CDH6N	DHA1/4-21	SP4DS	HW23.8L HW31.8L	-
A32S-MWLNR/L-06	40	32	30	250	22	35	1	WN_0604_	CDH7N	DHA10/32-19	SP3D	HW19.8L HW31.8L	SW32D
A32S-MWLNR/L-08	40	32	30	250	22	45	1	WN_0804_	CDH6N	DHA1/4-21	SP4D	HW23.8L HW31.8L	SW43D
S25R-MWLNR/L-06	32	25	23	200	17	35	3	WN_0604_	CDH7N	DHA10/32-19	SP3D3	HW19.8L HW23.8L	-
S25R-MWLNR/L-08	32	25	23	200	17	40	3	WN_0804_	CDH6N	DHA1/4-21	SP4DS	HW23.8L HW31.8L	-
S25T-MWLNR/L-06	32	25	23	300	17	35	3	WN_0604_	CDH7N	DHA10/32-19	SP3D3	HW19.8L HW23.8L	SW32D
S25T-MWLNR/L-08	32	25	23	300	17	40	3	WN_0804_	CDH6N	DHA1/4-21	SP4DS	HW23.8L HW30L	SW43D
S32U-MWLNR/L-06	40	32	30	350	22	35	3	WN_0604_	CDH7N	DHA10/32-19	SP3D	HW19.8L HW23.8L	SW32D
S32U-MWLNR/L-08	40	32	30	350	22	45	3	WN_0804_	CDH6N	DHA1/4-21	SP4D	HW23.8L HW31.8L	SW43D
S32S-MWLNR/L-06	40	32	30	250	22	35	3	WN_0604_	CDH7N	DHA10/32-19	SP3D	HW19.8L HW23.8L	SW32D
S32S-MWLNR/L-08	40	32	30	250	22	45	3	WN_0804_	CDH6N	DHA1/4-21	SP4D	HW23.8L HW31.8L	SW43D
S40T-MWLNR/L-06	50	40	37	300	27	45	3	WN_0604_	CDH7N	DHA10/32-19	SP3D	HW19.8L HW23.8L	SW43D
S40T-MWLNR/L-08	50	40	37	300	27	52	3	WN_0804_	CDH6N	DHA1/4-21	SP4D	HW23.8L HW31.8L	SW43D
S40V-MWLNR/L-08	50	40	37	400	27	52	3		CDH6N	DHA1/4-21	SP4D	HW23.8L HW31.8L	SW43D



SCKCR/L

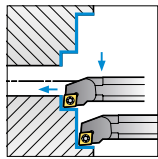

95°

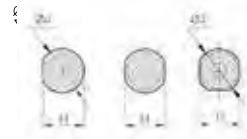
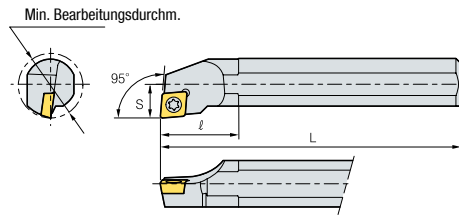

WSP



CC_

(mm)

Bezeichnung	ØD	Ød	H	L	S	ℓ	Spannflächen	WSP	Lagenschraube	Schlüssel	Schraube	Zwischenlage
S10K-SCKCL-06	12	10	9,5	125	6	14	1	CC_0602_	-	TW07P	FTKA02565	-

SCLCR/L

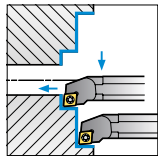

95°

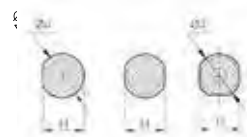
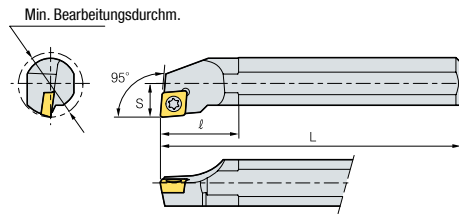

WSP



CC_

(mm)

Bezeichnung	ØD	Ød	H	L	S	ℓ	Spannflächen	WSP	Lagenschraube	Schlüssel	Schraube	Zwischenlage
A08F-SCLCR/L-06	10	8	7,5	80	5	14	1	CC_0602_	-	TW07P	FTKA02555	-
A10H-SCLCR/L-06	12	10	9,5	100	6	14	1	CC_0602_	-	TW07P	FTKA02565	-
A10M-SCLCR/L-06	12	10	9	150	6	18	1		-	TW07P	FTKA02565	-
A12K-SCLCR/L-06	16	12	11	125	9	25	1		-	TW07P	FTKA02565	-
A12K-SCLCR/L-09	16	12	11	125	9	25	1		CC_09T3_	-	TW15P	FTGA03508
A16M-SCLCR/L-09	20	16	15	150	11	32,5	1	CC_09T3_	-	TW15P	FTGA03508	-
A16Q-SCLCR-09	20	16	15	180	11	32,5	1		-	TW15P	FTGA03509	-
A20Q-SCLCR/L-09	25	20	19	180	12		1		-	TW15P	FTGA03508	-
A20Q-SCLCR/L-12	25	20	18	180	13	43	1		CC_1204_	-	TW15P	FTGA0411F
A25R-SCLCR/L-09	32	25	24	200	17	45	1	CC_09T3_	-	TW15P	FTGA03510	-
A25R-SCLCR/L-12	32	25	24	200	17	45	1	CC_1204_	-	TW15P	FTGA0411F	-
A32S-SCLCR/L-12	40	32	31	250	32	50	1	CC_1204_	SHXN0610F	TW15P HW40L	FTGA0411F	SC42S
A40T-SCLCR/L-12	50	40	37	300	27	61	1		SHXN0610F	TW15P HW40L	FTGA0411F	SC42S
S08K-SCLCR/L-06	10	8	7	125	5	14	2	CC_0602_	-	TW07P	FTKA02555	-
S10K-SCLCR/L-06	12	10	9	125	6	14	3	CC_0602_	-	TW07P	FTKA02565	-
S10M-SCLCR/L-06	12	10	9	150	6	14	3		-	TW07P	FTKA02565	-
S12M-SCLCR/L-06	16	12	11	150	9	25	2		-	TW07P	FTKA02565	-
S12M-SCLCR/L-09	16	12	11	150	9	25	2		CC_09T3_	-	TW15P	FTGA03508
S16R-SCLCR/L-06	20	16	15	200	11	32	3	CC_0602_	-	TW07P	FTKA02565	-
S16R-SCLCR/L-09	20	16	15	200	11	32,5	3	CC_09T3_	-	TW15P	FTGA03508	-
S20S-SCLCR/L-09	25	20	18	250	13		2	CC_1204_	-	TW15P	FTGA03508	-
S20S-SCLCR/L-12	25	20	18	250	13	43	3		-	TW15P	FTGA0411F	-
S25R-SCLCR/L-09	32	25	23	200	17	45	3	CC_09T3_	-	TW15P	FTGA03510	-
S25R-SCLCR/L-12	32	25	23	200	17	45	3	CC_1204_	-	TW15P	FTGA0411F	-
S25T-SCLCR/L-09	32	25	23	300	17	45	3	CC_09T3_	-	TW15P	FTGA03510	-
S25T-SCLCR/L-12	32	25	23	300	17	45	3	CC_1204_	-	TW15P	FTGA0411F	-
S32S-SCLCR/L-12	40	32	30	250	22	50	3	CC_1204_	SHXN0610F	TW15P HW40L	FTGA0411F	SC42S
S32U-SCLCR/L-12	40	32	30	350	22	50	3		SHXN0610F	TW15P HW40L	FTGA0411F	SC42S
S40T-SCLCR/L-12	50	40	37	300	27	60	3	CC_1204_	SHXN0610F	TW15P HW40L	FTGA0411F	SC42S
S40V-SCLCR/L-12	50	40	37	400	27	60	3		SHXN0610F	TW15P HW40L	FTGA0411F	SC42S



SCLPR/L

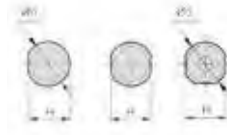
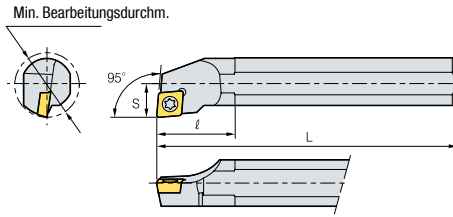
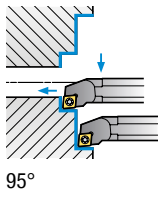

WSP



CP_

Bezeichnung	ØD	Ød	H	L	S	ℓ	Spannflächen	WSP	Schlüssel	Schraube
A10H-SCLPR/L-08	12	10	9,5	100	6	23	1	CP__0802__	TW09P	FTNA0305
A12K-SCLPR/L-08	16	12	11	125	8	20	1		TW09P	FTNA0305
A16M-SCLPR/L-09	20	16	15	150	10	25	1	CP__0903__	TW15P	FTNA0408
A20Q-SCLPR/L-09	25	20	19	180	12,5	28	1		TW15P	FTNA0408
S10M-SCLPR/L-08	12	10	9	150	6	18	3	CP__0802__	TW09P	FTNA0305
S12M-SCLPR/L-08	16	12	11	150	9	20	2		TW09P	FTNA0305
S16N-SCLPR/L-09	20	16	15	160	10	25	3	CP__0903__	TW15P	FTNA0408
S16R-SCLPR/L-09	20	16	15	200	11	35	3		TW15P	FTNA0407
S20N-SCLPR/L-09	25	20	18	160	12,5	25	2		TW15P	FTNA0408
S20S-SCLPR/L-09	25	20	15	250	12,5	28	3		TW15P	FTNA0407

SDQCR/L

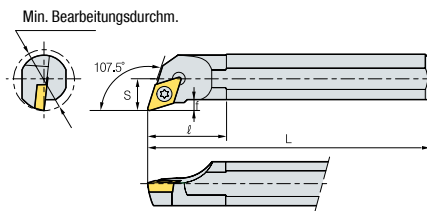
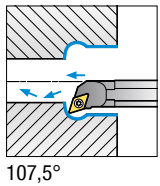

WSP



DC_

Bezeichnung	ØD	Ød	H	L	S	ℓ	f	Spannflächen	WSP	Lagenschraube	Schlüssel	Schraube	Zwischenlage
A10H-SDQCR/L-07	13	10	9,5	100	7	20	2	1	DC__0702__	-	TW07P	FTKA02555	-
A12K-SDQCR/L-07	16	12	11	125	9	22	3	1		-	TW07P	FTKA02565	-
A16M-SDQCR/L-11	20	16	15	150	11	27	3	1	DC__11T3__	-	TW15P	FTGA03508	-
A16M-SDQCR/L-07	20	16	15	150	11	27	3	1	DC__0702__	-	TW07P	FTKA02565	-
A20Q-SDQCR/L-11	25	20	19	180	13	32	3	1	DC__11T3__	-	TW15P	FTGA03508	-
A25R-SDQCR/L-11	32	25	24	200	17	32	4	1		-	TW15P	FTGA03510	-
S10M-SDQCR/L-07	13	10	9	150	7	20	2,5	3	DC__0702__	-	TW07P	FTKA02555	-
S12M-SDQCR/L-07	16	12	11	150	9	22	3,5	3		-	TW07P	FTKA02565	-
S16R-SDQCR/L-07	20	16	15	200	11	27	4	3		-	TW07P	FTKA02565	-
S16R-SDQCR/L-11	20	16	15	200	11	32	4	3	DC__11T3__	-	TW15P	FTGA03508	-
S20S-SDQCR/L-11	25	20	18	250	13	32	4,5	3		-	TW15P	FTGA03508	-
S25R-SDQCR/L-11	32	25	23	200	17	32	7	3		-	TW15P	FTGA03510	-
S25T-SDQCR/L-11	32	25	23	300	17	32	7	3		-	TW15P	FTGA03510	-
S32S-SDQCR/L-11	40	32	30	250	22	40	10	3		-	TW15P	FTGA03510	-
S50W-SDQCR/L-11	63	50	47	450	35	62	12,5	3		SHXN0509F	TW15P HW35L	FTGA03512	SD32S



SDUCR/L

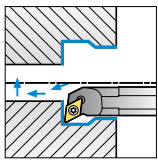

93°

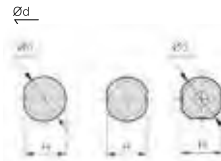
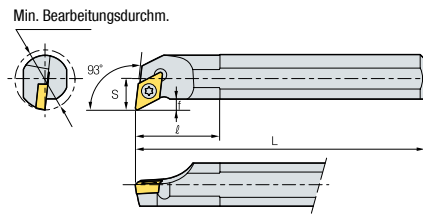

WSP

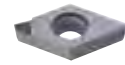

DC_

(mm)

Bezeichnung	ØD	Ød	H	L	S	ℓ	f	Spannflächen	WSP	LAGenschraube	Schlüssel	Schraube	Zwischenlage	
A10H-SDUCR/L-07	13	10	9,5	100	7	20	2	1	DC_0702_	-	TW07P	FTKA02555	-	
A12K-SDUCR/L-07	16	12	11	125	9	22	3	1		-	TW07P	FTKA02565	-	
A16M-SDUCR/L-07	20	16	15	150	11	27	3	1		-	TW07P	FTKA02565	-	
A16R-SDUCR/L-07	20	16	15	200	11	27	3	1		-	TW07P	FTKA02565	-	
A20Q-SDUCR/L-11	25	20	19	180	13	35	3	1	DC_11T3_	-	TW15P	FTGA03508	-	
A25R-SDUCR/L-11	32	25	24	200	17	46	4,5	1		-	TW15P	FTGA03510	-	
A25T-SDUCR/L-11	32	25	23	300	17	46	4,5	1		-	TW15P	FTGA03510	-	
A32U-SDUCR/L-11	40	32	30	350	22	40	10	3		-	TW15P	FTGA03510	-	
A40T-SDUCR/L-11	50	40	37	300	27	50	7	1		SHXN0509F	TW15P HW35L	FTGA03512	SD32S	
A40V-SDUCR-11	50	40	37	400	27	50	9	3		SHXN0509F	TW15P HW35L	FTGA03512	SD32S	
S10M-SDUCR/L-07	13	10	9	150	7	20	2,5	3		DC_0702_	-	TW07P	FTKA02555	-
S12M-SDUCR/L-07	16	12	11	150	9	22	3,5	3			-	TW07P	FTKA02565	-
S16Q-SDUCR/L-11	20	16	15	180	11	27	4	3	DC_11T3_	-	TW15P	FTGA03508	-	
S16R-SDUCR/L-07	20	16	15	200	11	27	4	3	DC_0702_	-	TW07P	FTKA02565	-	
S16R-SDUCR/L-11	20	16	15	200	11	27	4	3	DC_11T3_	-	TW15P	FTGA03508	-	
S20R-SDUCR/L-11	25	20	18	200	13	40	4,5	3	-	TW15P	FTGA03508	-		
S20S-SDUCR/L-07	25	20	18	250	13	29	4,5	3	DC_0702_	-	TW07P	FTKA02565	-	
S20S-SDUCR/L-11	25	20	18	250	13	40	4,3	3	DC_11T3_	-	TW15P	FTGA03508	-	
S25R-SDUCR/L-11	32	25	23	200	17	40	6	3		-	TW15P	FTGA03510	-	
S25T-SDUCR/L-11	32	25	23	300	17	40	6	3		-	TW15P	FTGA03510	-	
S32S-SDUCR/L-11	40	32	30	250	22	40	10	3		-	TW15P	FTGA03510	-	
S32U-SDUCR/L-11	40	32	30	350	22	40	10	3		-	TW15P	FTGA03510	-	
S40T-SDUCR/L-11	50	40	37	300	27	50	9	3		SHXN0509F	TW15P HW35L	FTGA03512	SD32S	
S40V-SDUCR/L-11	50	40	37	400	27	50	9	3		SHXN0509F	TW15P HW35L	FTGA03512	SD32S	
S50W-SDUCR/L-11	63	50	47	450	35	55	12,5	3		-	TW15P	FTGA03510	-	



SDZCR/L

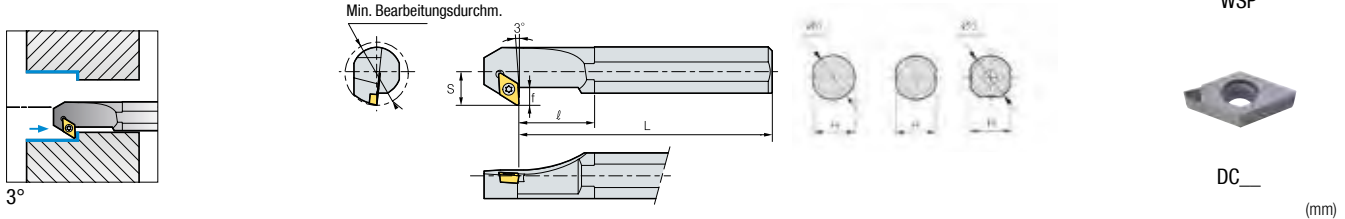

Bezeichnung	ØD	Ød	H	L	S	ℓ	f	Spannflächen	WSP	LAGERSCHRAUBE	SCHLÜSSEL	SCHRAUBE	ZWISCHENLAGE
A25R-SDZCR/L-11	32	25	24	200	17	30	4,5	1	DC_11T3_	-	TW15P	FTGA03510	-
A32S-SDZCR/L-11	40	32	31	250	22	45	11	1		SHXN0509F	TW15P HW35L	FTGA03512	SD32S
S16R-SDZCR/L-07	20	16	15	200	11	20	4	3	DC_0702_	-	TW07P	FTKA02565	-
S20S-SDZCR/L-07	25	20	18	250	13	25	4,5	3		-	TW07P	FTKA02565	-
S25R-SDZCR/L-11	32	25	23	200	17	30	6,9	3	DC_11T3_	-	TW15P	FTGA03510	-
S25T-SDZCR/L-11	32	25	23	300	17	38	9	3		-	TW15P	FTGA03510	-
S32S-SDZCR/L-11	40	32	30	250	22	45	11	3		SHXN0509F	TW15P HW35L	FTGA03512	SD32S
S32U-SDZCR/L-11	40	32	30	350	22	45	11	3		SHXN0509F	TW15P HW35L	FTGA03512	SD32S
S40T-SDZCR/L-11	50	40	37	300	27	55	11	3		SHXN0509F	TW15P HW35L	FTGA03512	SD32S
S40V-SDZCR/L-11	50	40	37	400	27	55	11	3		SHXN0509F	TW15P HW35L	FTGA03512	SD32S

SSKCR/L

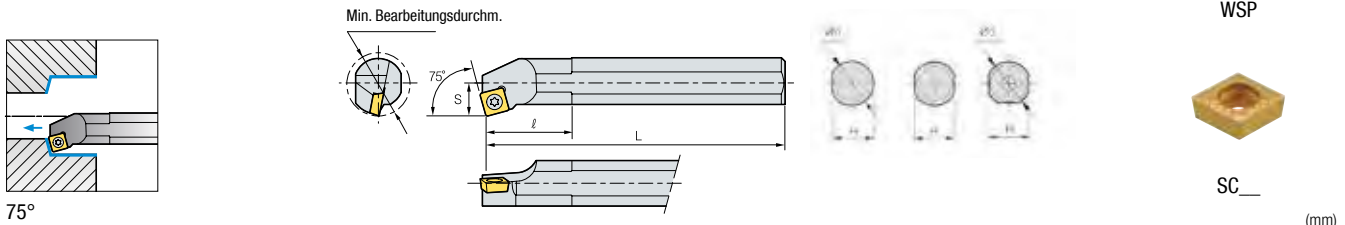

Bezeichnung	ØD	Ød	H	L	S	ℓ	Spannflächen	WSP	LAGERSCHRAUBE	SCHLÜSSEL	SCHRAUBE	ZWISCHENLAGE
A12K-SSKCR/L-09	16	12	11	125	9	25	1	SC_09T3_	-	TW15P	FTGA03507	-
A16M-SSKCR/L-09	20	16	15	150	11	32	1		-	TW15P	FTGA03508	-
A20Q-SSKCR/L-09	25	20	19	180	12	34	1		-	TW15P	FTGA03508	-
A25R-SSKCR/L-12	32	25	24	200	17	41	1	SC_1204_	-	TW15P	FTGA0411F	-
A32S-SSKCR/L-12	40	32	31	250	22	43	1		SHXN0610F	TW15P HW40L	FTGA0411F	SS42S
S12M-SSKCR/L-09	16	12	11	150	9	26	3	SC_09T3_	-	TW15P	FTGA03507	-
S16R-SSKCR/L-09	20	16	15	200	11	32	3		-	TW15P	FTGA03508	-
S20S-SSKCR/L-09	25	20	18	250	13	34	3		-	TW15P	FTGA03508	-
S25R-SSKCR/L-12	32	25	23	200	17	36	3	SC_1204_	-	TW15P	FTGA0411F	-
S25T-SSKCR/L-12	32	25	23	300	17	45	3		-	TW15P	FTGA0411F	-
S32S-SSKCR/L-12	40	32	30	250	22	43	3		SHXN0610F	TW15P HW40L	FTGA0411F	SS42S
S32U-SSKCR/L-12	40	32	30	350	22	43	3		SHXN0610F	TW15P HW40L	FTGA0411F	SS42S



SSSCR/L

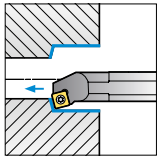

45°

Min. Bearbeitungsdurchm.

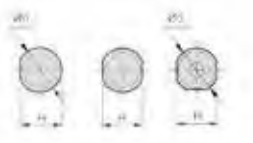
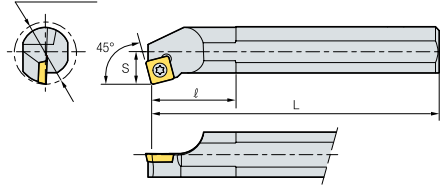

WSP



SC_

(mm)

Bezeichnung	ØD	Ød	H	L	S	ℓ	Spannflächen	WSP	Schlüssel	Schraube	Zwischenlage
A25T-SSSCR-09	32	25	23	300	17	45	-	SC__09T3__	TW15P	FTNA0305	-

SSKPR/L

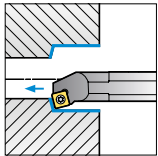

75°

Min. Bearbeitungsdurchm.

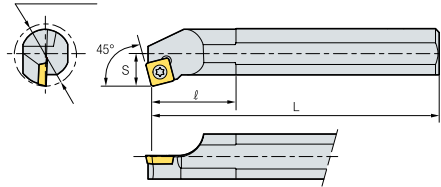

WSP



SP_

(mm)

Bezeichnung	ØD	Ød	H	L	S	ℓ	Spannflächen	WSP	Schlüssel	Schraube
A12K-SSKPR/L-09	16	12	11	125	8	21	1	SP__0903__	TW09P	FTNA0305
A16M-SSKPR/L-09	20	16	15	150	10	30	1		TW09P	FTNA0307
A20Q-SSKPR/L-09	25	20	19	180	12,5	32	1		TW09P	FTNA0307
S12M-SSKPR/L-09	16	12	11	150	8	18	3		TW09P	FTNA0307
S16N-SSKPR/L-09	20	16	15	160	10	30	3		TW09P	FTNA0307
S16R-SSKPR/L-09	20	16	15	200	10	32	3		TW09P	FTNA0307
S20N-SSKPR/L-09	25	20	18	160	12,5	32	3		TW09P	FTNA0307
S20S-SSKPR/L-09	25	20	18	250	12,5	35	3		TW09P	FTNA0307



STFCR/L

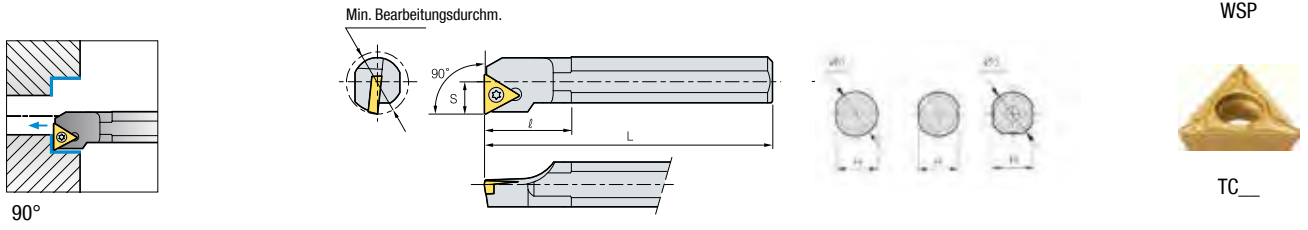

Bezeichnung	ØD	Ød	H	L	S	ℓ	Spannflächen	WSP	Lagenschraube	Schlüssel	Schraube	Zwischenlage
A10H-STFCR/L-09	13	10	9,5	100	7	23	1	TC__0902__	-	TW06P	FTKA02206	-
A12K-STFCR/L-09	16	12	11	125	9	23	1		-	TW06P	FTKA02206	-
A12K-STFCR/L-11	16	12	11	125	9	30	1	TC__1102__	-	TW06P	FTKA02206	-
A16M-STFCR/L-11	20	16	15	150	11	35	1		-	TW07P	FTKA02565	-
A16R-STFCR/L-16	20	16	15	200	11	40	1	TC__16T3__	-	TW07P	FTKA02565	-
A20Q-STFCR/L-11	25	20	19	180	13	36	1	TC__1102__	-	TW07P	FTKA02565	-
A20R-STFCR/L-16	25	20	18	200	13	40	1	TC__16T3__	-	TW07P	FTKA02565	-
A25R-STFCR/L-16	32	25	24	200	17	49	1		-	TW15P	FTKA03510	-
A32S-STFCR/L-16	40	32	31	250	22	50	1		SHXN0509F	TW15P HW35L	FTGA03512	ST32S
A40T-STFCR/L-16	50	40	37	300	27	60	1		SHXN0509F	TW15P HW35L	FTGA03512	ST32S
S10M-STFCR/L-09	13	10	9	150	7	23	3	TC__0902__	-	TW06P	FTKA02206	-
S12M-STFCR/L-09	16	12	11	150	9	28	3		-	TW06P	FTKA02206	-
S12M-STFCR/L-11	16	12	11	150	9	30	3	TC__1102__	-	TW07P	FTKA02565	-
S16R-STFCR/L-11	20	16	15	200	11	35	3		-	TW07P	FTKA02565	-
S20S-STFCR/L-11	25	20	18	250	13	36	3		-	TW07P	FTKA02565	-
S20S-STFCR/L-16	25	20	18	250	13	40	3	TC__16T3__	-	TW15P	FTGA03510	-
S25R-STFCR/L-16	32	25	23	200	17	49	3		-	TW15P	FTGA03510	-
S25T-STFCR/L-16	32	25	23	300	17	40	3		-	TW07P	FTKA02565	-
S32S-STFCR/L-16	40	32	30	250	22	50	3		SHXN0509F	TW15P HW35L	FTGA03512	ST32S
S32U-STFCR/L-16	40	32	30	350	22	50	3		SHXN0509F	TW15P HW35L	FTGA03512	ST32S
S40T-STFCR/L-16	50	40	37	300	27	60	3		SHXN0509F	TW15P	FTGA03512	ST32S
S40V-STFCR/L-16	50	40	37	400	27	60	3		SHXN0509F	TW15P HW35L		ST32S

STFPR/L

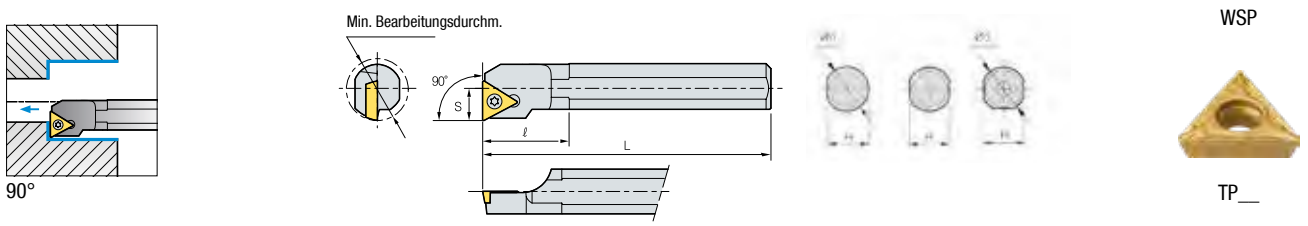

Bezeichnung	ØD	Ød	H	L	S	ℓ	Spannflächen	WSP	Schlüssel	Schraube
A10H-STFPR/L-11	12	10	9,5	100	6	30	1	TP__1103__	TW09P	FTNA0305
A12K-STFPR/L-11	16	12	11	125	8	30	1		TW09P	FTNA0307
A16M-STFPR/L-11	20	16	15	150	10	33	1		TW09P	FTNA0307
A20Q-STFPR/L-16	25	20	19	180	12,5	41	1	TP__1604__	TW15P	FTNA0408
S10M-STFPR/L-11	12	10	9	150	6	24	2	TP__1103__	TW09P	FTNA0306
S12M-STFPR/L-11	16	12	11	150	8	-	2		TW09P	FTNA0307
S16N-STFPR/L-11	20	16	15	160	10	-	2		TW09P	FTNA0307
S16R-STFPR/L-11	20	16	15	200	10	33	2		TW09P	FTNA0307
S20N-STFPR/L-16	25	20	18	160	12,5	32	2	TP__1604__	TW15P	FTNA0408
S20S-STFPR/L-16	25	20	18	250	12,5	32	2		TW15P	FTNA0408



STUBR/L

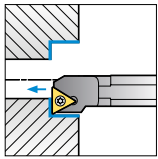

90°

Min. Bearbeitungsdurchm.

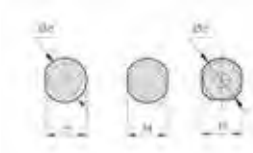
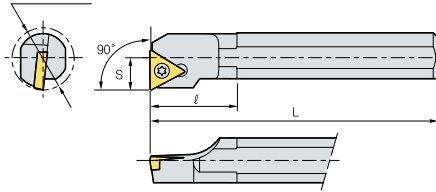

WSP



TB_

Bezeichnung	ØD	Ød	H	L	S	ℓ	Spannflächen	WSP	(mm)			
									Lagenschraube	Schlüssel	Schraube	Zwischenlage
A08F-STUBR/L-06	8	8	7,5	80	4	30	1	TB_0601_R/L	-	TW06P	FTNA0204	-
S08K-STUBR/L-06	8	8	7	125	4	30	2			TW06P	FTNA0204	

STUPR/L

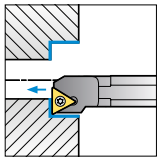

90°

Min. Bearbeitungsdurchm.

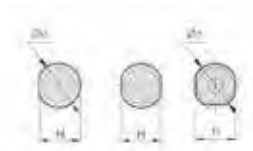
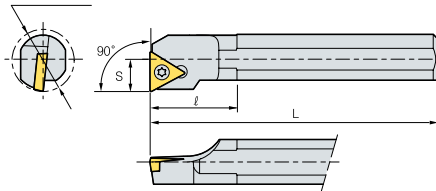

WSP



TP_

Bezeichnung	ØD	Ød	H	L	S	ℓ	Spannflächen	WSP	(mm)			
									Lagenschraube	Schlüssel	Schraube	Zwischenlage
A08F-STUPR/L-08	10	8	7,5	80	5	18	1	TP_0802_R/L	-	TW06P	FTNA02205	-
S08K-STUPR/L-08	10	8		125	5	18	2			TW06P	FTNA02205	



STWPR/L

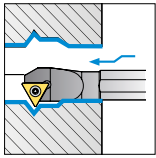

60°

Min. Bearbeitungsdurchm.

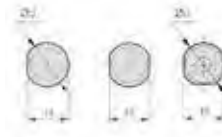
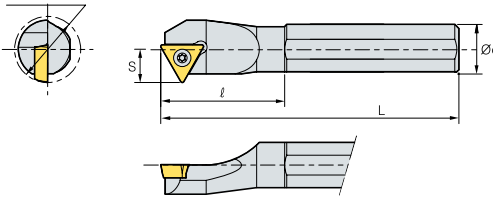

WSP



TP_

(mm)

Bezeichnung	ØD	Ød	H	L	S	ℓ	Spannflächen	WSP	Schlüssel	Schraube
S10M-STWPR/L-11	12	10	9	150	6	23	3	TP__1103_	TW09P	FTNA0305
S12M-STWPR/L-11	16	12	11	150	8	30	3		TW09P	FTNA0306
S16Q-STWPR/L-11	20	16	15	180	10	35	3		TW09P	FTNA0306
S16R-STWPR/L-11	20	16	15	180	10	35	3		TW09P	FTNA0306
S20R-STWPR/L-11	25	20	19	200	12,5	40	3		TW09P	FTNA0306

SVJCR/L

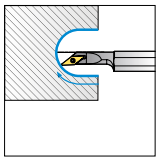

142°

Min. Bearbeitungsdurchm.

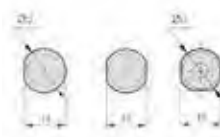
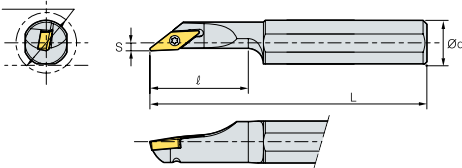

WSP



VCMT

(mm)

Bezeichnung	ØD	Ød	H	L	S	ℓ	Spannflächen	WSP	Schlüssel	Schraube
S12M-SVJCR/L-08	16	12	11	150	2	26	3	VCMT0802_	TW06P	FTNA0204
S16Q-SVJCR/L-08	20	16	15	180	2	36	3		TW06P	FTNA0204



SVQBR/L

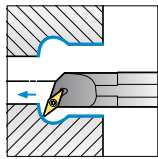

108°

Min. Bearbeitungsdurchm.

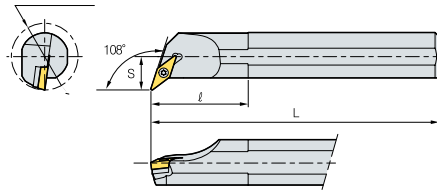

WSP



VB_

(mm)

Bezeichnung	ØD	Ød	H	L	S	ℓ	Spannflächen	WSP	Lagenschraube	Schlüssel	Schraube	Zwischenlage
A16R-SVQBR/L-11	20	16	15	200	11	27	1	VB__1102__	-	TW07P	FTKA02565	-
A32S-SVQBR/L-16	40	32	31	250	22	56	1	VB__1604__	SHXN0509F	TW15P HW35L	FTGA03512	SV32S
S32S-SVQBR/L-16	40	32	30	250	22	56	3		SHXN0509F	TW15P HW35L	FTGA03512	SV32S
S40T-SVQBR/L-16	50	40	37	300	27	64	3		SHXN0509F	TW15P HW35L	FTGA03512	SV32S
S40V-SVQBR/L-16	50	40	37	400	27	64	3		SHXN0509F	TW15P HW35L	FTGA03512	SV32S

SVQCR/L

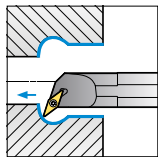

108°

Min. Bearbeitungsdurchm.

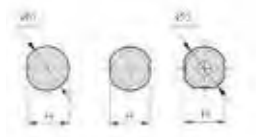
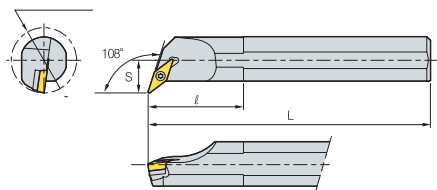

WSP



VC_

(mm)

Bezeichnung	ØD	Ød	H	L	S	ℓ	Spannflächen	WSP	Lagenschraube	Schlüssel	Schraube	Zwischenlage
A16M-SVQCR/L-11	16	12	11	125	8	30	1	VB__1102__	-	TW09P	FTNA0307	-
A20Q-SVQCR/L-11	25	20	18	180	13	35	1	VC__1303__	-	TW07P	FTKA02565	-
A20Q-SVQCR/L-13	25	20	18	180	13	42	3		-	TW09P	FTGA0307	-
A25R-SVQCR/L-11	32	25	23	200	17	35	3	VC__1103__	-	TW07P	FTKA02565	-
A25R-SVQCR/L-13	32	25	23	200	17	45	3	VC__1303__	-	TW09P	FTNA0307	-
A25R-SVQCR/L-16	32	25	23	200	17	40	3	VC__1604__	-	TW15P	FTGA03510	-
A32S-SVQCR/L-16	40	32	30	250	22	45	3	VC__1604__	SHXN0509F	TW15P HW35L	FTGA03512	SV32S
A40T-SVQCR/L-16	50	40	37	300	27	64	3		SHXN0509F	TW15P HW35L	FTGA03512	SV32S
S16R-SVQCR/L-11	20	16	15	200	11	35	3	VC__1103__	-	TW07P	FTKA02565	-
S20S-SVQCR/L-11	25	20	18	250	13	38	3	VC__1303__	-	TW07P	FTKA02565	-
S20S-SVQCR/L-13	25	20	18	250	13	42	3		-	TW09P	FTGA0307	-
S25R-SVQCR/L-11	32	25	23	200	17	35	3	VC__1103__	-	TW07P	FTKA02565	-
S25R-SVQCR/L-13	32	25	23	200	17	45	3	VC__1303__	-	TW09P	FTNA0307	-
S25R-SVQCR/L-16	32	25	23	200	17	40	3	VC__1604__	-	TW15P	FTGA03510	-
S25T-SVQCR/L-16	32	25	23	300	17	40	3	VC__1604__	-	TW15P HW35L	FTGA03510	-
S32S-SVQCR/L-16	40	32	30	250	22	45	3		SHXN0509F	TW15P HW35L	FTGA03512	SV32S
S32U-SVQCR/L-16	40	32	30	350	22	56	3	VC__1604__	SHXN0509F	TW15P HW35L	FTGA03512	SV32S
S40T-SVQCR/L-16	50	40	37	300	27	64	3		SHXN0509F	TW15P HW35L	FTGA03512	SV32S



SVUBR/L

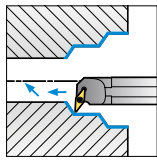

93°

Min. Bearbeitungsdurchm.

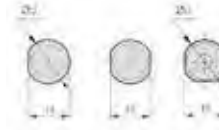
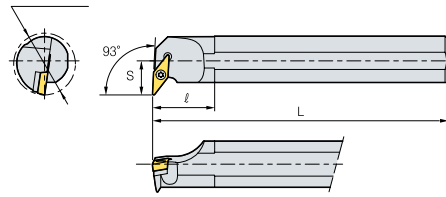

WSP



VB_

(mm)

Bezeichnung	ØD	Ød	H	L	S	ℓ	Spannflächen	WSP	Lagenschraube	Schlüssel	Schraube	Zwischenlage
A25T-SVUBR/L-11	32	25	23	300	17	30	1	VB_1102_	-	TW07P	FTKA02565	-
A32S-SVUBR/L-16	40	32	31	250	22	49	1	VB_1604_	SHXN0509F	TW15P HW35L	FTGA03512	SV32S
S25T-SVUBR/L-16	32	25	23	300	17	40	3		SHXN0509F	TW15P HW35L	FTGA03512	SV32S
S32S-SVUBR/L-16	40	32	30	250	22	40	3		SHXN0509F	TW15P HW35L	FTGA03512	SV32S
S32U-SVUBR/L-16	40	32	30	350	22	40	3		SHXN0509F	TW15P HW35L	FTGA03512	SV32S
S40T-SVUBR/L-16	50	40	37	300	27	50	3		SHXN0509F	TW15P HW35L	FTGA03512	SV32S
S40V-SVUBR/L-16	50	40	37	400	27	50	3		SHXN0509F	TW15P HW35L	FTGA03512	SV32S

SVUCR/L

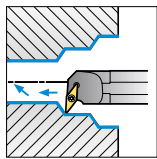

93°

Min. Bearbeitungsdurchm.

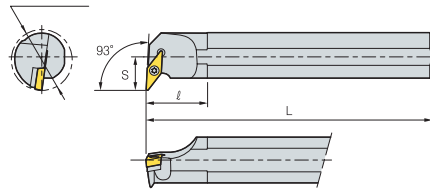

WSP



VC_

(mm)

Bezeichnung	ØD	Ød	H	L	S	ℓ	Spannflächen	WSP	Lagenschraube	Schlüssel	Schraube	Zwischenlage
A40T-SVUCR/L-16	50	40	37	300	27	43	1	VC_1604_	SHXN0509F	TW15P HW35L	FTGA03512	SV32S
S16R-SVUCR/L-11	22	16	15	200	13	30	3	VC_1103_	-	TW07P	FTKA02565	-
S20S-SVUCR/L-11	25	20	18	250	14	33	3		TW07P	FTKA02565	-	-
S20S-SVUCR/L-13	28	20	18	250	16	35	3	VC_1303_	-	TW09P	FTKA0307	-
S25R-SVUCR/L-13	32	25	23	200	17	40	3		TW09P	FTKA0307	-	-
S25R-SVUCR/L-16	32	25	23	200	19	50	3	VC_1604_	-	TW15P	FTGA03510	-
S25T-SVUCR/L-11	32	25	23	300	17	38	3	VC_1103_	-	TW07P	FTKA02565	-
S25T-SVUCR/L-16	32	25	23	300	19	50	3	VC_1604_	-	TW15P	FTGA03510	-
S32S-SVUCR/L-16	40	32	30	250	22	56	3		SHXN0509F	TW15P HW35L	FTGA03512	SV32S
S32U-SVUCR/L-16	40	32	30	350	22	56	3		SHXN0509F	TW15P HW35L	FTGA03512	SV32S
S40T-SVUCR/L-16	50	40	37	300	27	64	3		SHXN0509F	TW15P HW35L	FTGA03512	SV32S
S40V-SVUCR/L-16	50	40	37	400	27	64	3		SHXN0509F	TW15P HW35L	FTGA03512	SV32S



SWLCR/L

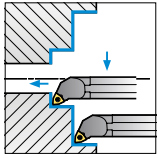

95°

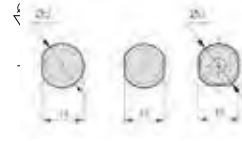
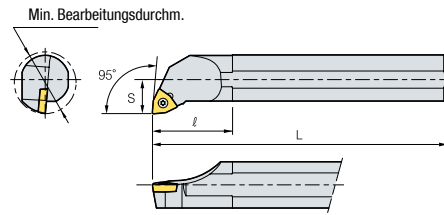

WSP



WC_

(mm)

Bezeichnung	ØD	Ød	H	L	S	ℓ	Spannflächen	WSP	Schlüssel	Schraube
A25R-SWLCR/L-08	32	25	24	200	17	46	1	WC_0804_	TW15P	FTGA0411F
S25R-SWLCR/L-08	32	25	23	200	17	46	3		TW15P	FTGA0411F
S25T-SWLCR/L-08	32	25	23	300	17	38	3		TW15P	FTGA0411F
A32S-SWLCR/L-08	40	32	31	250	22	51	1		TW15P	FTGA0411F
S32S-SWLCR/L-08	40	32	30	250	22	51	3		TW15P	FTGA0411F
S32U-SWLCR/L-08	40	32	30	350	22	51	3		TW15P	FTGA0411F



SCLCR/L

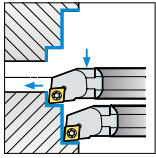

95°

Min. Bearbeitungsdurchm.

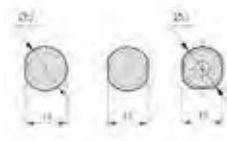
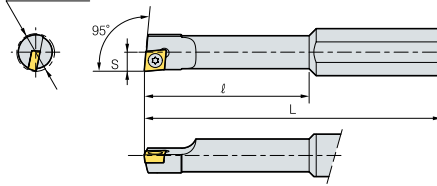

WSP



CCET

(mm)

Bezeichnung	ØD	Ød	H	L	S	ℓ	Spannflächen	WSP	Schlüssel	Schraube
S10H-SCLCR/L-0305	5	10	9	100	2,5	25	2	CCET0301_	TW06P	FTNA01633
S10H-SCLCR/L-0306	6	10	9	100	3	25	2		TW06P	FTNA01633
S10J-SCLCR/L-0407	7	10	9	110	3,5	30	2	CCET0401_	TW06P	FTNA0238
S10J-SCLCR/L-0408	8	10	9	110	4	30	2		TW06P	FTNA0238

STUBR/L

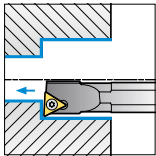

93°

Min. Bearbeitungsdurchm.

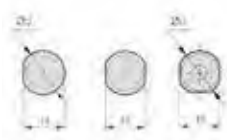
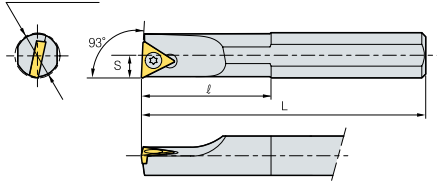

WSP



TB_

(mm)

Bezeichnung	ØD	Ød	H	L	S	ℓ	Spannflächen	WSP	Schlüssel	Schraube
A08F-STUBR/L-06	8	8	7,5	80	4	30	1	TB__0601__R/L	TW06P	FTNA0204
S08K-STUBR/L-06	8	8	7	125	4	30	2		TW06P	FTNA0204

• Halter entgegengesetzt zur Richtung der Schneidplatte



STUPR/L

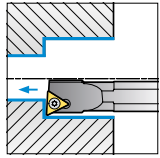

93°

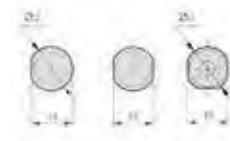
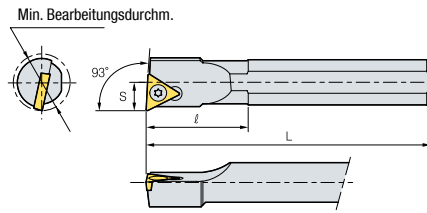

WSP



TP_

Bezeichnung	ØD	Ød	H	L	S	ℓ	Spannflächen	WSP	Schlüssel	Schraube
A08F-STUPR/L-08	10	8	7,5	80	5	18	1	TP_0802_R/L	TW06P	FTNA02205
S08K-STUPR/L-08	10	8	7	125	5	18	2		TW06P	FTNA02205

(mm)

SWUBR/L

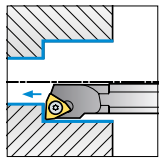

93°

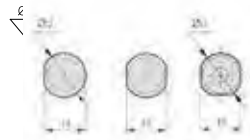
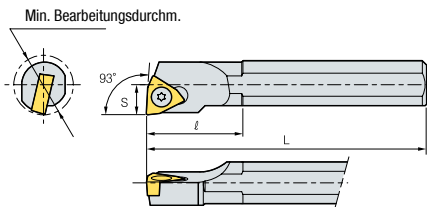

WSP



WBG

Bezeichnung	ØD	Ød	H	L	S	ℓ	Spannflächen	WSP	Schlüssel	Schraube
A08F-SWUBR/L-S3	10	8	7,5	80	5	16	1	WBGTS302_R/L	TW06P	FTNA02205
S08K-SWUBR/L-S3	10	8	7	125	5	16	3		TW06P	FTNA02205
S05H-SWUBR/L-02	5,5	5	4,5	100	2,75	-	2	WBG0201_R/L	TW06P	FTNA0203
A08F-SWUBR/L-02	8	8	7,5	80	4	30	1		TW06P	FTNA0203
S08K-SWUBR/L-02	8	8	7	125	4	30	2		TW06P	FTNA02033

(mm)

• Halter entgegengesetzt zur Richtung der Schneidplatte



SCLCR/L

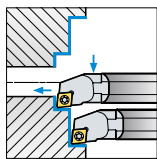

95°

Min. Bearbeitungsdurchm.

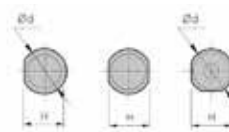
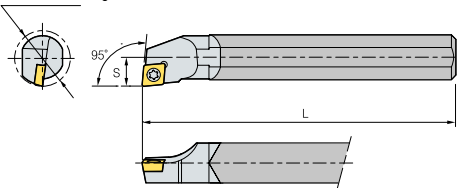

WSP



CC_

(mm)

Bezeichnung	ØD	Ød	H	L	S	Spannflächen	WSP	Schlüssel	Schraube
C08K-SCLCR/L-06	10	8	7	125	5	2	CC_T0602_	TW07P	FTKA02555
E08K-SCLCR/L-06	10	8	7	125	5	2		TW07P	FTKA02555
C10K-SCLCR/L-06	12	10	9	125	6	2		TW07P	FTKA02565
C10M-SCLCR/L-06	12	10	9	150	6	2		TW07P	FTKA02565
E10K-SCLCR/L-06	12	10	9	125	6	2		TW07P	FTKA02565
E10M-SCLCR/L-06	12	10	9	150	6	2		TW07P	FTKA02565
C12M-SCLCR/L-06	14	12	11	150	7	2		TW07P	FTKA02565
C12Q-SCLCR/L-06	14	12	11	180	7	2		TW07P	FTKA02565
E12M-SCLCR/L-06	14	12	11	150	7	2		TW07P	FTKA02565
E12Q-SCLCR/L-06	14	12	11	180	7	2		TW07P	FTKA02565
C12M-SCLCR/L-09	15	12	11	150	8	2	CC_T09T3_	TW15P	FTGA03508
C12Q-SCLCR/L-09	15	12	11	180	8	2		TW15P	FTGA03508
E12M-SCLCR/L-09	15	12	11	150	8	2		TW15P	FTGA03508
E12Q-SCLCR/L-09	15	12	11	180	8	2		TW15P	FTGA03508
C16R-SCLCR/L-09	20	16	15	200	10	2		TW15P	FTGA03508
C16S-SCLCR/L-09	20	16	15	250	10	2		TW15P	FTGA03508
E16R-SCLCR/L-09	20	16	15	250	10	2		TW15P	FTGA03508
E16S-SCLCR/L-09	20	16	15	250	10	2		TW15P	FTGA03508
C20R-SCLCR/L-09	25	20	18	200	13	2		TW15P	FTGA03508
C20S-SCLCR/L-09	25	20	18	250	13	2		TW15P	FTGA03508
E20R-SCLCR/L-09	25	20	18	200	13	2		TW15P	FTGA03508
E20S-SCLCR/L-09	25	20	18	250	13	2		TW15P	FTGA03508
C25T-SCLCR/L-12	32	25	23	300	17	2	CC_T1204_	TW15P	FTGA0411F
E25T-SCLCR/L-12	32	25	23	300	17	2		TW15P	FTGA0411F
C04G-SCLCR/L-03	5	4	3,8	90	2,5	1	CC_T0301_	TW06P	FTNA01633
C05H-SCLCR/L-03	6	5	4,4	100	3	1		TW06P	FTNA01633
C06H-SCLCR/L-04	7	6	5,4	100	3,5	1	CC_T0401_	TW06P	FTNA0238
E06H-SCLCR/L-04	7	6	5,4	100	3,5	1		TW06P	FTNA0238
C07K-SCLCR/L-04	8	7	6,4	125	4	1		TW06P	FTNA0238
E07K-SCLCR/L-04	8	7	6,4	125	4	1		TW06P	FTNA0238



SCLPR/L

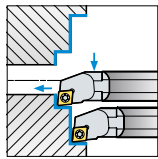

95°

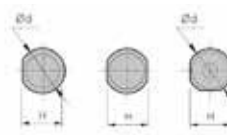
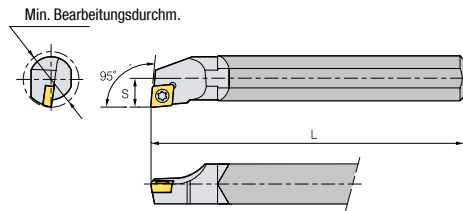

WSP



CP_

(mm)

Bezeichnung	ØD	Ød	H	L	S	Spannflächen	WSP	Schlüssel	Schraube
C10K-SCLPR/L-08	12	10	9	125	6	2	CP_T0802_	TW09P	FTNA0305
C10M-SCLPR/L-08	12	10	9	150	6	2	CP_T0802_	TW09P	FTNA0305
E10K-SCLPR/L-08	12	10	9	125	6	2		TW09P	FTNA0305
E10M-SCLPR/L-08	12	10	9	150	6	2		TW09P	FTNA0305
C12M-SCLPR/L-08	15	12	11	150	7,5	2		TW09P	FTNA0306
C12M-SCLPR/L-09	15	12	11	150	8	2	CP_T0903_	TW15P	FTNA0408
C12Q-SCLPR/L-08	15	12	11	180	7,5	2	CP_T0802_	TW09P	FTNA0306
C12Q-SCLPR/L-09	15	12	11	180	8	2	CP_T0903_	TW15P	FTNA0408
E12M-SCLPR/L-08	15	12	11	150	7,5	2	CP_T0802_	TW09P	FTNA0306
E12M-SCLPR/L-09	15	12	11	150	8	2	CP_T0903_	TW15P	FTNA0408
E12Q-SCLPR/L-08	15	12	11	180	7,5	2	CP_T0802_	TW09P	FTNA0305
E12Q-SCLPR/L-09	15	12	11	180	8	2	CP_T0903_	TW15P	FTNA0408
C16R-SCLPR/L-09	20	16	15	200	10	2	CP_T0802_	TW15P	FTNA0408
C16S-SCLPR/L-09	20	16	15	250	10	2		TW15P	FTNA0408
E16R-SCLPR/L-09	20	16	15	200	10	2		TW15P	FTNA0408
E16S-SCLPR/L-09	20	16	15	250	10	2		TW15P	FTNA0408
C20R-SCLPR/L-09	25	20	18	200	13	2	CP_T0802_	TW15P	FTNA0408
C20S-SCLPR/L-09	25	20	18	250	13	2		TW15P	FTNA0408
E20R-SCLPR/L-09	25	20	18	200	13	2		TW15P	FTNA0408
E20S-SCLPR/L-09	25	20	18	250	13	2		TW15P	FTNA0408



SDQCR/L

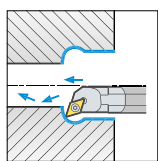

107,5°

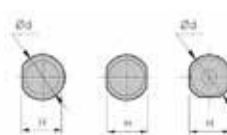
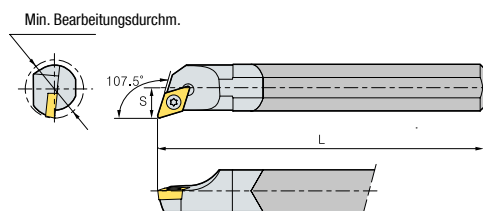

WSP

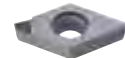

DC_

(mm)

Bezeichnung	ØD	Ød	H	L	S	Spannflächen	WSP	Schlüssel	Schraube
C08K-SDQCR/L-07	10	8	7	125	6	2	DC_T0702_	TW07P	FTKA02555
E08K-SDQCR/L-07	10	8	7	125	6	2		TW07P	FTKA02555
C10K-SDQCR/L-07	13	10	9	125	7	2		TW07P	FTKA02555
E10K-SDQCR/L-07	13	10	9	125	7	2		TW07P	FTKA02555
C12M-SDQCR/L-07	16	12	11	150	9	2		TW07P	FTKA02565
E12M-SDQCR/L-07	16	12	11	150	9	2		TW07P	FTKA02565
C16R-SDQCR/L-07	20	16	15	200	11	2		TW07P	FTKA02565
C16R-SDQCR/L-11	20	16	15	200	11	2	DC_T11T3_	TW15P	FTGA03508
E16R-SDQCR/L-07	20	16	15	200	11	2	DC_T0702_	TW07P	FTKA02565
E16R-SDQCR/L-11	20	16	15	200	11	2	DC_T11T3_	TW15P	FTGA03508
C20R-SDQCR/L-11	25	20	18	200	13	2		TW15P	FTGA03508
C20S-SDQCR/L-11	25	20	18	250	13	2		TW15P	FTGA03508
E20R-SDQCR/L-11	25	20	18	200	13	2		TW15P	FTGA03508
E20S-SDQCR/L-11	25	20	18	250	13	2		TW15P	FTGA03508



SDUCR/L

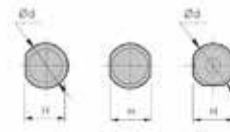
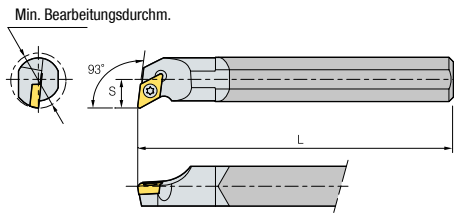
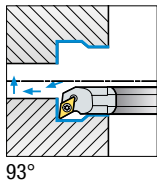

WSP

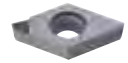

DC_

(mm)

Bezeichnung	ØD	Ød	H	L	S	Spannflächen	WSP	Schlüssel	Schraube
C10K-SDUCR/L-07	13	10	9	125	7	2	DC_T0702_	TW07P	FTKA02555
C10M-SDUCR/L-07	13	10	9	150	7	2		TW07P	FTKA02555
E10K-SDUCR/L-07	13	10	9	125	7	2		TW07P	FTKA02555
E10M-SDUCR/L-07	13	10	9	150	7	2		TW07P	FTKA02555
C12M-SDUCR/L-07	16	12	11	150	9	2		TW07P	FTKA02565
C12Q-SDUCR/L-07	16	12	11	180	9	2		TW07P	FTKA02565
E12M-SDUCR/L-07	16	12	11	150	9	2		TW07P	FTKA02565
E12Q-SDUCR/L-07	16	12	11	180	9	2		TW07P	FTKA02565
C16R-SDUCR/L-07	20	16	15	200	11	2		TW07P	FTKA02565
C16R-SDUCR/L-11	20	16	15	200	11	2		DC_T11T3_	TW15P
C16S-SDUCR/L-07	20	16	15	250	11	2	DC_T0702_	TW07P	FTKA02565
C16S-SDUCR/L-11	20	16	15	250	11	2	DC_T11T3_	TW15P	FTGA03508
E16R-SDUCR/L-07	20	16	15	200	11	2	DC_T0702_	TW07P	FTKA02565
E16R-SDUCR/L-11	20	16	15	200	11	2	DC_T11T3_	TW15P	FTGA03508
E16S-SDUCR/L-07	20	16	15	250	11	2	DC_T0702_	TW07P	FTKA02565
E16S-SDUCR/L-11	20	16	15	250	11	2	DC_T11T3_	TW15P	FTGA03508
C20R-SDUCR/L-11	25	20	18	200	13	2	DC_T11T3_	TW15P	FTGA03508
C20S-SDUCR/L-11	25	20	18	250	13	2		TW15P	FTGA03508
E20R-SDUCR/L-11	25	20	18	200	13	2		TW15P	FTGA03508
E20S-SDUCR/L-11	25	20	18	250	13	2		TW15P	FTGA03508
C25T-SDUCR/L-11	32	25	23	300	17	2		TW15P	FTGA03510
E25T-SDUCR/L-11	32	25	23	300	17	2		TW15P	FTGA03510



STFCR/L

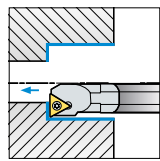

90°

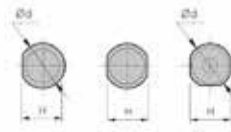
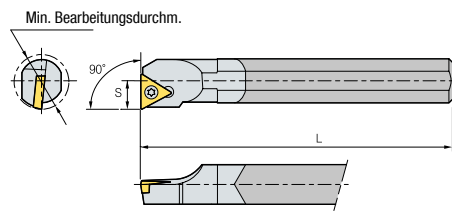

WSP



TC_

(mm)

Bezeichnung	ØD	Ød	H	L	S	Spannflächen	WSP	Schlüssel	Schraube
C08K-STFCR/L-09	10	8	7	125	5	2	TC_T0902_	TW06P	FTKA02206
E08K-STFCR/L-09	10	8	7	125	5	2		TW06P	FTKA02206
C10K-STFCR/L-09	12	10	9	125	6	2		TW06P	FTKA02206
C10K-STFCR/L-11	12	10	9	125	6	2	TC_T1102_	TW07P	FTKA02565
E10K-STFCR/L-09	12	10	9	125	6	2	TC_T0902_	TW06P	FTKA02206
E10K-STFCR/L-11	12	10	9	125	6	2	TC_T1102_	TW07P	FTKA02565
C12M-STFCR/L-11	15	12	11	150	8	2		TW07P	FTKA02565
E12M-STFCR/L-11	15	12	11	150	8	2		TW07P	FTKA02565
C16R-STFCR/L-11	20	16	15	200	10	2		TW07P	FTKA02565
E16R-STFCR/L-11	20	16	15	200	10	2		TW07P	FTKA02565
C20R-STFCR/L-11	25	20	18	200	13	2		TW07P	FTKA02565
C20R-STFCR/L-16	25	20	18	200	13	2	TC_T16T3_	TW15P	FTGA03510
C20S-STFCR/L-11	25	20	18	250	13	2	TC_T1102_	TW07P	FTKA02565
C20S-STFCR/L-16	25	20	18	250	13	2	TC_T16T3_	TW15P	FTGA03510
E20R-STFCR/L-11	25	20	18	200	13	2	TC_T1102_	TW07P	FTKA02565
E20R-STFCR/L-16	25	20	18	200	13	2	TC_T16T3_	TW15P	FTGA03510
E20S-STFCR/L-11	25	20	18	250	13	2	TC_T1102_	TW07P	FTKA02565
E20S-STFCR/L-16	25	20	18	250	13	2	TC_T16T3_	TW15P	FTGA03510



STFPR/L

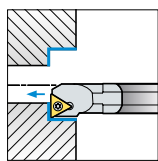

90°

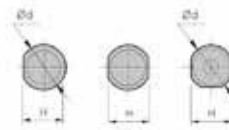
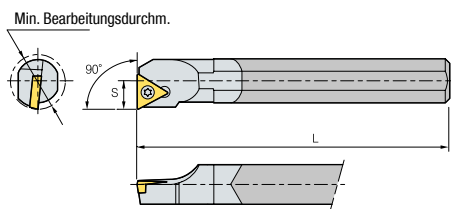

WSP



TP_

(mm)

Bezeichnung	ØD	Ød	H	L	S	Spannflächen	WSP	Schlüssel	Schraube
C08K-STFPR/L-08	10	8	7	125	5	2	TP_T0802_	TW06P	FTNA02205
E08K-STFPR/L-08	10	8	7	125	5	2		TW06P	FTNA02205
C10K-STFPR/L-11	12	10	9	125	6	2	TP_T1103_	TW09P	FTNA0305
C10M-STFPR/L-11	12	10	9	150	6	2		TW09P	FTNA0305
E10K-STFPR/L-11	12	10	9	125	6	2		TW09P	FTNA0305
E10M-STFPR/L-11	12	10	9	150	6	2		TW09P	FTNA0305
C12M-STFPR/L-11	15	12	11	150	8	2		TW09P	FTNA0307
C12Q-STFPR/L-11	15	12	11	180	8	2		TW09P	FTNA0307
E12M-STFPR/L-11	15	12	11	150	8	2		TW09P	FTNA0307
E12Q-STFPR/L-11	15	12	11	180	8	2		TW09P	FTNA0307
C16R-STFPR/L-11	20	16	15	200	10	2		TW09P	FTNA0307
C16S-STFPR/L-11	20	16	15	250	10	2		TW09P	FTNA0307
E16R-STFPR/L-11	20	16	15	200	10	2		TW09P	FTNA0307
E16S-STFPR/L-11	20	16	15	250	10	2		TW09P	FTNA0307
C20R-STFPR/L-11	25	20	18	200	13	2		TW09P	FTNA0307
C20R-STFPR/L-16	25	20	18	200	13	2	TP_T1604_	TW15P	FTNA0408
C20S-STFPR/L-11	25	20	18	250	13	2	TP_T1103_	TW09P	FTNA0307
C20S-STFPR/L-16	25	20	18	250	13	2	TP_T1604_	TW15P	FTNA0408
E20R-STFPR/L-11	25	20	18	200	13	3	TP_T1103_	TW09P	FTNA0307
E20R-STFPR/L-16	25	20	18	200	13	2	TP_T1604_	TW15P	FTNA0408
E20S-STFPR/L-11	25	20	18	250	13	2	TP_T1103_	TW09P	FTNA0307
E20S-STFPR/L-16	25	20	18	250	13	2	TP_T1604_	TW15P	FTNA0408
C25T-STFPR/L-16	32	25	23	300	17	2		TW15P	FTNA0408
E25T-STFPR/L-16	32	25	23	300	17	2		TW15P	FTNA0408



STUBR/L

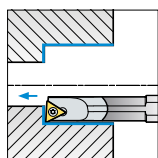

93°

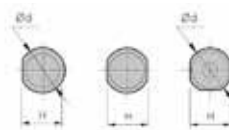
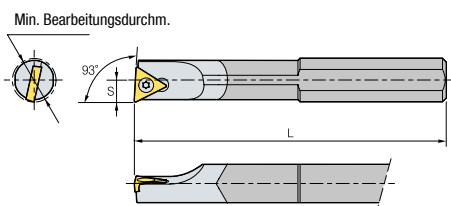

WSP



TB_

(mm)

Bezeichnung	ØD	Ød	H	L	S	Spannflächen	WSP	Schlüssel	Schraube
C06H-STUBR/L-06	8	6	5	100	4	1	TB_T0601_	TW06P	FTNA0204
C08K-STUBR/L-06	10	8	7	125	5	2		TW06P	FTNA0204
E08K-STUBR/L-06	10	8	7	125	5	2		TW06P	FTNA0204
C10K-STUBR/L-06	12	10	9	125	6	2		TW06P	FTNA0204
E10K-STUBR/L-06	12	10	9	125	6	2		TW06P	FTNA0204



STUPR/L

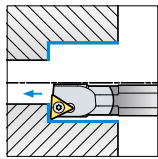

93°

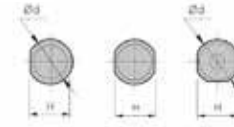
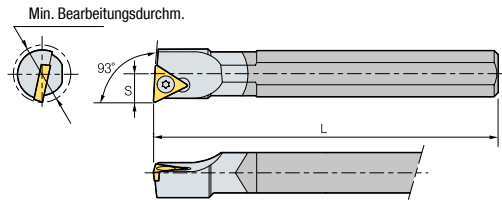

WSP



TP_

(mm)

Bezeichnung	ØD	Ød	H	L	S	Spannflächen	WSP	Schlüssel	Schraube
C08K-STUPR/L-08	10	8	7	125	5	2	TP_T0802_	TW06P	FTNA02205
E08K-STUPR/L-08	10	8	7	125	5	2		TW06P	FTNA02205
C10K-STUPR/L-11	12	10	9	125	6	2	TP_T1103_	TW09P	FTKA0305
C10M-STUPR/L-11	12	10	9	150	6	2		TW09P	FTKA0305
E10K-STUPR/L-11	12	10	9	125	6	2		TW09P	FTKA0305
E10M-STUPR/L-11	12	10	9	150	6	2		TW09P	FTKA0305
C12M-STUPR/L-11	15	12	11	150	8	2		TW09P	FTNA0307
C12Q-STUPR/L-11	15	12	11	180	8	2		TW09P	FTNA0307
E12M-STUPR/L-11	15	12	11	150	8	2		TW09P	FTNA0307
E12Q-STUPR/L-11	15	12	11	180	8	2		TW09P	FTNA0307
C16R-STUPR/L-11	20	16	15	200	10	2		TW09P	FTNA0307
C16S-STUPR/L-11	20	16	15	250	10	2		TW09P	FTNA0307
E16R-STUPR/L-11	20	16	15	200	10	2		TW09P	FTNA0307
E16S-STUPR/L-11	20	16	15	250	10	2		TW09P	FTNA0307
C20R-STUPR/L-11	25	20	18	200	13	2		TW09P	FTNA0307
C20R-STUPR/L-16	25	20	18	200	13	2	TP_T1604_	TW15P	FTNA0408
C20S-STUPR/L-11	25	20	18	250	13	2	TP_T1103_	TW09P	FTNA0307
C20S-STUPR/L-16	25	20	18	250	13	2	TP_T1604_	TW15P	FTNA0408
E20R-STUPR/L-11	25	20	18	200	13	2	TP_T1103_	TW09P	FTNA0307
E20R-STUPR/L-16	25	20	18	200	13	2	TP_T1604_	TW15P	FTNA0408
E20S-STUPR/L-11	25	20	18	250	13	2	TP_T1103_	TW09P	FTNA0307
E20S-STUPR/L-16	25	20	18	250	13	2	TP_T1604_	TW15P	FTNA0408
C25T-STUPR/L-16	32	25	23	300	17	2		TW15P	FTNA0408
E25T-STUPR/L-16	32	25	23	300	17	2		TW15P	FTNA0408



SWUBR/L

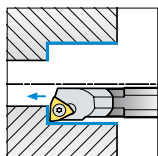

93°

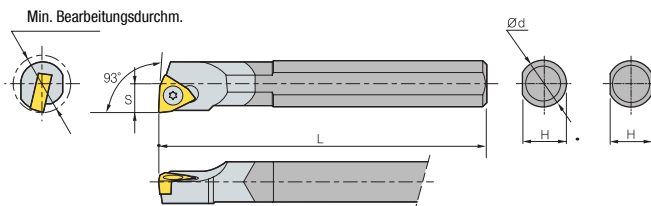

WSP



WB_T

(mm)

Bezeichnung	ØD	Ød	H	L	S	Spannflächen	WSP	Schlüssel	Schraube
C08K-SWUBR/L-S3	10	8	7	125	4,5	2	WB_TS302_	TW06P	FTNA02205
E08K-SWUBR/L-S3	10	8	7	125	5	2		TW06P	FTNA02205
C05H-SWUBR/L-02	6	5	4,4	100	3	1	WB_T0201_	TW06P	FTNA0203
C06H-SWUBR/L-02	7	6	5,4	100	3,5	1		TW06P	FTNA0203
E06H-SWUBR/L-02	7	6	5,4	100	3,5	-		TW06P	FTNA0203
C08K-SWUBR/L-02	9	8	7	125	4,5	2		TW06P	FTNA02033
E08K-SWUBR/L-02	9	8	7	125	4,5	2		TW06P	FTNA02033



Notizen

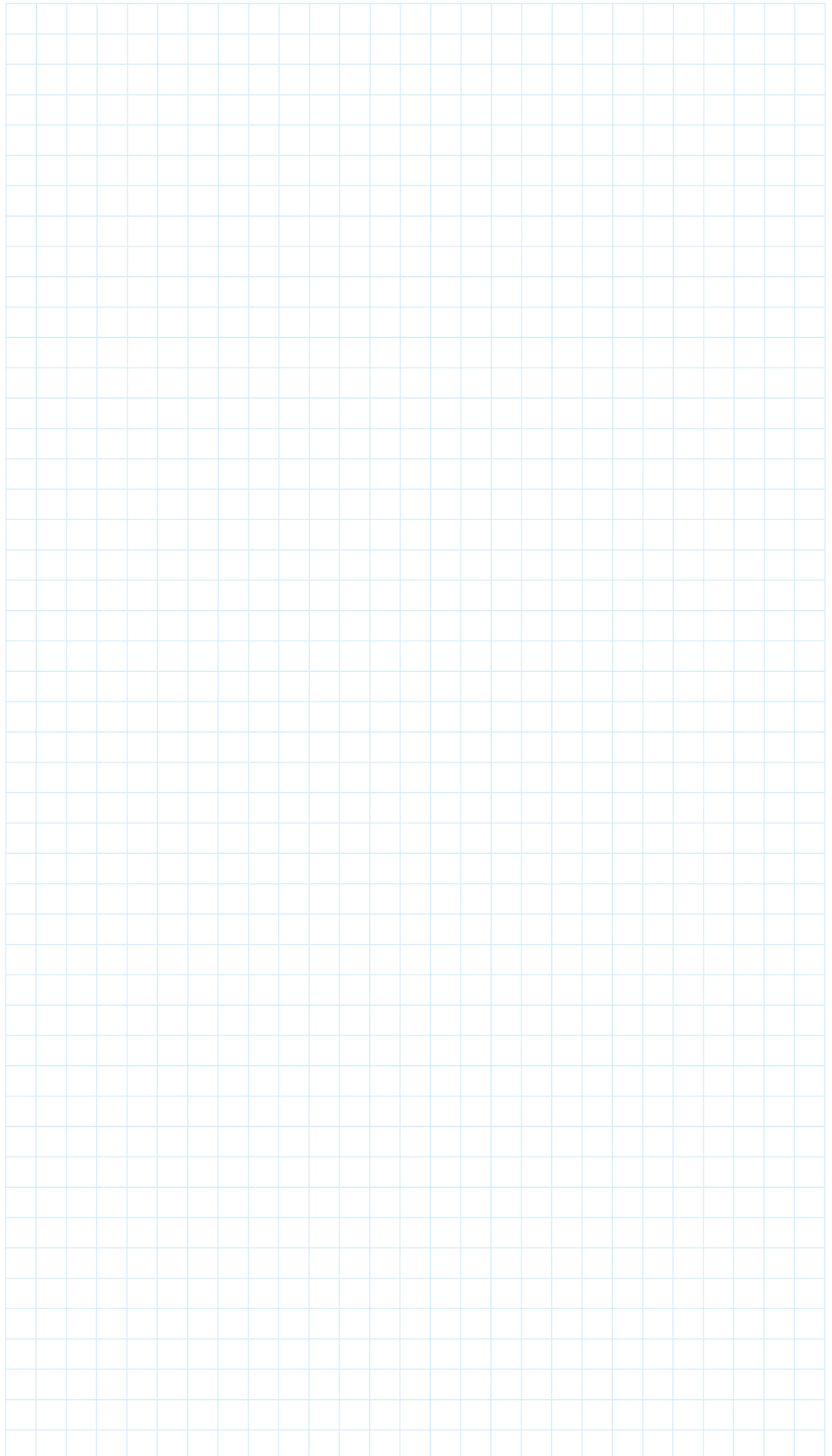

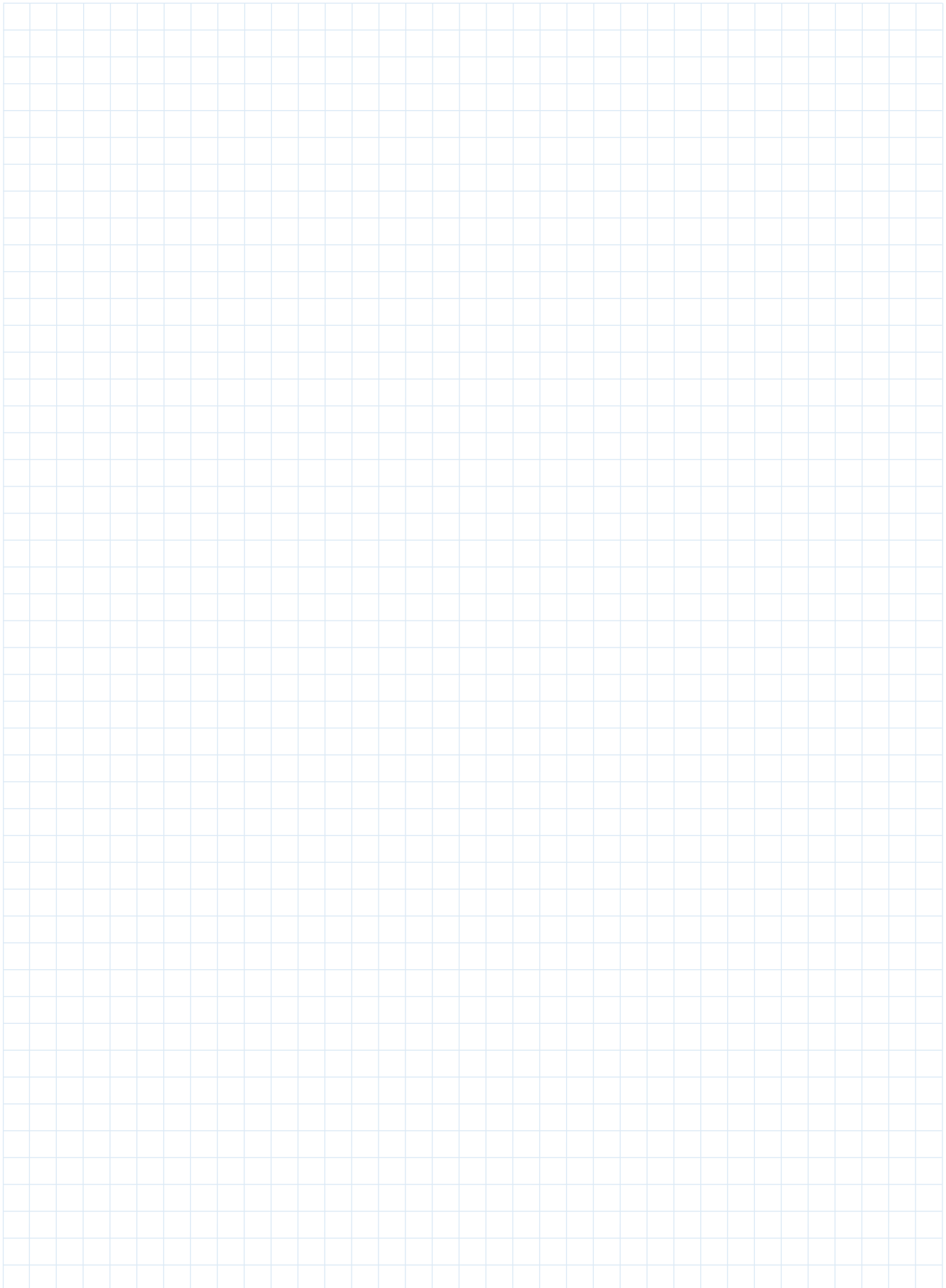



Notizen

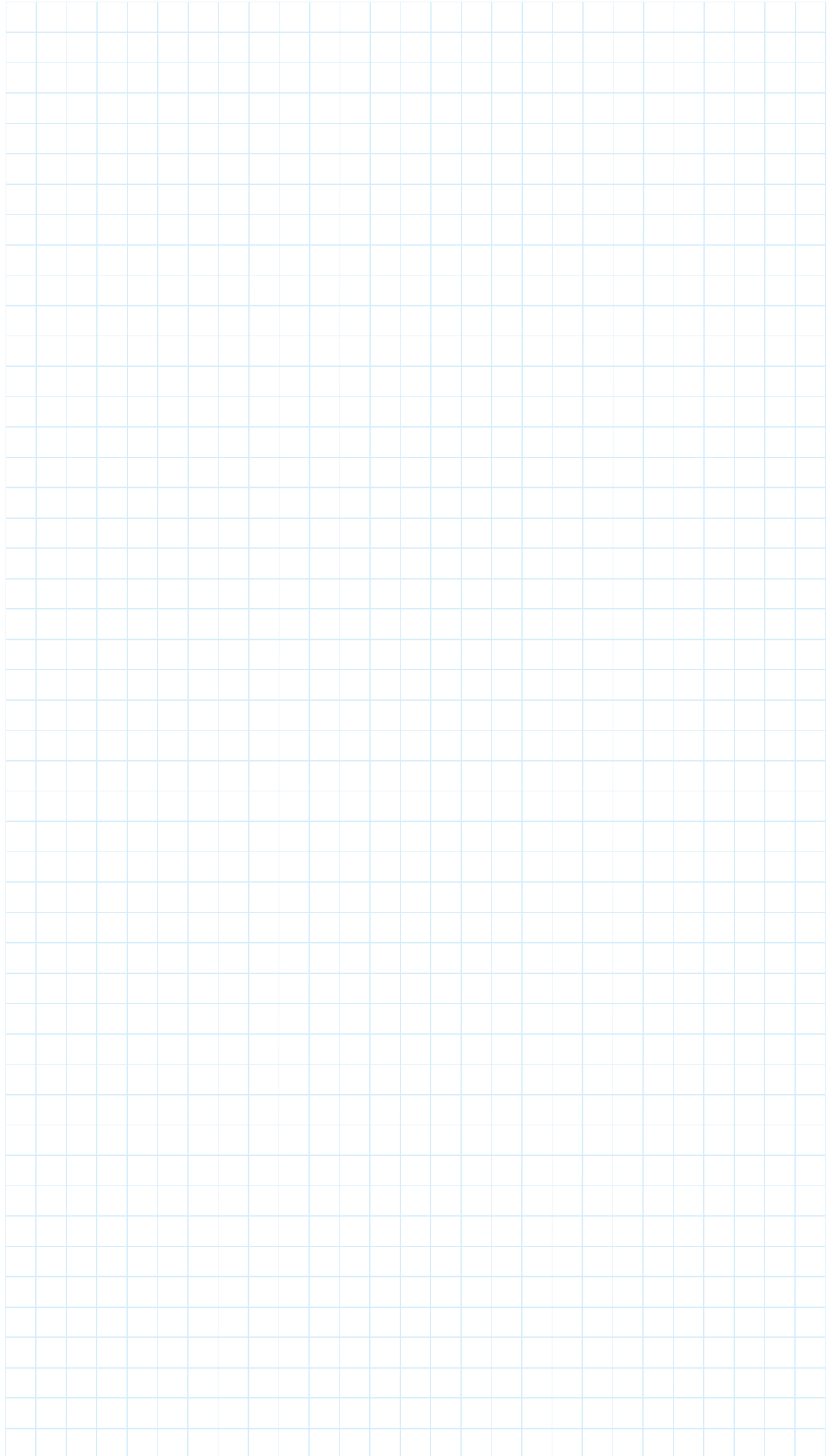

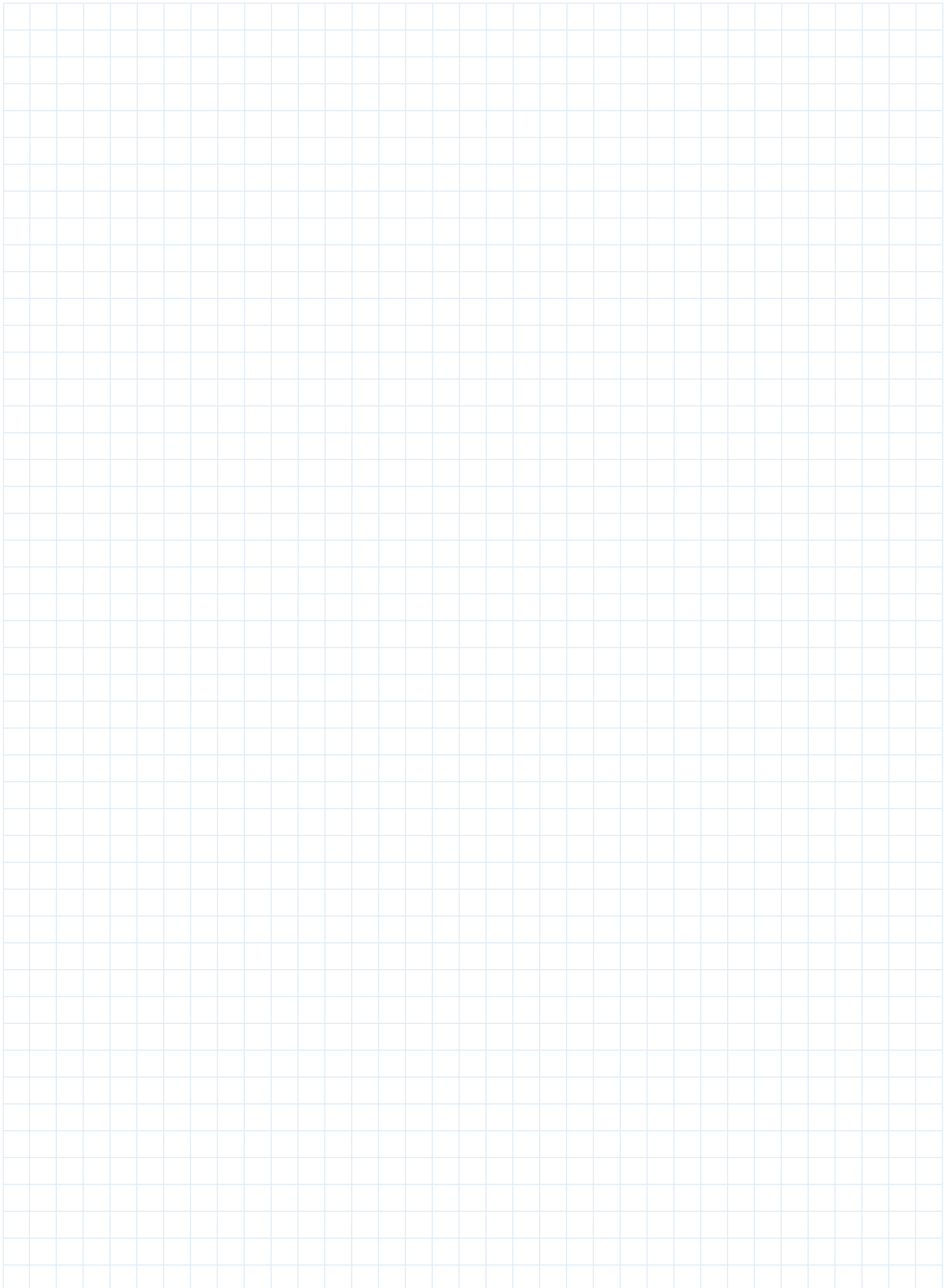

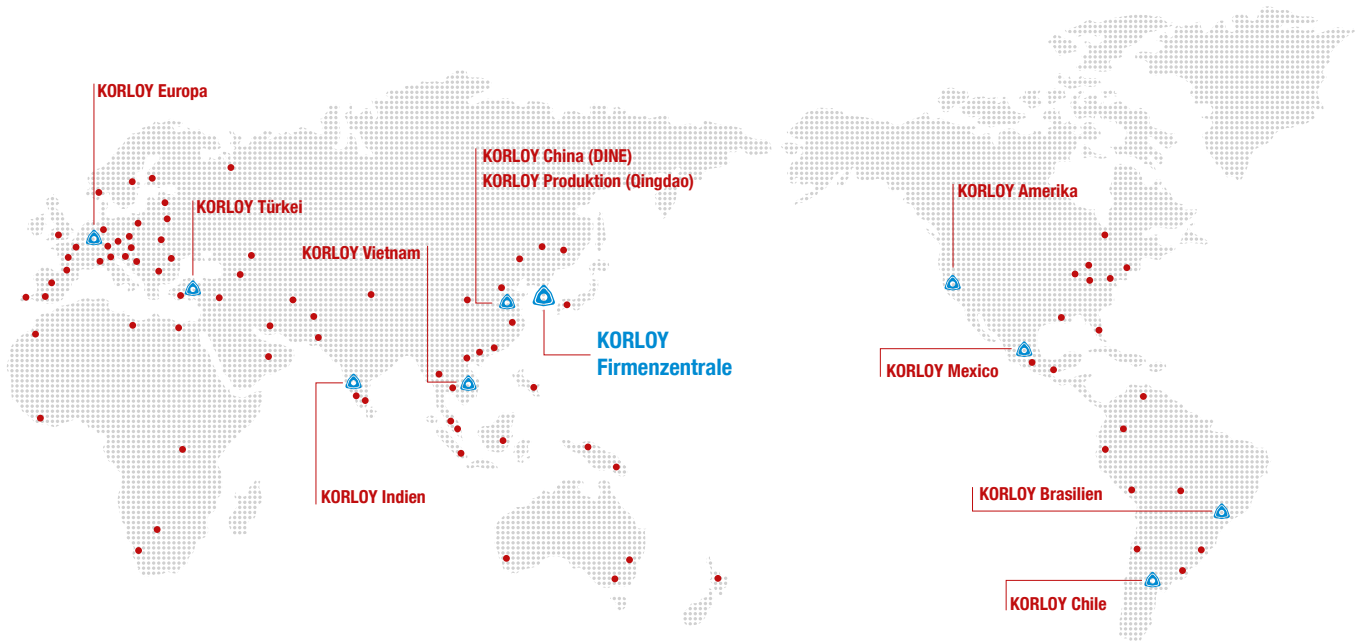

KORLOY

Firmenzentrale

Holystar B/D, 326, Seocho-daero, Seocho-gu, Seoul, 06633, Korea,
Web: www.korloy.com

Cheongju Produktion

55, Sandan-ro, Heungdeok-gu, Cheongju-si,
Chungcheongbuk-do, 28589, Korea

Jincheon Produktion

54, Gwanghyewonsandan 2-gil, Gwanghyewon-myeon,
Jincheon-gun, Chungcheongbuk-do, 27807, Korea

Seoul Forschung & Entwicklung

Holystar B/D, 326, Seocho-daero, Seocho-gu, Seoul, 06633, Korea

Cheongju Forschung & Entwicklung

55, Sandan-ro, Heungdeok-gu, Cheongju-si,
Chungcheongbuk-do, 28589, Korea

Gurgaon Produktion

Plot NO.415, Sector 8, IMT Manesar, Gurgaon 122051, Haryana, Indien

KORLOY EUROPE

Gablonzter Straße 25-27 · D-61440 Oberursel · Tel. +49-6171-27783-0 · Fax +49-6171-27783-59 · E-Mail: info@korloyeurope.com · Web: www.korloyeurope.eu

KORLOY AMERICA

620, Maple Avenue, Torrance, CA 90503, USA

KORLOY BRASIL

Av. Aruana 280, conj.12, WLC, Alphaville, Barueri, CEP06460-010, SP, Brasilien

KORLOY CHILE

Av. Providencia 1650, Office 1009, 7500027 Providencia-Santiago, Chile

KORLOY INDIA

Ground Floor, Property No. 217, Udyog Vihar Phase 4, Gurgaon 122016, Haryana, Indien

KORLOY TÜRKEI

Serifali Mahallesi, Burhan Sokak NO: 34 Dudullu OSB/Umraniye/Istanbul, 34775, Türkei

KORLOY VIETNAM

No. 133 Le Loi street, Hoa Phu ward, Thu Dau Mot city, Binh Duong proviende, Vietnam

KORLOY MEXICO

Calle R. M. Clemencia Borja Taboada 522, Jurica Acueducto, 76230 Juriquilla, Qro. Mexico

KTS - Korloy Tooling Solution



Gratis-APP im Store

Einfach kostenlos herunterladen,
installieren und verwenden.

20230508

Turning-02-de